

J. D. SLATE.
Breech-Loading Fire-Arms.

No. 204,768.

Patented June 11, 1878.

Fig. 1.

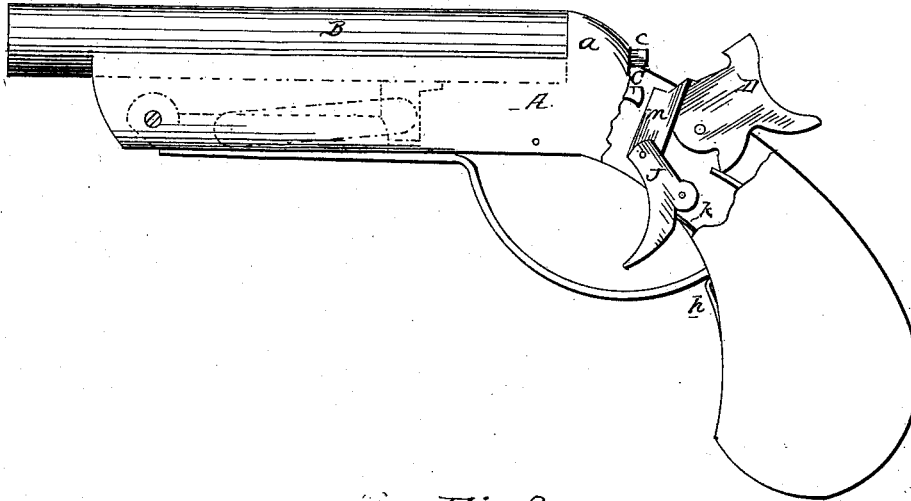

Fig. 2.

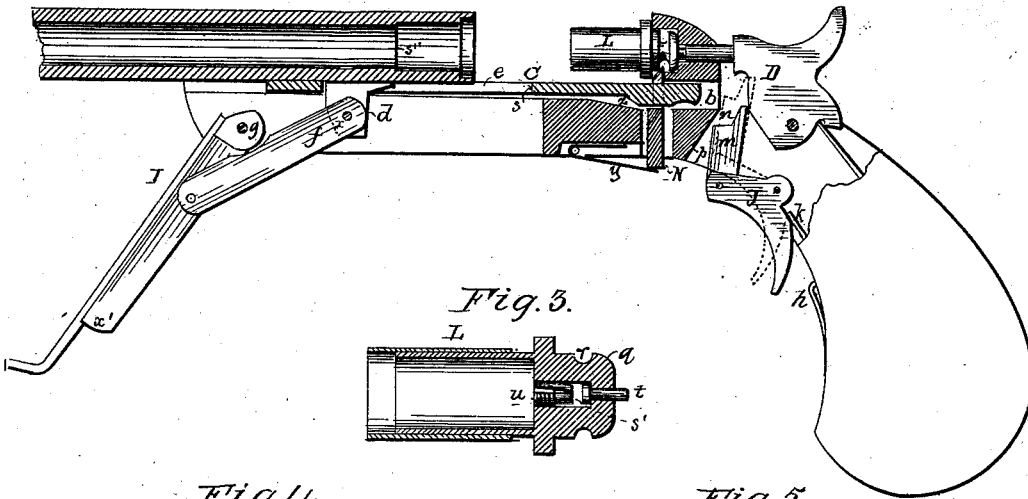

Fig. 3.

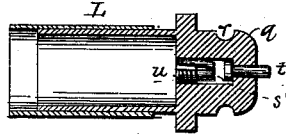
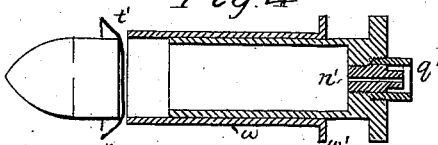

Fig. 4.



Attest:

Fred Benjamin.
George Show.

Fig. 5.

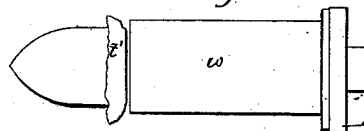

Inventor

J. D. Slate
By his attorney
Charles W. Foster

Passed Dec 5, 77.

UNITED STATES PATENT OFFICE.

JOHN D. SLATE, OF BERNARDSTON, MASSACHUSETTS.

IMPROVEMENT IN BREECH-LOADING FIRE-ARMS.

Specification forming part of Letters Patent No. **204,768**, dated June 11, 1878; application filed October 5, 1877.

To all whom it may concern:

Be it known that I, JOHN D. SLATE, of Bernardston, Franklin county, Massachusetts, have invented Improvements in Fire-Arms, of which the following is a specification:

My invention relates to that class of breech-loaders in which the barrel slides longitudinally; and my invention consists in certain devices for readily sliding the barrel, holding it firmly against the breech for retaining and releasing the cartridge, and for operating the hammer.

My invention further consists in constructing the cartridge so as to facilitate the loading of the same and the explosion of the charge and the patching of the ball.

In the accompanying drawing, Figure 1 is an external view, partly in section, of my improved fire-arm. Fig. 2 is a longitudinal section, showing the parts in another position. Fig. 3 is an enlarged sectional view of the cartridge, and Figs. 4 and 5 are modifications.

The stock or frame A carries the stationary breech *a*, in which slides the pin *c*, and is provided with guides, between which slides the barrel B. The stock below the barrel is recessed to receive a slide, C, the rear end of which extends through a slot, *b*, in the breech opposite the hammer D.

A lug, *d*, passes through a slot, *e*, in the slide C, and to this lug is jointed an arm, *f*, connected to a lever, I, jointed at its upper forward end by a pin, *g*, to the forward end of the frame.

The fulcrum of the arm and lever are so arranged that the forward movement of the lever will advance the barrel, while the rear motion of the lever will carry the barrel back against the breech, when the arm *f* will be so nearly parallel to the lever that the barrel will be locked in its place without any other fastening than a spring, *h*, or equivalent device for holding up the end of the lever, which is bent, as shown, to constitute the trigger-guard.

In order to insure the close contact of the rear end of the barrel and the breech, and to take the strain off the connecting-pins of the arm *f*, the lever is provided with an inclined shoulder, *x'*, which bears against the inclined side *x* of the lug *d* and forces the barrel back

closely against the breech. (See dotted lines, Fig. 1.)

The trigger J carries a block, *m*, having a notch, *n*, at its upper end, and sliding between a cross-piece, *p*, of the frame and the front edge of the hammer.

When the barrel is moved back the lug *d*, striking the end *s* of the slot *e* in the slide C, will carry the latter with it until the end of the slide strikes the block *m*, when the latter and the hammer D will be forced back to the position shown in Fig. 1.

When the trigger is pulled the block *m* will be drawn down until its notch *n* is brought opposite the end of the slide C, when the hammer will be released and fall against the pin *c*.

On drawing the barrel and slide forward and inserting another cartridge, after cocking the hammer, the spring *k*, bearing on the trigger, will carry the parts to the position shown in dotted lines, Fig. 2, preventing the hammer from exploding the charge.

The metallic cartridge L has a head, *q*, with an annular recess, *r*, and a chamber, *s'*, receiving the forward head of the sliding plunger *t*, and at the front end is a slotted screw-block, *u*, which constitutes the anvil, and between which and the plunger *t* the fulminate is exploded when the pin *c* drives the plunger forward.

Instead of using the plunger, the cartridge may have a hollow nipple, *n'*, adapted to receive an ordinary cap, and a sleeve, *q'*, screwing into the head and inclosing the nipple.

The cap may be removed after being exploded by a suitable implement, and if it becomes wedged in place the sleeve *q'* may be unscrewed and the cap withdrawn.

The cartridge is provided with a sliding shell, *w*, which is drawn forward to receive the head of the bullet inserted with a patch, *t'*, and is then pushed back by a shoulder, *s''*, in the barrel as the cartridge is inserted, thereby introducing the patched bullet into the barrel, the powder pushing the bullet above the shoulder and beyond the inner shell. The shell may be provided with a flange, *w'*, which strikes the end of the barrel, and serves as a means to extract the sliding shell with the other.

In order to prevent the cartridge and its shell

from being drawn forward with the barrel, I employ a vertical sliding catch, N, which is forced upward by a spring, *y*, and the upper end of which enters into the groove *r* in the head of the cartridge, or catches the flange *w'* or the rim or flange when an ordinary cartridge is used.

The catch N is depressed as the slide C is carried forward by the lug *d* striking the forward end of the slot *e*, an inclined shoulder, *z*, on the slide, forcing the catch downward.

As thus constructed the barrel B is readily moved and securely locked, the hammer is cocked by the movement of the barrel, the cartridge is withdrawn from the barrel and then released, and is readily charged and exploded, and the ball is packed and leading prevented.

I have shown the cartridge to illustrate the mode in which the arm may be employed in connection therewith; but I do not here claim the same.

I claim—

1. The combination, in a fire-arm, of a barrel, lever I, arm *f*, and lug *d*, having an inclined edge adapted to an inclined shoulder of the lever, substantially as specified.

2. The combination of the sliding barrel and the slides C, constructed and arranged to be carried with the barrel during a part of its movement, and to force back the hammer when moved to the rear, as set forth.

3. The combination of the hammer, the slide C, and the trigger J, carrying the block *m*, as set forth.

4. The catch N, in combination with the slide C, moving with the barrel, and provided with an inclined shoulder, as set forth.

In testimony whereof I have signed my name to this specification in the presence of two subscribing witnesses.

JOHN D. SLATE.

Witnesses:

S. J. GREEN,
H. P. GREEN.