

W. SPALCKHAVER.
Paper-Folding Machine.
No. 204,772. Patented June 11, 1878.

Fig. 1

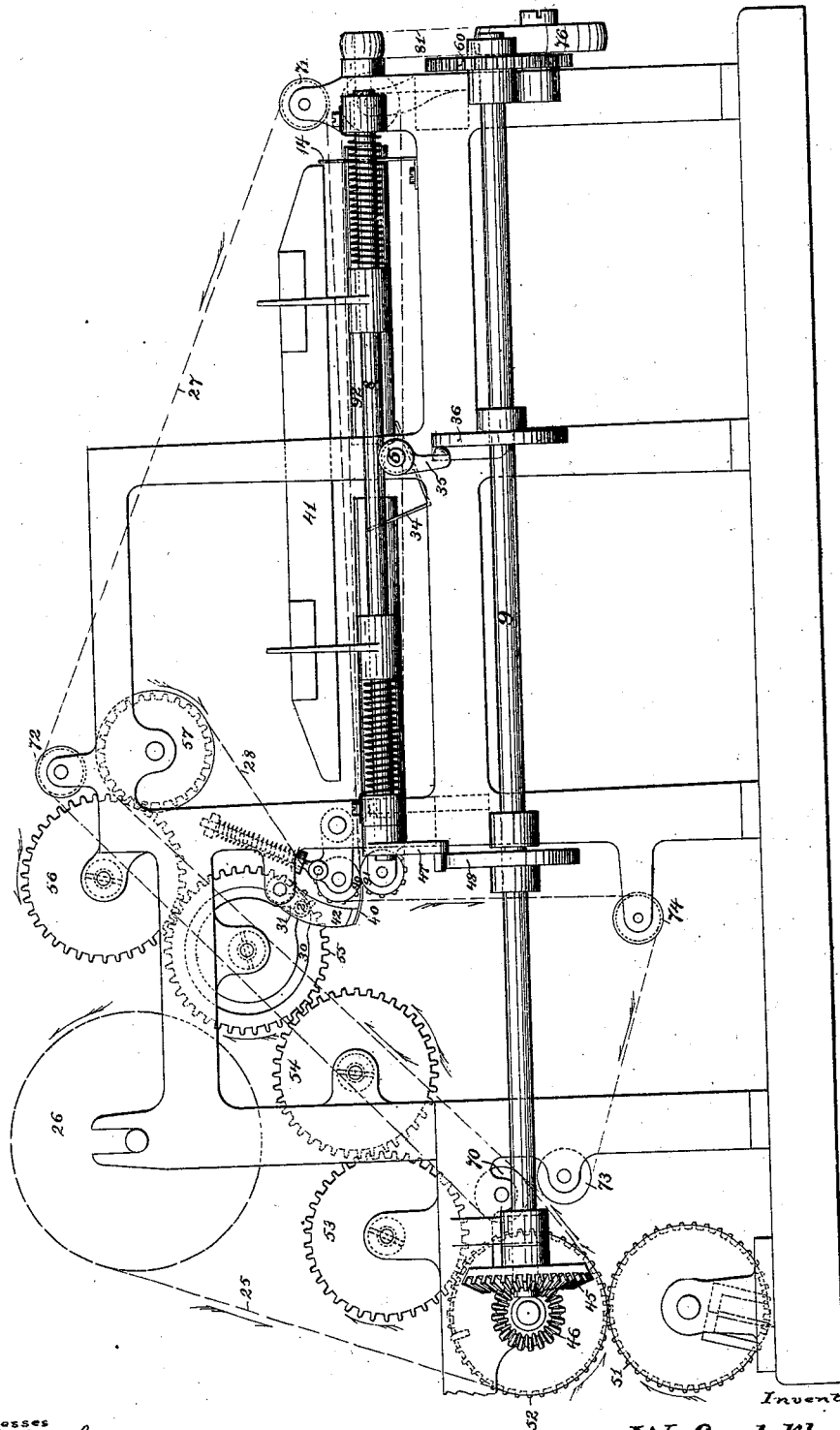

Witnesses
Geo. H. Graham.
Wm. C. Hespe

Inventor
W. Spalckhaver.
By Munson & Phillips
Attorneys

W. SPALCKHAVER.
Paper-Folding Machine.
No. 204,772. Patented June 11, 1878.

Fig. 2.

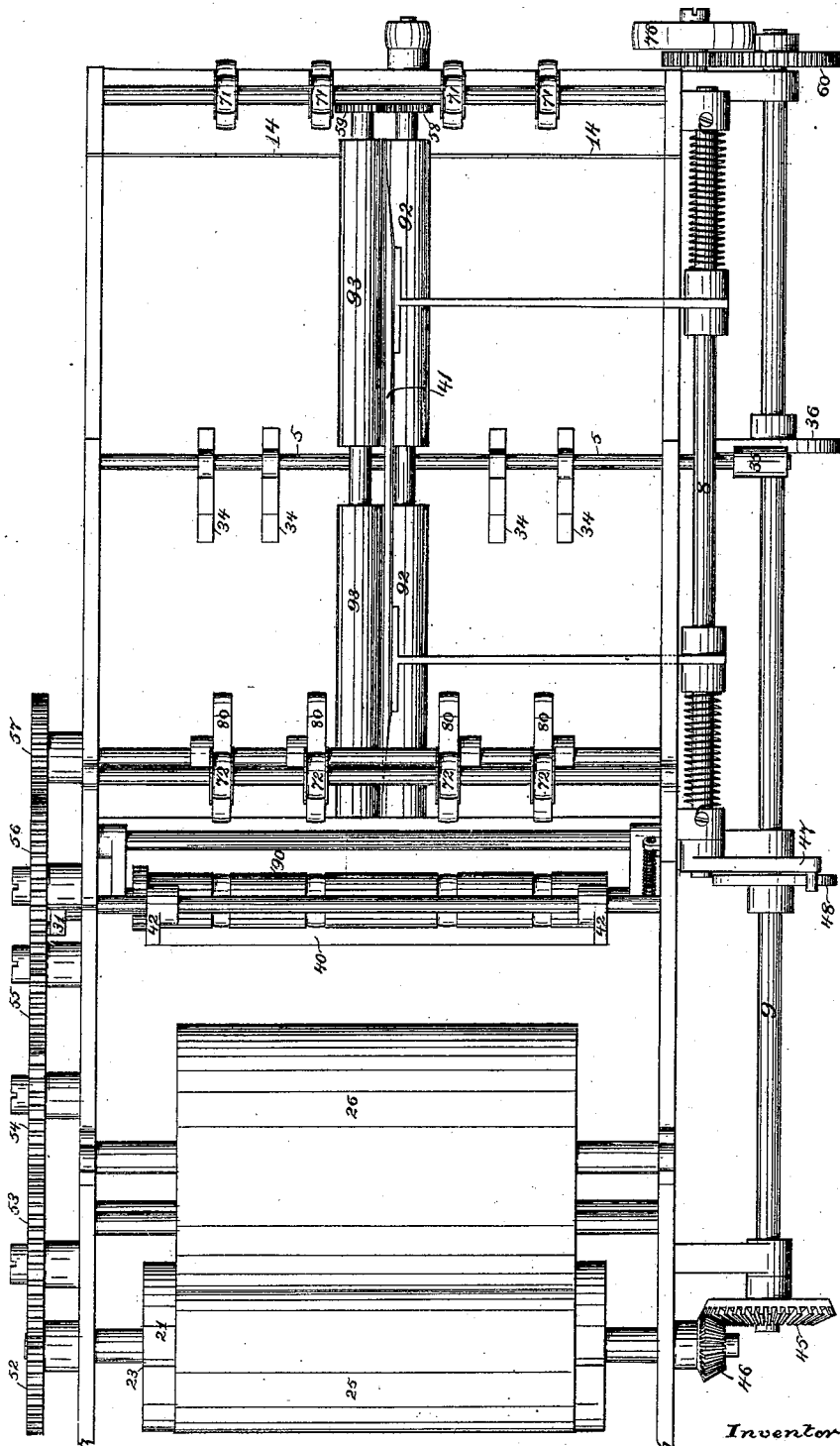

Witnesses:
C. B. Graham.
Wm. C. Kesper

Inventor

W. Spalckhaver
By Munson & Philipp,
Attorneys

W. SPALCKHAVER.
Paper-Folding Machine.
No. 204,772. Patented June 11, 1878.

Fig. 10.

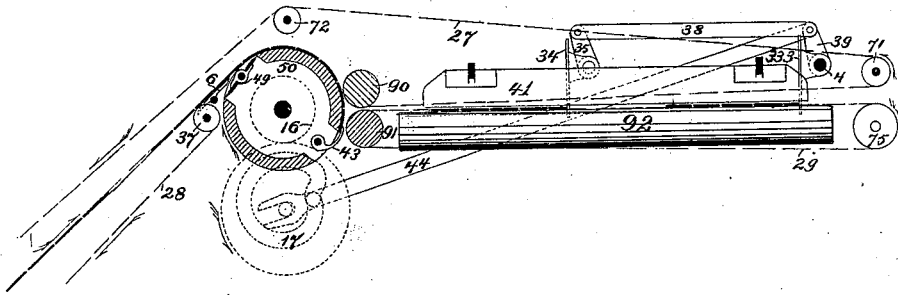
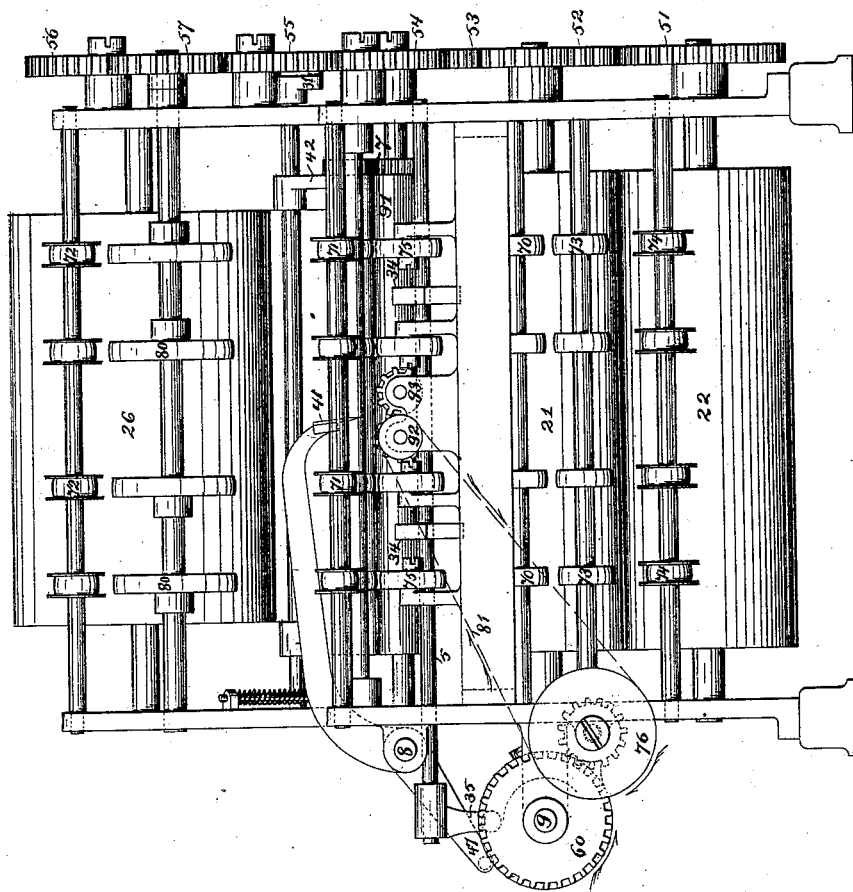

Fig. 3.



Witnesses
Geo. H. Galami.
Am. C. Klespe.

Inventor
W. Spalckhaver
By Munson & Philipp
Attorneys

W. SPALCKHAVER.
Paper-Folding Machine.
No. 204,772. Patented June 11, 1878.

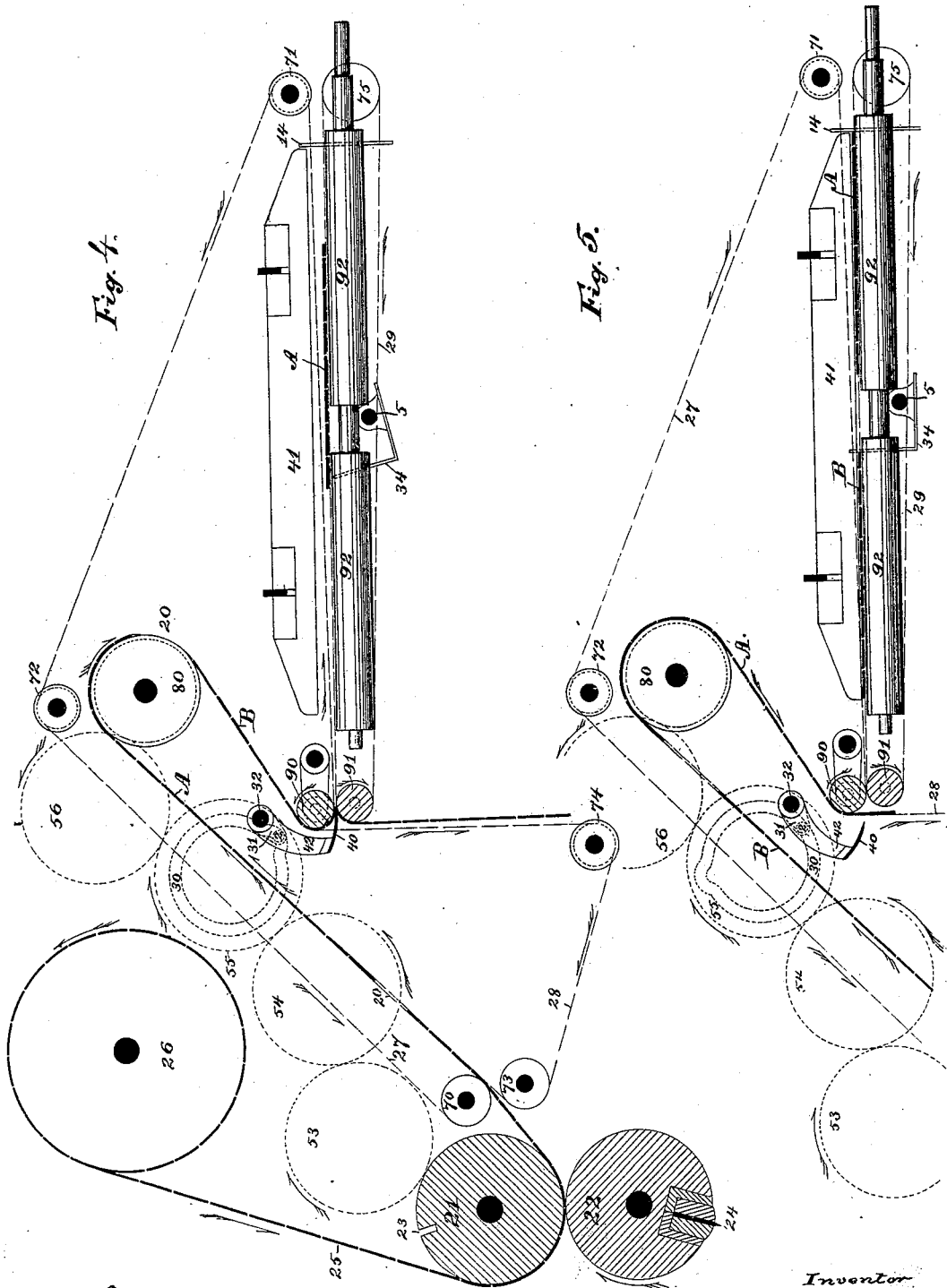

Fig. 4.

Fig. 5.

Witnesses
Geo. H. Graham.
Wm. C. Heape

Inventor
W. Spalckhaver
By *Mason & Cluff*
Attorneys

W. SPALCKHAVER.
Paper-Folding Machine.
No. 204,772. Patented June 11, 1878.

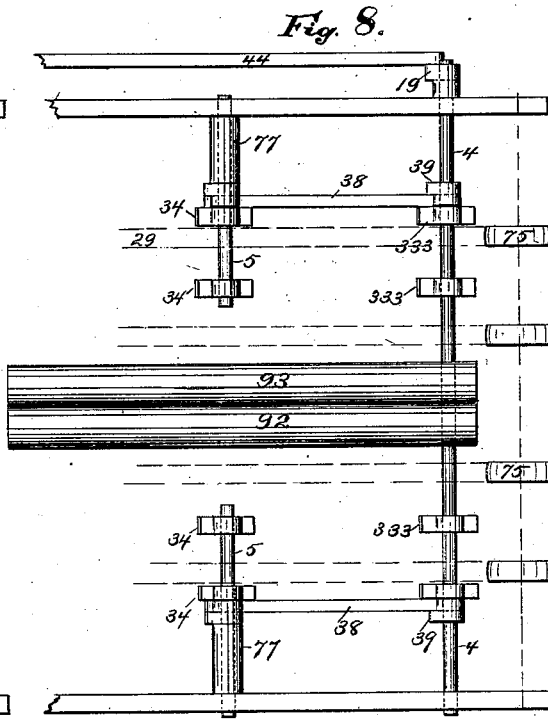
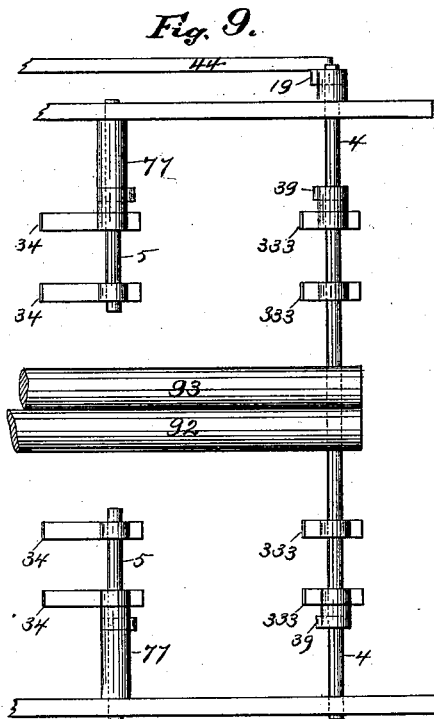
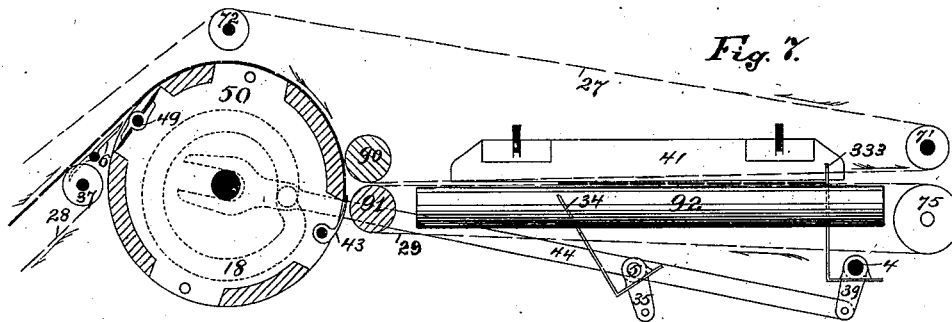
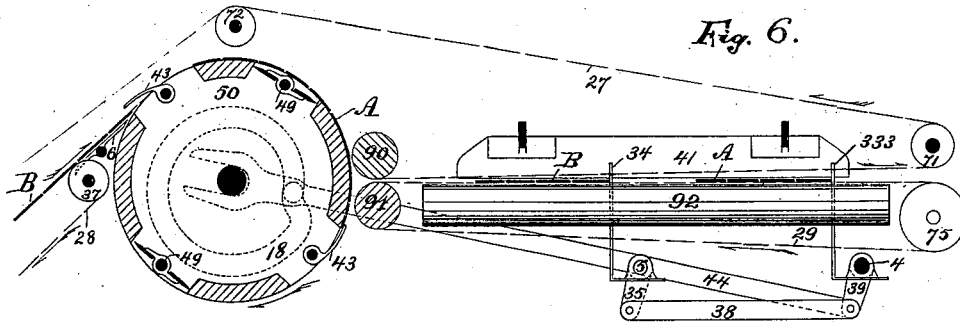

Witnesses
 Geo. H. Graham.
 Wm. C. Respe

Inventor
 W. Spalckhaver
 By Munson & Kiliff
 Attorneys

W. SPALCKHAVER.
Paper-Folding Machine.

No. 204,772.

Patented June 11, 1878.

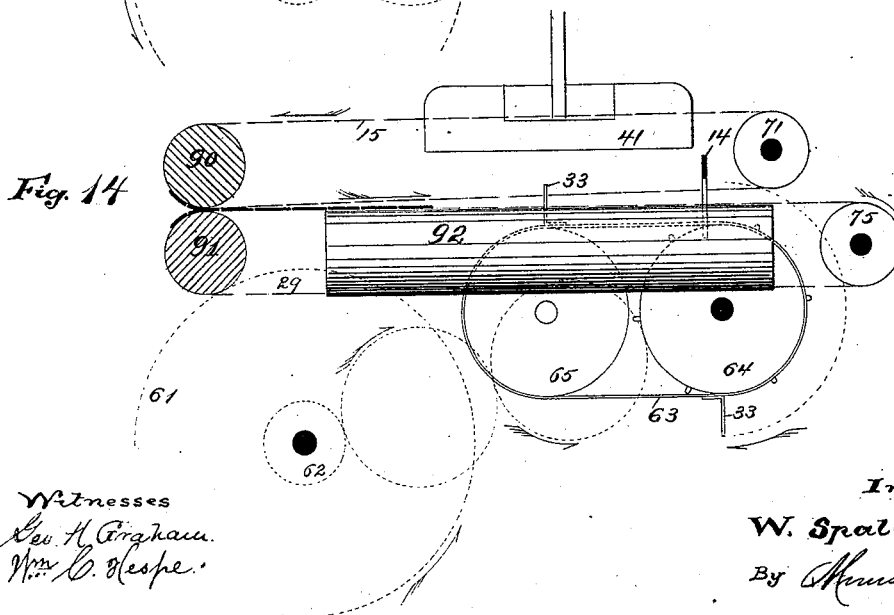
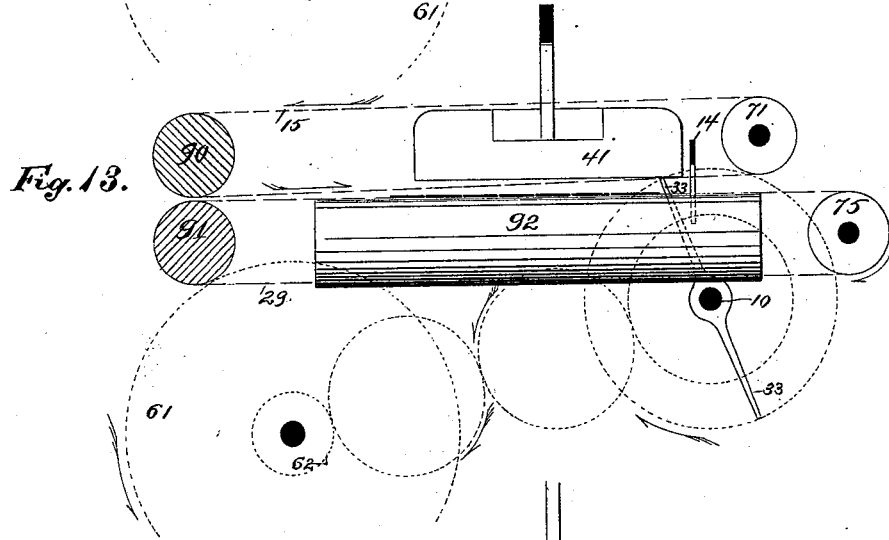
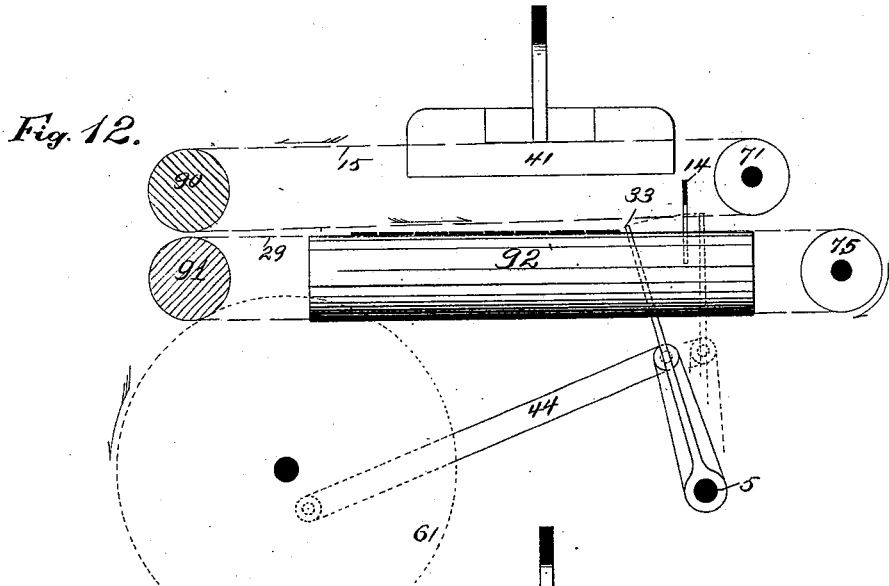

Witnesses
Geo. H. Cinghann.
Wm. C. Respe.

Inventor
W. Spalckhaver
By *Munson & Phelps*
Attorneys

W. SPALCKHAVER.
Paper-Folding Machine.
No. 204,772. Patented June 11, 1878.

Fig. 15.

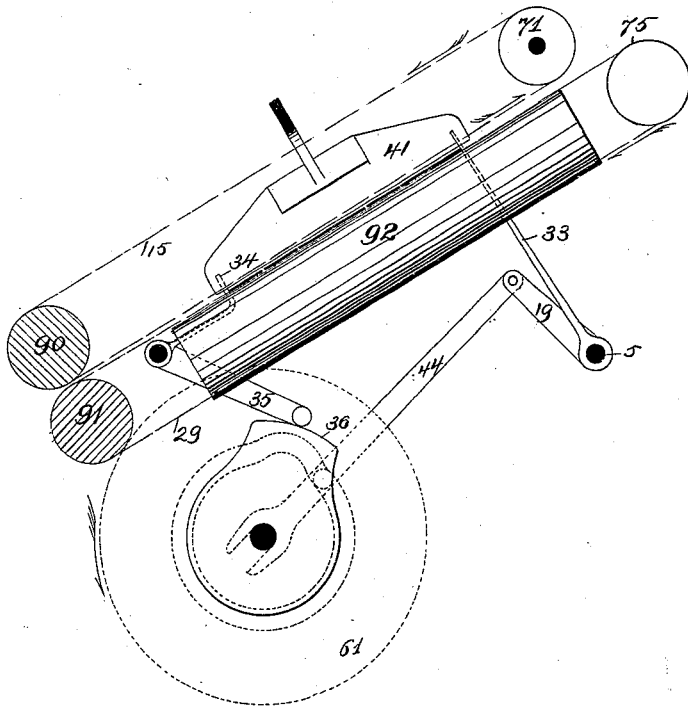
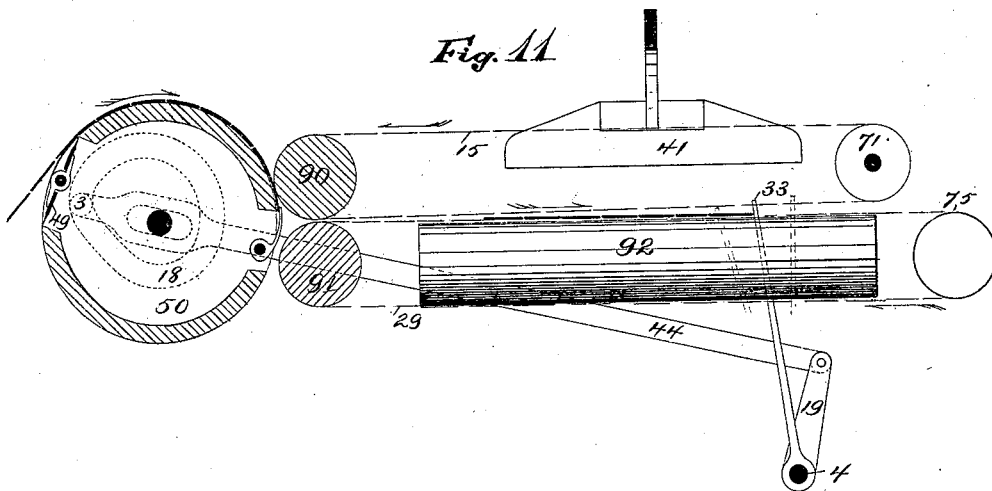

Fig. 11.



Witnesses
Geo. H. Graham.
Wm. C. Respe

Inventor
W. Spalckhaver
By *Newton & Schupp*
Attorneys

UNITED STATES PATENT OFFICE.

WILLIAM SPALCKHAVER, OF BROOKLYN, ASSIGNOR TO R. HOE & CO., OF
NEW YORK, N. Y.

IMPROVEMENT IN PAPER-FOLDING MACHINES.

Specification forming part of Letters Patent No. 204,772, dated June 11, 1878; application filed
March 15, 1878.

To all whom it may concern:

Beit known that I, WILLIAM SPALCKHAVER, of the city of Brooklyn, Kings county, New York, have invented an Improvement in Folding-Machines; and I do hereby declare that the following specification is a full, clear, and exact description of the same, reference being had to the accompanying drawings, forming a part thereof.

This invention relates to that class of mechanisms known as sheet-controlling devices, which are chiefly applied to paper-folding machines, and operate to govern the movement of or to register the sheet in proper position to be folded.

The invention consists, principally, in a sheet-controlling device which is automatically moved into or across the plane in which a sheet travels to intercept and govern the movement or position of the same; but it also includes various constructions thereof and combinations of mechanisms therewith, all of which will be more particularly hereinafter set forth.

In the accompanying drawings, Figure 1 is a side elevation of a folding-machine embodying the principal improvement; Fig. 2, a plan or top view, Fig. 3 a rear elevation, and Figs. 4 and 5 are longitudinal sections, of the same; while Figs. 6 and 7 are longitudinal sections, and Figs. 8 and 9 plan views, of a machine provided with my improvements, and with a primary folding mechanism adapted to fold two sizes of sheets; Fig. 10 showing a modification of the same, wherein the primary folding mechanism is adapted to fold one size of sheets only. Fig. 11 shows a similar mechanism, and illustrates a modified form of the sheet-controlling device; while Figs. 12, 13, 14, and 15 show further modifications of my improvements.

In order to a perfect understanding of the purpose and operation of the principal feature of the present invention, the machine illustrated in Figs. 1 to 5, in which it is embodied, will first be described.

As is well understood, a mechanism for controlling the movement of a sheet, either folded or to be folded, though adapted to all rapidly-operating folding-machines, is espe-

cially desirable in that class which are attached to or form part of a perfecting or web-printing machine, which, as is well known, operates with great rapidity, and prints a web upon both sides, cuts the same into sheets, and delivers the latter to a folding apparatus capable of running at such a speed as adapts it to fold the entire product of the printing-machine.

The cutting-cylinders only of such a web-printing machine are here represented, for the reason that the printing mechanisms (forming no part of the present invention) may be of any common or approved form, and are well known in the art. These cutting-cylinders 21 22 are geared together by toothed wheels 51 52, as usual, and will receive motion by being geared to a toothed wheel on one of the type or impression cylinders. Their cutting devices may be the groove 23 and blade 24, or any other approved mechanism whereby the web is divided, or partially divided, transversely on the lines which separate it into proper-sized sheets.

The end of the web 25, (here shown for convenience of illustration as coming from a roll, 26,) passing between these cylinders 21 22, is led between conveying-tapes 27 28 to the folding apparatus. The tapes 27 are stretched from pulleys 70, near the cutting-cylinder, around breaking-pulleys 80, or it may be a cylinder, thence around the upper folding-roller 90, out over the second folding-rollers 92 93, and return over leading-pulleys 71-72 to the pulleys 70. The tapes 28 are stretched from pulleys 73 under the pulleys 70, pass around the breaking-pulleys 80, and over the surface of the folding-roller 90, from which they descend vertically for a distance, and return under pulleys 74 to the pulleys 73. A third set of tapes, 29, are stretched from the lower folding-roller 91 to pulleys 75, passing over the second folding-rollers 92 93.

The shaft of the breaking-pulleys 80 carries a toothed wheel, 57, and is so moved by means of a train, 56 55 54 53, of such wheels from the wheel 52 that the breaking-pulleys run with a greater surface speed than do the cutting-cylinders; and consequently, if the cylinders 21 22 only partially divide the web when its end

is clamped by the tapes upon the surface of the breaking-pulleys 80, and thereby caused to take up their increased speed, said web will be parted on the line of partial severance, and the sheet thus detached from it will move with an accelerated speed and be separated a distance, as at 20, from the end of the web; or if the cylinders 21 22 wholly divide the web, then each sheet, as it is clamped upon the breaking-pulleys, will be accelerated and separated in like manner from the following sheets; but in this latter case guides or conductors, which may be either rigid or flexible, will conduct the leading end of the web into the nip of the tapes 27 28, as is well known in the art. This separation of the sheets provides for their further manipulation without interfering one with another.

The folding-blade 40 is carried at the ends of arms 42, fast upon a shaft, 32, which is rocked by means of an arm, 31, also fast on said shaft, and provided with a stud or friction-roller, 2, which runs in a cam-groove, 30, cut in the inner face of the toothed wheel 55, whereby the said folding-blade is vibrated from the position shown in Fig. 5 to that shown in Fig. 4, so as to enter between the folding-rollers 90 91, as therein shown.

The parts are so timed that a sheet advanced by the tapes 27 28 passes by the rollers 90 91 until its leading half droops before them, as in Fig. 4. The folding-blade 40 is then vibrated and doubles the middle of said sheet between the rollers 90 91, from which it emerges once folded, and is conducted out over the second folding-rollers 92 93 and under a folding-blade, 41. The upper folding-roller 90 is spring-seated, so as to readily permit the passage of inequalities in the paper, and is geared to its companion 91, so that the two will revolve in unison.

One of the folding-rollers 92 93 may be spring-seated, and the two are geared together by toothed wheels 58 59, and driven by a pulley, 76, geared by a pinion to a toothed wheel, 60, fast on the cross-shaft 9, which is driven from the cutting-cylinder 21 by means of bevel-gears 45 46, as is well shown in Fig. 1. The sheet is doubled between these rollers 92 93 by means of a folding-blade, 41, whose supporting-arms are keyed upon a rock-shaft, 8, the downward movement of said blade being imparted by means of a rock-arm, 47, which rides upon a cam, 48, fast upon the cam-shaft 9, and its upward movement by the coiled springs on the shaft 8, one end of said springs being fastened to the arms and the other to the frame-work.

As is well known to those skilled in the practical working of folding-machines, when succeeding sheets are to be folded across their line of travel a vibrating folding-blade, such as 40, may fold them with great rapidity, because they are folded without retarding their speed; but when they are to be cross-folded it is necessary that the travel of the sheets shall be stopped, and also that the first sheet

shall have entirely passed through the cross-folding rollers, such as 92 93, before the succeeding sheet shall have entered over them, so that the last sheet shall not encounter the preceding one and become buckled up; but to accomplish this the cross-folding blade, such as 41, must move with extreme rapidity.

One of the results of my improvements is the reduction of the number of vibrations of such a folding blade one-half by arranging the mechanisms so that two sheets may be simultaneously folded at each vibration of the folding-blade, as will now be explained.

The folding-blade 41 and the rollers 92 93 are made long enough to act upon two sheets at once, and said blade is thus required to vibrate but once in folding two sheets. But in thus simultaneously folding two sheets, which follow each other and are carried out so as to occupy different positions in the same plane under the folding-blade 41 and over the folding-rollers 92 93, it is essential that each sheet be independently registered in its proper place over said folding-rollers. I accomplish this by placing one stop or sheet-controlling device at or near the extreme ends of the rollers 92 93, and another at or near a point midway between the ends of said rollers, which latter stop or sheet-controlling device is a movable device, as the arms 34, and capable of being carried into or across the plane in which lies the pathway of the sheets, so as to intercept a sheet traveling in said pathway when it is to perform the office of arresting a sheet, and also capable of moving out of said plane when a sheet is to pass beyond the point occupied by it.

The sheet-controlling device may consist of a number of right-angled arms, 34, fixed upon a shaft, 5, which is moved by a rock-arm, 35, and a properly-shaped cam, 36, fast on the cam-shaft 9, the operation being to alternately rock said arms 34 from the position shown in Fig. 4 to that shown in Fig. 5. These movements are so timed that the sheet-controlling device constituted by the arms 34 will act in harmony with the mechanisms which feed forward the sheets over the folding-rollers 92 93 and the folding-blade which doubles them through said rollers, as will appear from the operation. As the sheets are delivered from the rollers 90 91 they will be carried by the tapes 27 29 out over the folding-rollers 92 93, and will, of course, preserve the space 20 by which they have been separated through the accelerating action of the breaking-pulleys 80, which space is now increased by the folding of the sheet, which operation reduces it to one-half its former size. As the leading one, A, of a pair is thus delivered and is carried out by the tapes 27 29, the shaft 9 will have so far rotated as to permit the arms 34 to rest in their lowest position, as in Figs. 1 and 4, where their ends are below the plane in which said sheet is traveling, while the folding-blade 41 remains in its raised position, as shown. When, however, the tail of said sheet A has passed

the point occupied by said arms 34, the rotation of the shaft 9 will have brought the cam 36 into position to act upon the rock-arm 35, and said arms 34 will be quickly vibrated upward, so as to cross or obstruct the pathway of the succeeding sheet B, as in Fig. 5, which sheet will abut against said arms 34, and thereby have its further movement controlled or be intercepted in its travel and stopped in proper position or register for its next fold. The tapes 27 29 will be slightly separated as they recede from the rollers 90 91, so that they may move over the sheet with frictional contact enough to drive it when it is not controlled by the arms 34 or the fixed stop 14, and at that time slip over its surface without causing it to buckle up against said arms or stop. The movements of the parts are such that the sheets A and B will be registered by the fixed stop 14 and the arms 34, and the moment this is accomplished the cam 48 will come into action and quickly vibrate the folding-blade 41 to double the two sheets A and B simultaneously through the folding-rollers 92 93. The blade 41, quickly rising, assumes its highest position. The arms 34 then descend to their lowest position, and the operation is repeated. By the use of this improved sheet-controlling mechanism the accurate folding of two sheets is simultaneously effected, while the number of vibrations of the folding-blade is lessened one-half. The succeeding folds may, if desirable, be imparted to the sheets by similar mechanisms. Unfolded sheets having a sufficient space between them might be carried directly over the folding-rollers 92 93, and receive their first fold by being doubled through them by the folding-blade 41, as is apparent.

It is obvious that the folding mechanism imparting to the sheets their first fold may be of various constructions; and though the vibrating blade 40, coacting with the folding-rollers 90 91, is a form advantageously suited to some machines, the mechanisms shown in the Patent No. 180,880 to R. M. Hoe, August 8, 1876, may be employed, or a rotating folding mechanism used, such as is illustrated in Figs. 6, 7, 10, and 11; or any of the folding mechanisms may be adopted which are contained in the patents granted to S. D. Tucker, numbered and dated as follows: No. 171,196, December 14, 1875; No. 188,987, March 27, 1877; No. 191,494, May 29, 1877; No. 192,034, June 12, 1877; No. 196,502, October 23, 1877; or Nos. 197,693, 197,694, and 197,700, November 27, 1877.

In an apparatus provided with a rotating carrier, 50, supporting one or more rotating folding-blades, as 49, (see Figs. 6 and 7,) which are automatically operated to double a sheet into the nip of folding-rollers 90 91, and with or without grippers 43 to hold the leading end of the sheet, as is described in the aforesaid patents, the tapes 29 will be arranged, and the tapes 27 will extend from pulleys, as 70, near the cutting-cylinders, as in Fig. 4, while

the tapes 28 will be stretched from pulleys 73 near the said cutting-cylinders, as in said figure, and return over pulleys 37, situated near the periphery of said carrier 50, and the space between the said pulleys 37 and carrier 50 will be bridged by short conductors, as 6.

In this apparatus movable stops or sheet-controlling arms 333 are combined and arranged to operate in like manner as are the arms or sheet-controlling devices 34, being mounted upon a cross-shaft, 4, and connected with the arms 34 by rods 38, which are pivoted to the rock-arms 35 39. These arms 333 and 34 are, moreover, simultaneously vibrated by means of a connecting-rod, 44, pivoted to a rock-arm, 19, at one end of the shaft 4, Fig. 8, which rod 44 is reciprocated by means of a cam-groove, 18, formed in the head of the carrier 50, or in a disk attached to its shaft, as will be readily understood, and thus both sheets will be stopped and registered; and as this apparatus is designed to fold both large and small sheets, the folding-rollers 92 93 are made continuous, and the shaft 5, instead of running entirely across the machine, (where it might interfere with the passage of the sheets,) is made in the form of two short shafts, Figs. 8 and 9, which are journaled in long supporting-sleeves 77 fixed to the side frames.

In an apparatus like the present, which is designed to fold both large and small sheets, which sheets are but partially severed from the web, the cutting-cylinders must be placed a distance from the carrier 50 which is at least equal to the length of the large sheets, in order that each sheet may be torn from the web and separated therefrom, the carrier 50 being made larger, or otherwise caused to have a surface speed which is greater than that of the cutting-cylinders; and when small sheets are to be manipulated it will be necessary to interpose breaking-rollers between the carrier 50 and said cutting-cylinders, as is described in the aforesaid Patent No. 197,694.

With the apparatus arranged as in Fig. 6, the small sheets conducted by the tapes 27 28 to the carrier 50 will be seized by one set of the grippers 43, carried past the folding-rollers 90 91, released from the grippers, and doubled by one of the folding-blades 49 into the nip of said rollers, as is described in said Patents Nos. 171,196 and 191,494, and will emerge therefrom and be directed over the folding-rollers 92 93; and the mechanisms will be so timed that both of the sheet-controlling arms 333 34 will remain in their lowermost position (as are the arms 34 in Fig. 7) until the tail of the sheet A has passed the point occupied by said arms 34, when both will be rocked upward by the action of the cam 18, thus carrying the arms 333 in advance of sheet A, and the arms 34 in advance of the following sheet B; and these sheets will respectively be registered against these stops, as in Fig. 6, which will control their onward movement, and hold them in proper position to receive their second folds, which will be accomplished by the de-

scent of the folding-blade 41, operated as before described. This done, the blade 41 rises, the sheet-controlling arms 33 34 are rocked out of the plane occupied by the pathway for the sheets, and the two following sheets are received and folded in like manner.

If it is desired that this apparatus shall operate to fold large sheets, one of the folding-blades 49 and one set of the grippers 43 may be made removable, whereby one folding-blade 49 may be interchanged with one set of the grippers, as shown in Fig. 7, and fully described in said Patent No. 197,694, and the carrier thus become adapted to fold large sheets. The sheet-controlling arms 34 will also need to be thrown out of action, which may be done by disconnecting the rods 38 from the rock-arms 35 39, when said stop will remain in its lowermost position, as in Fig. 7. Thus arranged, the carrier 50 will receive and fold full-sized sheets, which will be carried out by the tapes 27 29, registered by the arms 333, and a second timefolded at right angles to the primary fold by the blade 41 and rollers 92 93. It is not essential that these sheet-controlling stops shall be placed beneath the folding-rollers 92 93, as they will operate as effectively if arranged above said folding-rollers, as in Fig. 10. Their structure, when they are so placed, is not essentially changed, though their vibrations will be the reverse of those imparted to them when arranged as in Figs. 6 to 9. The connecting-rod 44 in this arrangement is shown as receiving motion from a cam-wheel, 17, which is rotated by a toothed wheel, 16, on the shaft of the carrier 50; and though said carrier is of a diameter suited to the manipulation of small-sized sheets, its structure and mode of operation, fully described in Patent No. 197,693, are not essentially different from that already set forth, all of which will be readily understood.

The sheet-controlling arms may not only act as stops to arrest the sheets at the proper points to secure their correct register for folding, as heretofore described, but may be so operated as to slow down the speed of such sheets, and thus gradually bring them to a state of rest. This arrangement and mode of operating them is shown in Fig. 11, wherein the sheets, either flat or once folded by the rotary folding-blade 49 in the carrier 50, or any other folding mechanism, are received from the rollers 90 91, and by means of tapes 15 29, (separated in like manner as are the tapes 27 29,) stretched therefrom to the pulleys 71 75, conducted out over the folding-rollers 92 93, as before described. For the purpose of this explanation, the carrier 50 is shown as provided with but one folding-blade 49.

The rollers 92 93 and folding-blade 41 are adapted to operate upon a large sheet, and only one set of the sheet-controlling arms is illustrated. Its form is shown to be that of straight arms 33, hung on a shaft, 4, which is rocked through an arm, 19, by a connecting-rod, 44, reciprocated by the cam 18, which is

driven from the primary folding apparatus or printing-machine. This cam 18 is so shaped as to impart the proper vibrations to said arms 33, whereby their rearward movement will be so timed that it shall be slower than that of the conducting-tapes 15 29, and gradually decrease until said arms come to a state of rest, whereby they will cause the sheet which comes into contact with them to be controlled in its travel and move with their speed, and thus be gently stopped and registered evenly and correctly in position to be folded through said rollers 92 93.

A sheet emerging from the rollers 90 91 will be conducted onward by the tapes 15 29, travel at their high speed, and come into contact with the ends of the arms 33 while they are moving in the same direction with it, but at a somewhat slower speed than the sheet is traveling. Said sheet will thus be partially arrested and forced to take up the gradually-diminishing speed of said arms in its further onward movement until they reach a state of rest. When the said arms have reached the limit of their rearward movement, which is while the stud or friction-roller 3 on the end of the rod 44 is passing through the lowest part of the cam 18, they will momentarily rest there, and the sheet will thus be held motionless and in register. At this time the folding-blade 41 will descend to double said sheet through the folding-rollers 92 93, and quickly rise again. As the sheet disappears through the rollers the arms 33 will be vibrated forward to repeat this operation upon a new sheet.

These sheet-controlling devices may also coact with a fixed stop, as 14, in registering the same sheet. Examples of this operation are shown in Figs. 12, 13, and 14, in each of which views the folding-rollers 90 91, folding-blade 41, folding-rollers 92 93, and carrying-tapes 15 29 are arranged as last hereinbefore described.

In consequence of the great surface speed which the sheets have when they pass through the rollers 90 91 and out over the rollers 92 93, it follows that if said sheets are projected directly against the fixed stop 14, which registers them over the folding-rollers 92 93, their momentum will cause the sheets to strike said stop with great force, which will make them buckle up or otherwise become disarranged and out of proper position or register. This defective operation is overcome by the action of the controlling device or movable arms 33. In Fig. 12 these arms 33 are shown as mounted on the rock-shaft 5 and operated by means of a crank-wheel, 61, whereby said arms are moved alternately toward and from the rollers 90 91, and pass by the fixed stop 14, which is recessed at the proper places to permit this movement of them. This crank-wheel may have a toothed periphery, and be thereby driven from the toothed wheel 7 on the end of the

folding-roller 91, (see Fig. 3,) or be otherwise actuated to operate the arms 33 in proper time.

As the sheet emerging from the rollers 90 91 is carried out over the rollers 92 93 its leading-edge will come into contact with the slower-moving arms 33, which have been vibrated into its path of travel, and will thereby be controlled so as to move slowly up to the fixed stop 14, against which the sheet will be carried slowly enough by the decreasing motion of the crank and arms 33 to allow it to be gently registered against the same, while the arms 33 leave it and retreat slightly behind said stop, as in dotted lines, Fig. 12. The folding-blade 41 then operates to fold the sheet between the rollers 92 93, which deliver it. The blade rises, the sheet disappears, and the arms 33 begin their forward movement, while a new sheet is fed forward by the tapes 15 29, and the operation is repeated.

In the mechanism shown in Fig. 13 the sheet-controlling arms 33 are arranged upon a revolving shaft, 10, which is driven by means of a train of toothed wheels, to which motion is imparted by a pinion, 62, on the shaft of the wheel 61. Their mode of operation is, however, not essentially different from that last hereinbefore explained, since, as before described, they rise into the pathway of the sheet and pass through recesses in the fixed gage 14; but, instead of making a reverse movement to repeat that operation, they pass onward by a rotative movement, and are thus returned to repeat the operation. In order to secure the proper speed of travel, two such arms project at opposite points from said shaft, and, of course, are alternately brought into position to control the sheet.

Fig. 14 shows a modification of the rotative arrangement of the arms 33, said arms being made to project from a belt or belts, 63, which run over wheels or pulleys 64 65, one of which is provided with teeth or pins, which take into holes in said belt, and thus insure its positive movement. The pulley 64 is driven by a train of wheels from the pinion 62, and both of said pulleys 64 65 are so arranged as to stretch the belt 63 in such a position as to carry the stops 33 a distance through the pathway of the sheets and along under the fixed gage 14.

Sheet-folding mechanisms are sometimes constructed with their folding-rollers arranged in an inclined position, whereby an economy of space is secured, and the stoppage and registration of the sheets are partially aided by gravity.

Fig. 15 shows a machine thus constructed, the folding-rollers 92 93 of which are so inclined that the sheet from the rollers 90 91 is caused to travel upward by the action of the tapes 15 29. The sheet-controlling arms 33 may, in this machine, be adapted to aid in registering the sheet by its tail end, as will now be explained. In order to register a sheet in this manner, it is obvious that there must be a sheet-stop at or near the rear ends of the

folding-rollers 92 93, which shall enter or cross the pathway in which the sheet must travel in being fed beyond it, and also that while the sheet is passing over it the said sheet-stop must not obstruct the pathway of the sheet. This is provided by the movable sheet-stop 34, which is constructed and operated substantially as before described with reference to Figs. 1 to 5, though, as shown in this Fig. 15, the rock-arm 35 has its actuating-cam 36 fixed upon the shaft of the cam-wheel 61, which operates the arms 33. The movements of these arms 33 34, while produced in the manner just described, are so timed that the stops 33 and 34 will act in harmony with each other and the devices which feed or fold the sheet, and deliver the same over the rollers 92 93, as will appear from the following description of the operation.

As the sheet emerges from the rollers 90 91, and is carried by the tapes 15 29 so far over the rollers 92 93 as to pass the point occupied by the stop 34, the said stop will remain in its lowermost position, as in Fig. 1, the cam 36 being so shaped and operated as to effect the same; but as soon as the tail end of the sheet has passed said point occupied by the stop the cam 36 will operate to quickly raise said stop into the position shown in Fig. 15, where it stands across the pathway in which the sheet has traveled. Now, by preference, the sheet-controlling arms 33 will be so timed in their movements that they shall first gradually stop the sheet and then begin a reverse movement, which shall push or force the sheet backward until its rear edge is registered against the stop 34. This done, the folding-blade 41 descends to double the sheet through the folding-rollers, the stop 34 retreats to its lowermost position, the reverse movement of the arms 33 is effected, and a new sheet is delivered by the rollers 90 91 and tapes 15 29 to be manipulated, as before described.

The movable sheet-controlling device or arms may obviously be carried into and out of position to obstruct or clear the pathway for the sheets by any other automatic means than that described which will impart to it a to-and-fro movement.

This sheet-controlling device may be combined with folding-machines wherein but one set of tapes, as 29, are provided to carry the sheet over the folding-rollers, and a set of guards or rods are placed above said tapes to secure the position of the sheets; or in a machine where the sheets are driven out over the said folding-rollers between two sets of guards or rods by means of the rollers, as 90 91, as is common in folding-machines.

Though, as thus far described, the folding-rollers 92 93 are shown to be of a length greater than that of two sheets, being cut away near their middle portions to accommodate the shaft 5, and thus practically forming two sets of rollers, and the folding-blade 41, co-operating therewith, is shown to be a single blade, it is obvious that there may be

two independent sets of aligned folding-rollers, each supplied with independent folding-blades, and that in this latter case the mechanisms may operate to fold the first sheet a little in advance of a like operation upon the second, it being only necessary to time the mechanisms operating the folding-blades accordingly; and, furthermore, that a rotating folding-blade, or two such, may be substituted for the blade 41, as in Patent No. 191,494.

Though this controlling device, in any of its described forms or modes of operation, will manipulate an unfolded sheet of paper when the same is of high quality, and therefore strong, it will, in practice, generally be used to operate upon a sheet delivered from the rollers 90 91 in a once-folded condition.

It is furthermore to be understood that this sheet-controlling device in any of its constructions may be introduced singly, or duplicated to any extent to co-operate with single folding-rollers, or any number of aligned folding-rollers, without regard to the structure of the folding mechanisms which double the sheet operated upon through said folding-rollers, or whether the sheets manipulated are unfolded or are folded one or more times.

The combination, with a fixed gage-bar or a sheet feeding or folding mechanism, of a mechanism for controlling the movement of a traveling sheet, is not broadly claimed herein.

The mechanisms shown in Figs. 11 to 15, inclusive, though embodying the broad invention contained herein, are not specifically claimed, since they form the subject-matter of another application.

What, therefore, is claimed is—

1. The combination, with folding-rollers over which sheets to be folded are conducted, of a sheet-controlling device provided with mechanisms whereby it is automatically moved

across the plane in which a sheet travels to intercept and govern the movement of the same with respect to said rollers, all substantially as described.

2. The combination, with folding-rollers, as 92 93, of a length suited to the manipulation of two sheets, and a folding mechanism co-acting therewith, of a sheet-controlling device automatically moved across the plane in which the sheets travel, and operating so that the passage of one sheet is unobstructed while the succeeding sheet is intercepted, substantially as described.

3. The combination of the folding-rollers, as 92 93, folding-blade 41, stop 14, and a device automatically moved across the plane in which a sheet travels to intercept and control the same, all substantially as described.

4. The combination, with folding-rollers, as 90 91, and a co-operating folding-blade, of folding-rollers, as 92 93, placed at right angles thereto, and a folding-blade co-operating therewith, and a sheet-controlling device provided with mechanism whereby it is automatically operated to intercept alternate sheets, all substantially as described.

5. The combination, with folding-rollers adapted to fold both large and small sheets, of a sheet-controlling device provided with mechanism for automatically moving it across and out of the plane in which the sheets travel to intercept alternate sheets, which mechanism is constructed so as to be thrown out of operation to render said controlling device inactive, all substantially as described.

In testimony whereof I have signed my name to this specification in the presence of two subscribing witnesses.

WILLIAM SPALCKHAVER.

Witnesses:

CHAS. W. CARPENTER,
FRANKLIN T. GROSS.