

H. A. WEBBER.
Grain-Separators.

No. 204,778.

Patented June 11, 1878

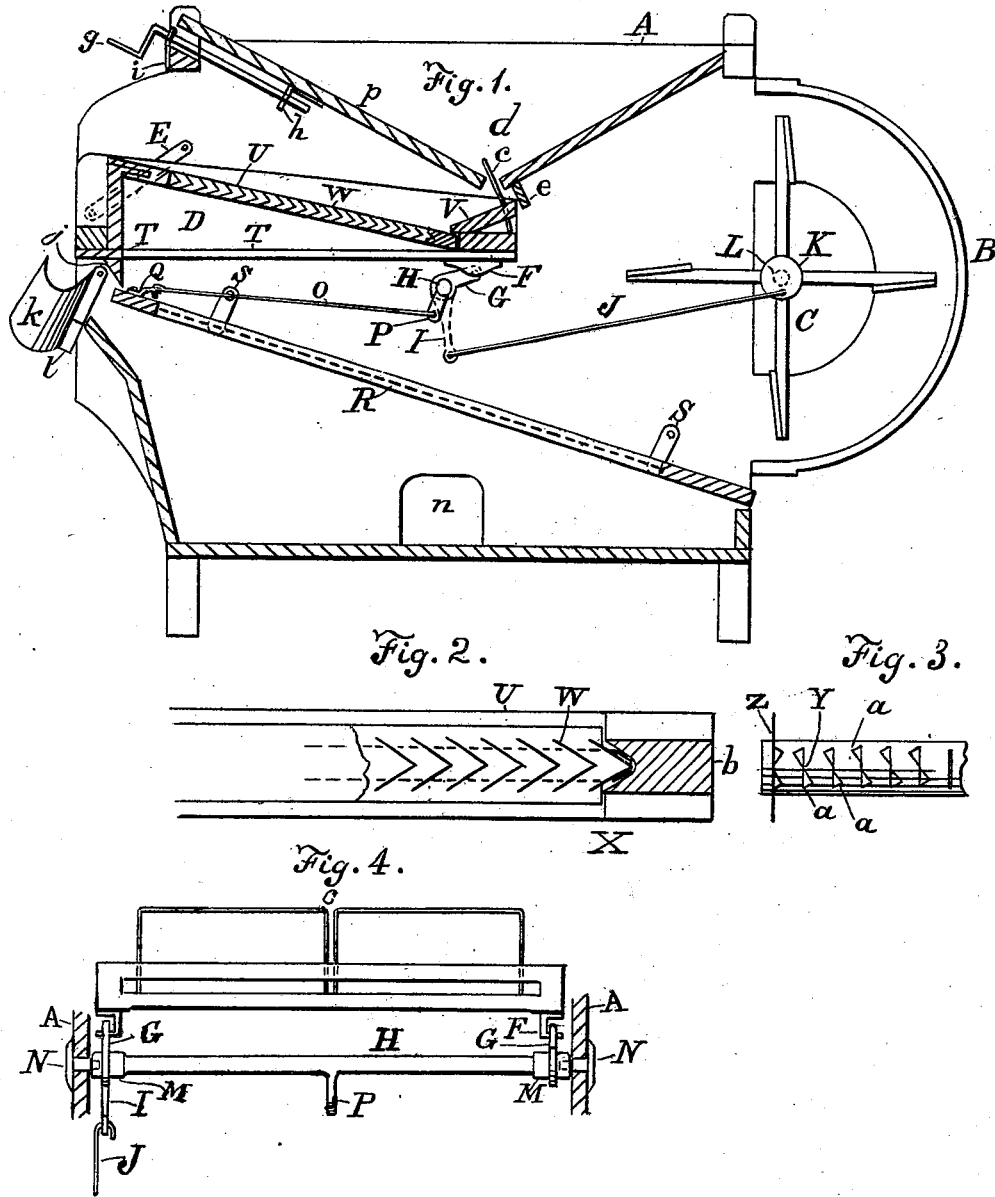

Witnesses:
Theo. Mungen
John D. Dornofue.

Inventor:
H. A. Webber
by H. J. Eunit,
Attorney.

UNITED STATES PATENT OFFICE.

HENRY A. WEBBER, OF ROCKTON, ILLINOIS.

IMPROVEMENT IN GRAIN-SEPARATORS.

Specification forming part of Letters Patent No. **204,778**, dated June 11, 1878; application filed May 27, 1878.

To all whom it may concern:

Be it known that I, HENRY A. WEBBER, of Rockton, in the county of Winnebago and State of Illinois, have invented certain new and useful Improvements in Grain-Separators; and I do hereby declare that the following is a full, clear, and exact description thereof, which will enable others skilled in the art to which it appertains to make and use the same, reference being had to the accompanying drawings, and to letters of reference marked thereon, which form a part of this specification.

Figure 1 is a vertical sectional view of a machine embodying the improvements of my invention. Fig. 2 is a longitudinal vertical sectional enlarged view of the angle-sieve and its frame. Fig. 3 is a rear view of a section of the angle-sieve, showing the ends of the longitudinal ribs bent to the right and left to fasten the sieve within the V-shaped groove in the removable rear end of the sieve-frame; and Fig. 4 is a rear elevation of the shoe, rock-shaft, and agitator.

This invention has relation to improvements in grain-separators for separating oats, &c., from wheat; and it consists of a shoe suspended by hangers at its forward end, and connected by arms projecting upwardly and backwardly from a rock-shaft, having bearings in the sides of the case beneath the shoe at its rear end, said rock-shaft being operated by a rod connected at one end to a depending lever on the rock-shaft and at the other end to a crank or an eccentric on the fan-shaft, for the purpose of giving the shoe an oscillating and a longitudinal vibratory movement at one and the same time.

It further consists of a sieve the transverse ribs or partitions of which are V-shaped and slotted to permit the longitudinal ribs to pass through, said longitudinal ribs having their corners at their rear ends bent—the upper ones to the right and the lower ones to the left, or vice versa—to permit the rear end of the sieve to be inserted into a V-shaped groove in the removable rear end of the sieve-frame, for the purposes of holding it firmly within the sieve-frame.

It further consists of an inclined screen suspended in hangers beneath the shoe, and ex-

tending from the front of the shoe to the rear of the machine, and connected by a rod connected with an arm depending from the rock-shaft, which operates the shoe, to an eye upon the front end of the inclined screen, for the purpose of conveying the wheat to the point of discharge.

It further consists of a removable inclined chute or spout attached to the front of the machine beneath the shoe, to receive and convey the oats as they are blown over the end of the screen in the shoe to any appropriate receptacle; and it consists in other improvements in the construction of the machine, all of which will be hereinafter more fully described, and particularly pointed out in the claims.

In the accompanying drawing similar letters of reference indicate like parts of the invention.

The frame and casing A are of the ordinary construction, except that the drum B is made removable to expose the fan C for removal or repairs.

The shoe D is suspended within the case by hangers E, near its forward end, and is connected, by studs F or otherwise, to the arms G upon the rock-shaft H, said arms G projecting upwardly and inclining backwardly from the rock-shaft H, and being located one very near each end.

A depending arm or lever, I, inclines backwardly from the rock-shaft H, and is connected, by the rod J, to an eccentric or crank, K, upon one end of the fan-shaft L.

The rock-shaft H has collars M upon its opposite ends, into which are inserted, from the outside of the casing, studs N, which form the bearings for the rock-shaft H.

A rod, O, connecting at one end with a depending arm, P, located centrally upon the rock-shaft H, is connected at the other end to an eye, Q, fastened to the front end of an inclined screen, R, suspended in hangers S.

The interior of the shoe D has the strip T upon its sides and front end, upon which the sieve-frame U rests. The rear or lower end of the sieve-frame U passes under the edge of the inclined strip V at the rear of the shoe D.

The sieve W is composed of V-shaped transverse ribs X, slotted to permit the lon-

gitudinal ribs Y to be passed through, and provided with strips Z at the sides, to bind them together and to line the sides of the sieve-frame U. The corners *a* of the rear ends of the longitudinal ribs Y are bent, the upper ones to the right and the lower ones to the left, or vice versa, and the rear end of the sieve W enters a V-shaped groove in the removable piece *b* at the rear end of the sieve-frame U, the corners *a* serving to fasten the sieve W firmly in place; and, owing to the fact that these corners *a* act as so many braces, the sieve W will not be shaken loose by the shaking motion imparted to the shoe D.

The sides and front end of the sieve-frame U have grooves, into which the sieve W is slid from the rear end when placed in said sieve-frame. An agitator, *c*, composed of two sections, in order to shorten the wires, and thereby give them additional strength, projects upwardly from the inclined strip V through the feed-orifice at the bottom of the hopper *d*, and serves to agitate the grain and draw it through the feed-orifice aforesaid. The side of the hopper *d* next the rear of the machine is stationary, and is provided with a cut-off, *e*, upon its under side, immediately in rear of the shoe D, to prevent the blast from passing over the rear end of the shoe D. The front side *p* of the hopper *d* works in grooves in the side of the casing, and is adjusted by the hand-screws *g*, working in a threaded plate, *h*, secured to its under side, to regulate the amount of grain that may be fed to the shoe D, and in a threaded plate, *i*, fastened to the front cross-piece of the frame A, to regulate the feed. A beveled strip, *j*, traverses the front end of the shoe D, directly beneath the front wall *x* of the sieve-frame U, to prevent the blast from leaving the mill at that point.

A chute or spout, *k*, is secured to a removable tapering strip, *l*, having pins *m* in its opposite ends, one of which enters a pin-hole in the inner side of the casing, and the other is introduced into a pin-hole having a slot leading thereto, made in the opposite inner side of the casing A, directly in line one with the other, the object of the spout *k* being to catch the oats as they fall from the end of the screen W, to convey them into a receptacle placed for their reception.

The opening *n* has a sliding door, and through it access is gained to the machine beneath the inclined screen R to remove the screenings.

When the fan C is driven the rod J operates the lever I and works the rock-shaft H, which, through the arms G, gives the shoe D an oscillating motion and a longitudinally-shaking motion at the same time. The agitator *c*, which is secured to the rear end of the shoe D, receives a similar motion, and agitates the grain in the hopper *d*.

The rod O, connecting the inclined screen R with the arm P, communicates motion from the rock-shaft H to said inclined screen R, which, being suspended in the hangers S, is given the necessary shaking motion.

The hand-screw *g* may be turned to adjust the front side *p* of the hopper *d*.

The chaff is blown out at the front end of the machine, the oats fall over the chute *k*, the wheat passes through the sieve W and falls into the inclined screen R, which carries it to the rear of the machine, where it is discharged.

The shoe D may be removed by withdrawing the studs N from the collars M on the shaft H and the screws by which the hangers E are secured to the casing.

Having thus described my invention, what I claim as new and useful, and desire to secure by Letters Patent of the United States, is—

1. In a grain-separator, the shoe D, arranged to have an upward and forward movement at the feed end, and having the agitator *c* projecting upwardly and forwardly through the opening in the hopper from the inclined strip, substantially as and for the purpose set forth.

2. In a grain-separator, the cut-off *e*, secured to the under side of the hopper immediately in the rear of the shoe D, having a vertical movement at its feed end, substantially as and for the purpose set forth.

3. The angle-sieve W, having V-shaped transverse ribs X and flat longitudinal ribs Y, the corners *a a* of which are bent to the right and left, as shown, having its rear end inserted into the V-shaped groove in the removable end piece *b* of the sieve-frame U, substantially as and for the purposes set forth.

In testimony that I claim the foregoing as my own I affix my signature in presence of two witnesses.

HENRY A. WEBBER.

Witnesses:

THEO. MUNGEN,
JOHN O'DONNOGHUE.