

H. BARCLAY.

Clamp for Sewing-Machine Needle.

No. 204,789.

Patented June 11, 1878.

Fig. 1.

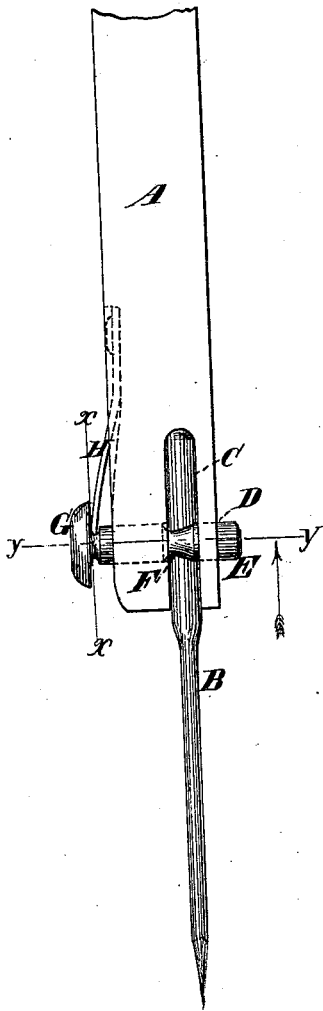

Fig. 2.

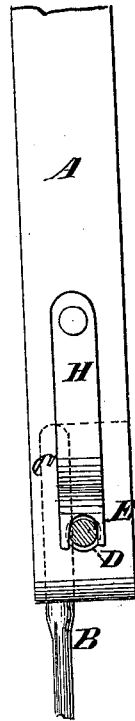
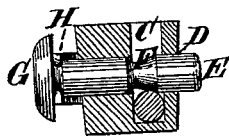

Fig. 3.



Witnesses

John Decker
Fred. Jaynce

Fig. 4.

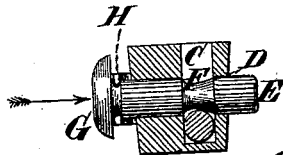

Inventor:

Henry Barclay
by his Attorneys
Brown & Allen

UNITED STATES PATENT OFFICE.

HENRY BARCLAY, OF ELIZABETH, NEW JERSEY.

IMPROVEMENT IN CLAMPS FOR SEWING-MACHINE NEEDLES.

Specification forming part of Letters Patent No. **204,789**, dated June 11, 1878; application filed March 20, 1878.

To all whom it may concern:

Be it known that I, HENRY BARCLAY, of Elizabeth, in the county of Union and State of New Jersey, have invented an Improvement in Clamps for Sewing-Machine Needles; and I do hereby declare that the following is a full, clear, and exact description of the same, reference being had to the accompanying drawing, which forms a part of this specification.

The improvement is applicable to any needle-bar or to other needle-carriers, whether they reciprocate in right lines or in an arc of a circle.

The object of the invention is to provide a more convenient means of clamping a sewing-machine needle than has hitherto been supplied. This I accomplish by my improvement, and at the same time I clamp the needle securely.

Figure 1 in the accompanying drawing is a side view of a needle-bar to which my improvement is applied. Fig. 2 is a view of the side of the same opposite to that shown in Fig. 1. Figs. 3 and 4 are each a section made on the line *yy* in Fig. 1, but each shows the clamping device in a different position from that shown in the other.

A represents the needle-bar, and B represents the needle clamped therein according to my improvement. In the said needle-bar is formed a slot or perforation, C, for the reception of the needle. Through the said needle-bar, and preferably at right angles with the said slot in the said bar, I pierce a hole, D, for the reception of the clamping-pin E. The said clamping-pin has formed therein a groove or recess, preferably, but not necessarily, so cut that its deepest part is on one side of the

middle of the groove. The said clamping-pin has a projection, preferably in the form of a head, G, for the engagement of the end of a spring, H, riveted or otherwise attached to the side of said needle-bar. The said clamping-pin has also preferably a small groove formed close to the projection or head G, for the engagement of the end of the spring H, by which means the said clamping-pin is prevented from ever dropping out when the needle is not in the needle-bar.

The form of the groove F is such that it leaves a bearing-surface of conical or wedge-like form, which, when the needle is placed in the slot or perforation C of the needle-bar and the spring H is left free to act, wedges or clamps the said needle in the said slot or perforation.

To take out or to put in a needle it is only necessary to press on the head of the clamping-pin, which releases the needle, if there be a needle clamped in the needle-bar, or allows a needle to be inserted, if required.

I claim—

The combination of the slotted or perforated needle-bar, the grooved clamping-pin, and the spring H, attached to the needle-bar and engaging the said clamping-pin, substantially as described, whereby the said clamping-pin is forced endwise for clamping the needle in the slot or perforation of the needle-bar and the groove of the clamping-pin, substantially as and for the purpose specified.

HENRY BARCLAY.

Witnesses:

LEICESTER ALLEN,
BENJAMIN W. HOFFMAN.