

J. E. GLOVER.  
Thrashing-Machine.

No. 204,813.

Patented June 11, 1878.

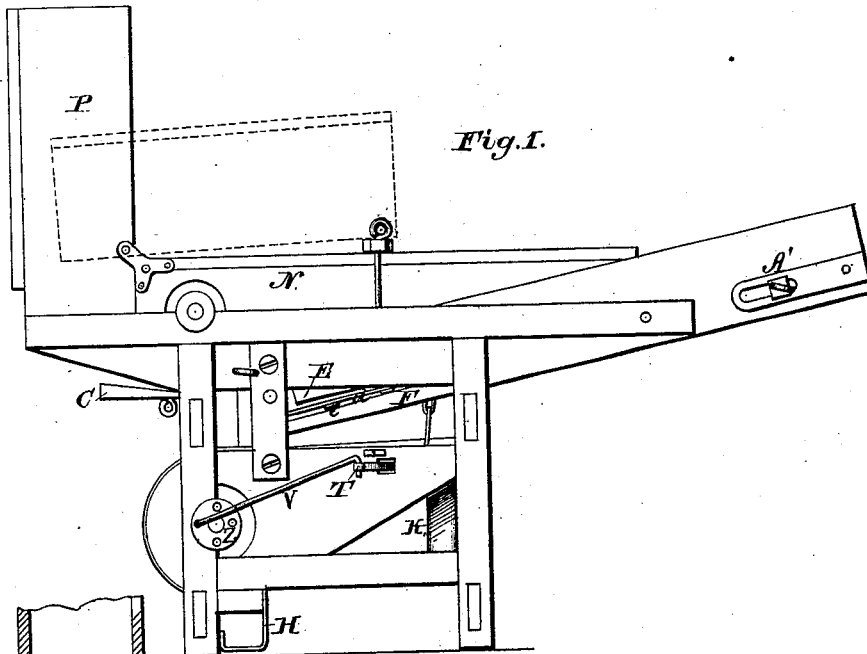

Fig. 1.

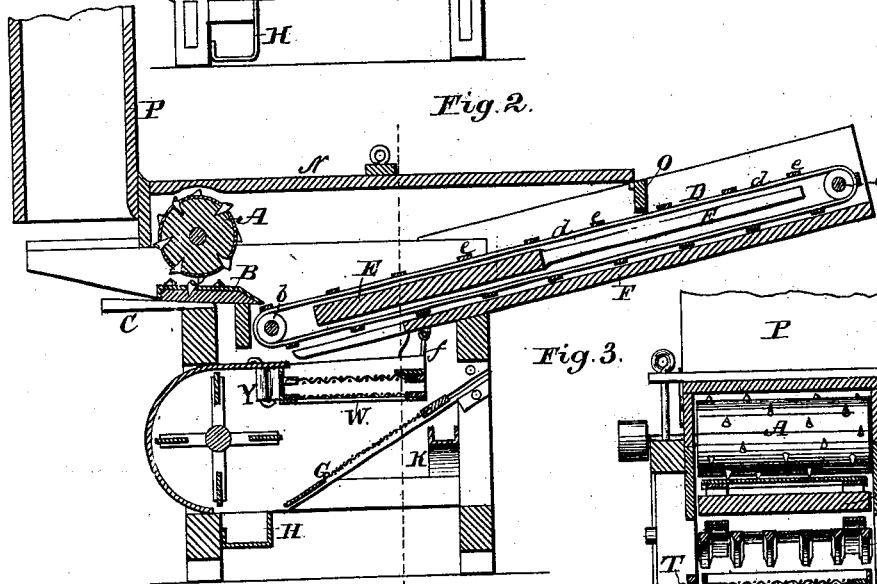

Fig. 2.

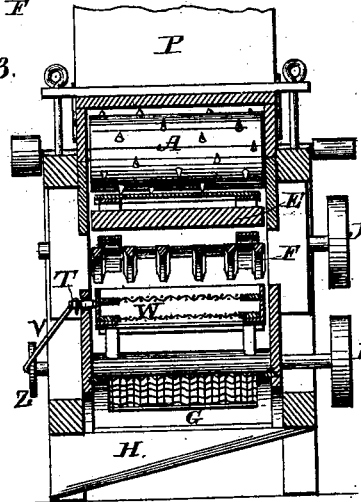

Fig. 3.

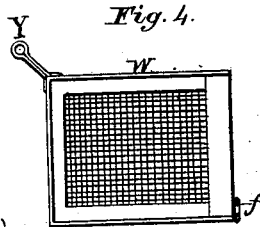

Fig. 4.

Attest.  
John Kemon  
Chas. A. Pettit

Inventor.  
John E. Glover  
By [Signature] Attorney.

# UNITED STATES PATENT OFFICE.

JOHN E. GLOVER, OF LONOKE COUNTY, ARKANSAS.

## IMPROVEMENT IN THRASHING-MACHINES.

Specification forming part of Letters Patent No. **204,813**, dated June 11, 1878; application filed February 19, 1876.

*To all whom it may concern:*

Be it known that I, JOHN E. GLOVER, of the county of Lonoke and State of Arkansas, have invented a new and useful Improvement in a Thrashing and Cleaning Machine, which improvement is fully set forth in the following specification.

This invention relates to improvements in thrashing-machines; and it consists in a novel construction and arrangement of parts, which will be hereinafter more fully described in the specification, and pointed out in the claims.

In the accompanying drawings, Figure 1 shows a side view of my thrashing-machine, and Fig. 2 a longitudinal vertical section of the same. Fig. 3 is a vertical cross-section of the machine. Fig. 4 is a detail plan view of the shoe detached.

A is the cylinder of the machine, working over the concave B, which is pivoted to the sides of the casing, and is adjusted by means of the wedge C resting on the framing. Over this cylinder is the cap-box N, having at one end the fly-door O and at the other a dust-chimney, P. This chimney is not constructed within the cap of the cylinder, but is outside of and hinged to the front edge of it, and its cross-area is equal, or nearly so, to that of the feed-board. It thus practically incloses the feed-board, and intercepts the current of dust from the cylinder. Both the fly-door and chimney are hinged to the cap N, so that the fly-door may open wider to allow straw to pass, and the chimney be turned down over the cap out of the way of the operators when it is desired to inspect or to transport the machine, should it be necessary.

Running over rollers *b c* is the straw-carrier D, consisting of endless belts *d*, connected by cross-slats *e*. The roller *c* is provided with adjustable bearings at *A'* to tighten the carrier-belts when necessary.

Beneath the upper part of the carrier is the

straw-board, which is solid for about half its length, and the remainder is made into fingers, E.

At F is a grain-board, which catches the grain falling through the slats *e* and fingers E. From the grain-board F the grain falls upon the sieve-box W, which is hung, by links *f*, at one of its two front corners from the grain-board F, and has its farther left-hand corner hinged to the casing at Y.

Attached to the nearest side of the sieve-box W is a bracket, T, having an eye to receive one end of the pitman V, whose other end is set in one of the holes in the face-plate Z, attached to the shaft of the fan, and by this means the sieve-box obtains the necessary shaking movement, which may be varied to suit circumstances by setting the cord of the pitman in different holes in the face-plate.

The grain, as it passes from the sieve W, falls upon the bottom of the fan-box G, which may either be made solid or of wire-gauze, and from thence into the shoe H.

I employ the usual form of gage-board to intercept the cut heads and waste grain, and conduct them into the trough K.

A slide is also employed, in practice, to regulate the blast or draft of the fan.

What I claim as new is—

1. The combination, with a thrashing-machine, of the draft-chimney P, arranged to cover the feed-board, and hinged to the cap N in front of the cylinder to fold down over the cap N, substantially as specified.

2. The combination of the sieve-box W, the hinge Y, supporting one corner of the feed end thereof, links *f*, bracket T, pitman V, and face-plate M, all constructed and arranged substantially as set forth.

JOHN E. GLOVER.

Witnesses:

LEMUEL C. SANDERLIN,  
CARSON C. TEDFORD.