

H. GROSS.  
Burglar-Proof Safes.  
No. 204,814. Patented June 11, 1878.

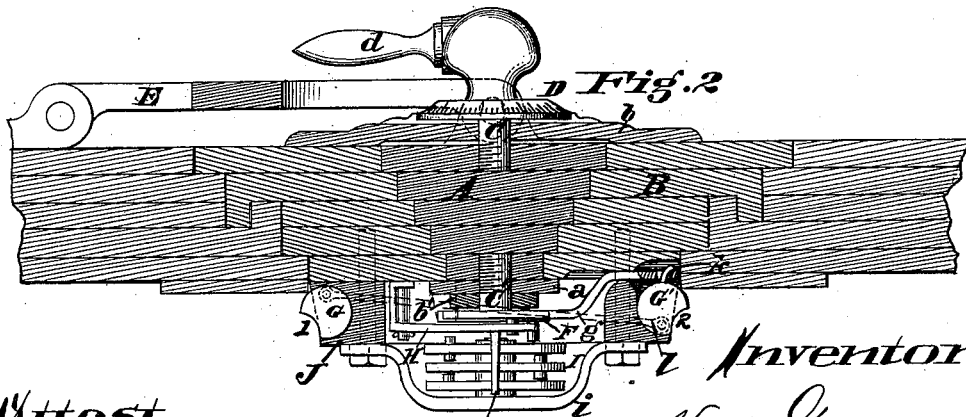
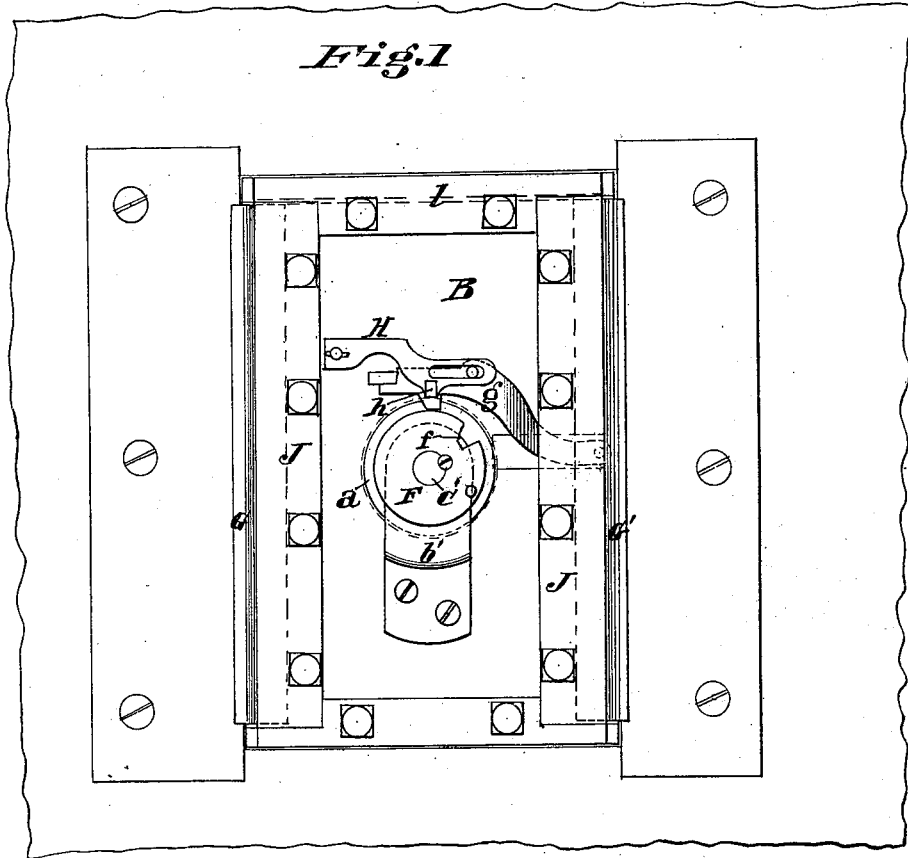

*Attest*  
*J. C. Helder*  
*W. M. Myers*

*Inventor*  
*Henry Gross*  
*By Edgar J. Gross*  
*Attorney*

H. GROSS.  
Burglar-Proof Safes.  
No. 204,814. Patented June 11, 1878.

Fig. 3

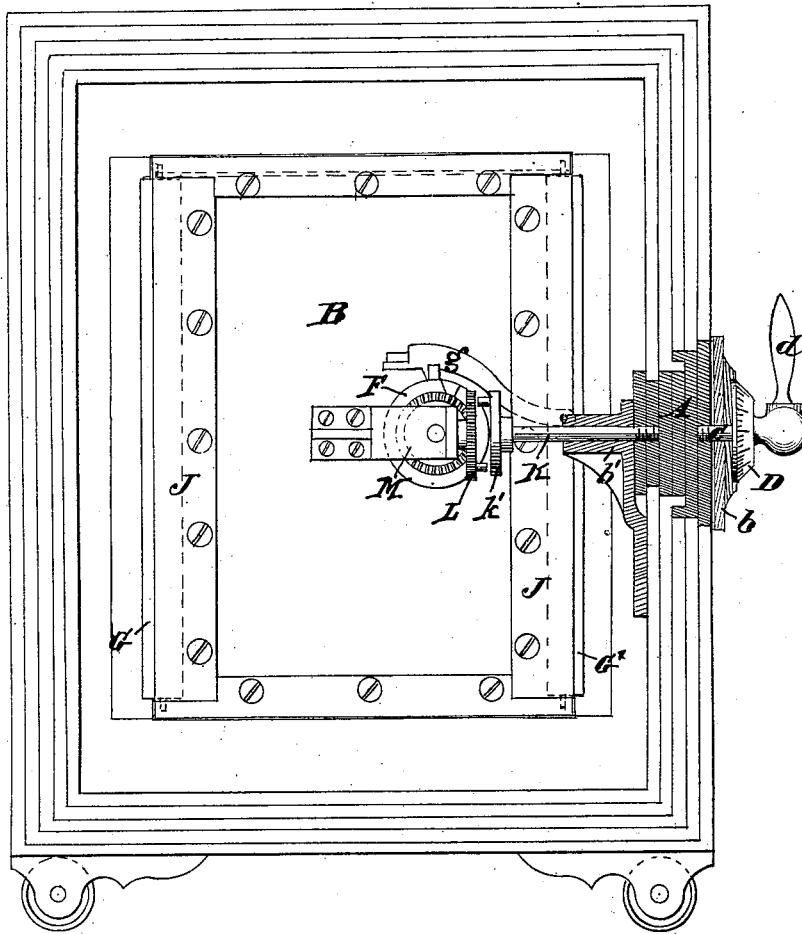
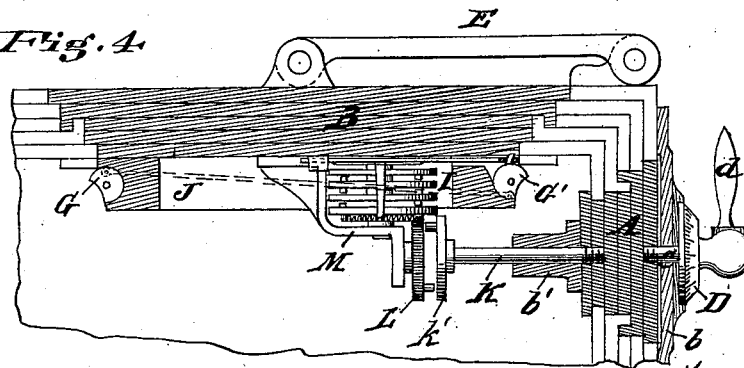

Fig. 4



Attest

J. C. Helder  
W. M. Myers

Inventor

Henry Gross  
By Edgar Gross  
Attorney.

# UNITED STATES PATENT OFFICE.

HENRY GROSS, OF CINCINNATI, OHIO.

## IMPROVEMENT IN BURGLAR-PROOF SAFES.

Specification forming part of Letters Patent No. **204,814**, dated June 11, 1878; application filed December 20, 1877.

*To all whom it may concern:*

Be it known that I, HENRY GROSS, of Cincinnati, Hamilton county, State of Ohio, have invented an Improvement in Burglar-Proof Safes, of which the following is a specification:

My invention has for its object the construction of a safe that will admit of the use of the ordinary style of door while dispensing with the arbor so prevalently in use, and at the same time admit of the use of locks and bolt-work that may be operated from the exterior of the safe; and my invention consists in the formation of a portion of the walls of the safe, by separation therefrom, into a disk which shall be secure from withdrawal, but be perfectly free to rotate, and thus possess the conditions necessary to enable the manipulation of the locks and bolt-work from the exterior of the safe.

In this manner I dispense with the ordinary means of operating the locks, viz., the arbor, which cannot be tempered in bulk to such a state of hardness as to resist drilling, and if made by joining pieces of such small size as to admit of perfect tempering it will not be proof against strong concussive shock. In fact, as above mentioned, I have provided a means of operating the locks and bolt-work equal in resistive strength to the walls of the safe, of which it forms a permanent part.

My invention has, further, for its object the simplifying of the bolt-work that secures the door of the safe in its locked position; and my invention consists, further, in the provision of one or more revolving bolts, having blanks formed in their surfaces, and so located and secured as that, when the door is locked, they will present a portion of their entire diameters as a barrier to the opening of the door, and as that, when the blanks in their surfaces are brought contiguous to the door-jambs, on account of decreased diameter, the said barrier will have been removed, and the door can be drawn or thrown from its position and opened.

My invention still further consists of minor details of construction, more fully described hereinafter.

Referring to the accompanying drawings, Figure 1 is an interior view of the front of the safe, showing door, &c., in elevation. Fig. 2 is a horizontal sectional view of the front

and door of the safe, showing the locking devices. Figs. 3 and 4 show a modified form of constructing my improved safe.

As before mentioned, the present arbors used to manipulate the locks and bolt-work of the safe have not the elements of security about them, inasmuch as when made solid they are too soft, owing to the fact that the steel of which they are made cannot be thoroughly tempered in such large quantity, and hence not drill-proof, and as, when made of small pieces that can be thoroughly tempered, they are not proof against concussive strains directed to fracture them.

In order, then, to meet and fill the above deficiencies, I have provided a disk of metal, A, as more clearly shown in Figs. 2 and 3 of the drawing. It is made of plates of welded iron and steel, exactly similar to the wall of the safe, (that is, preferably so,) and these plates are successively decreased in size toward the inner surface of the safe, and the plates of the walls stepped to match, so that the disk, when in position, cannot be driven in. The plates of which the disk is made are similar, as mentioned, to those of the body of the safe, and, being very thin, are capable of being perfectly tempered or hardened, and thus made drill-proof. Then, in order to render concussive force of no avail against it, the disk is made of such size as that the plates can be securely joined together, and as that each individual plate shall be of such size that it shall possess in itself sufficient resistive strength.

By experience I have found that the minimum average diameter of the disk A should not be less than its thickness, and its security and strength will increase from this proportion in the ratio of the increase of the diameter over the thickness. As seen in Figs. 1 and 2 of the drawings, the disk A is located in the door B, and is secured against withdrawal by the plate *a*, which is firmly secured to it, and projects beyond the line of division between the disk and the door.

In order to lessen the friction that may be caused in operating the disk, it is provided with exterior and interior lugs *c c'*, which are centrally located upon it, and rest in bearings *b b'* upon the exterior and interior of the door B. In this manner the disk is revolved

in small bearings, and the friction attendant is thereby decreased.

Upon the outer lug *c* is secured rigidly a dial, *D*, and handle *d* for operating it, the former being arranged to revolve within a rim upon the bearing *b*, which rim is provided with an index-mark, by which to gather the combination of the lock inside of the safe. The door *B* is hinged to the body of the safe by the crane-hinge *E*, so that by means thereof the door may be withdrawn squarely out, in order to get clear of tenons in the jamb and the bolt-work, which would not enable the door to be opened upon an ordinary hinge. However, any kind of hinge that will draw the door squarely out for a short distance will answer the purpose.

Secured upon the inner lug *C'* beyond the bearing *b'* is a drive-wheel, *F*, having detent *f* to engage with a dog, *g*, connected to the bolt-work.

*H* is a secondary dog, pivoted upon the safe-door, and provided with slot to engage with a pin upon dog *g*, so that they will be compelled to rise and fall together, while permitting the latter to be operated laterally by the drive-wheel, the dog *H* being provided with a lateral extension, *h*, which is arranged to bear upon a series of combination-tumblers, *I*, and be guarded by them against falling. Thus the dog that connects the drive-wheel and bolt-work is prevented from connecting until the combination of the guarding-tumblers is set.

It is evident that the dog *H* may be omitted and the dog *g* be provided with an arm, *h*, to rest upon the tumblers, the only difference in result being the necessary moving of the tumblers when the drive-wheel throws the bolts.

The tumblers are of the usual style, and are secured upon a frame, *i*, which is secured to the bolt-frame.

The bolt-work is composed of frame *J*, secured firmly to the door *B*, and of round bar bolts *G G'*, securely embedded within the frame in such position as that they will extend over, while running parallel to, the jamb of the door—that is to say, that of the entire diameter of the bolt part of it is embedded within the bolt-frame and the other part extends over the jamb of the door when the door is locked, and prevents its opening. Of course, in this condition of affairs the bolts would be inoperative, and hence they are arranged to be revolved by the dog *g*; and at

points necessary there are formed blanks 1 and 2 in their peripheries, so that when brought contiguous to the jambs of the door the presence of these blanks removes the obstruction of that part of the diameter of the bolts equal thereto which prevented the opening of the safe before, and consequently allows the opening of the door. The dog *g* is pivoted or hinged to one of these bolts, as seen at *k*, Fig. 2, and the two bolts are caused to act in conjunction by a pitman, *l*, arranged to cause them to revolve oppositely, to accommodate respectively the right and left jambs, with which they engage.

Referring to Figs. 3 and 4 of the drawings, it will be seen that the disk *A* is secured in the side of the safe, and is provided with a shaft, *K*, having a drive-wheel, *k'*, to engage by pin with gear-wheel *L*. The gear-wheel *L* is secured by bearing *M* to the door *B*, and engages with the geared drive-wheel *F*, which is also secured upon bearing *M*. The operation of the drive-wheel *F* acts to operate or set the combination of the tumblers *I*, and when they are set acts to throw the bolts by engaging with and operating the dog *g*. When the bolt-work has thus been thrown, the door *B* can be swung open without interfering with the disk *A* and shaft *K*, owing to the fact that the drive-wheel *k'* and gear-wheel *L* can readily disengage.

Having thus described my invention, I claim—

1. The rotating disk for manipulating the lock and bolt-work of the safe, composed of a series of stepped welded steel and iron plates, the average diameter of the disk being at least equal to its thickness, substantially as specified.

2. The combination, substantially as specified, of the door, the door-jamb, and the rotating bolt, cut away on one side.

3. In a burglar-proof safe, the combination of rotating bolts *G G' 1 2* and connecting-link *l*, arranged as shown, whereby the bolts may be caused to revolve simultaneously in opposite directions, substantially as and for the purpose specified.

In testimony of which invention I hereunto set my hand this 12th day of December, A. D. 1877.

HENRY GROSS.

Witnesses:

EDGAR J. GROSS,  
W. W. MYERS.