

S. F. PRINCE, Jr.  
Air-Brake.

No. 204,914.

Patented June 18, 1878.

Fig. 1.

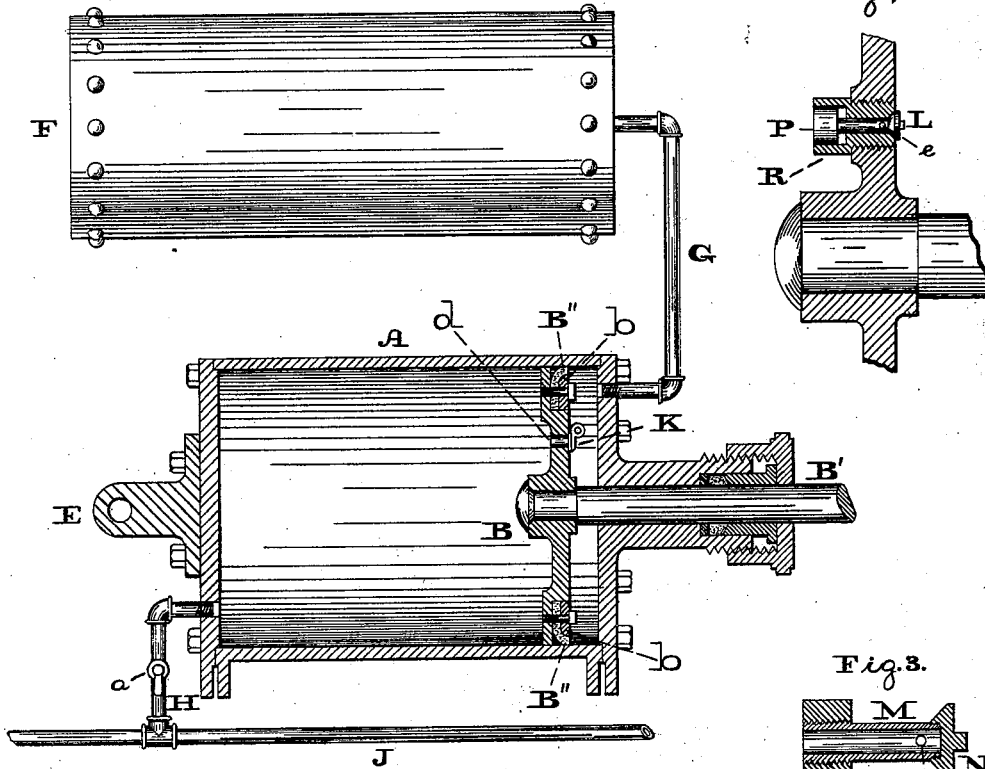
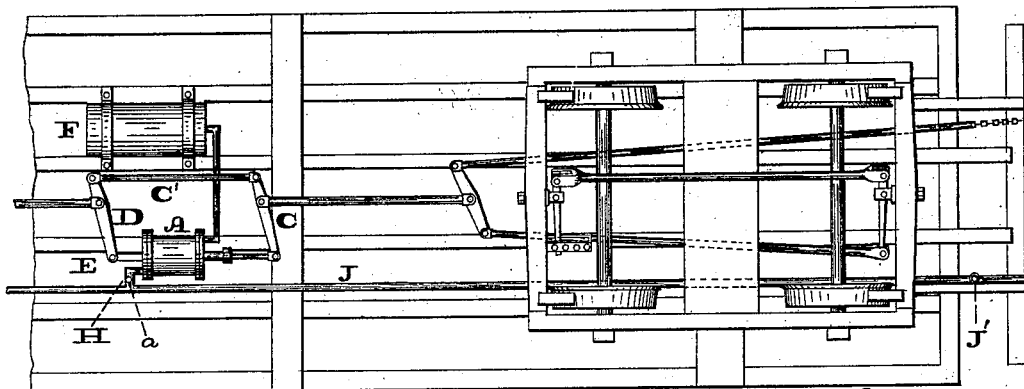

Fig. 2.



Witnesses:

*A. P. Grant,*  
*W. F. Kircher*

Inventor:

*Saml. F. Prince Jr.,*  
by *John A. Diederichs*

ATTORNEY.

# UNITED STATES PATENT OFFICE.

SAMUEL F. PRINCE, JR., OF PHILADELPHIA, PENNSYLVANIA.

## IMPROVEMENT IN AIR-BRAKES.

Specification forming part of Letters Patent No. 204,914, dated June 18, 1878; application filed February 26, 1878.

*To all whom it may concern:*

Be it known that I, SAMUEL F. PRINCE, JR., of the city and county of Philadelphia, and State of Pennsylvania, have invented a new and useful Improvement in Air-Brakes, which improvement is fully set forth in the following specification and accompanying drawings, in which—

Figure 1 is a longitudinal section of the cylinder, and side elevation of the reservoir, of the air-brake embodying my invention. Fig. 2 is a bottom plan of a portion of a car having my invention applied thereto. Figs. 3 and 4 are sectional views of the equilibrium-valve.

Similar letters of reference indicate corresponding parts in the several figures.

My invention relates to that class of air-brakes in which an auxiliary reservoir for compressed air is connected with the brake-cylinder in such manner that pressure may be applied to either side of the piston.

My improvement relates, first, to a novel means of supplying said auxiliary cylinder with compressed air; and it consists in, first, admitting the air into the brake-cylinder, and then through a check-valve in the piston to a pipe which leads from the brake-cylinder to the reservoir, whereby the results hereinafter set forth are attained.

My improvement consists, secondly, in the piston provided with an equilibrium-valve, in combination with pipes leading to the auxiliary reservoir and the main engine-reservoir, all substantially as hereinafter more fully set forth and claimed.

Referring to the drawings, A represents a cylinder, properly attached to the truck of the car, and fitted with a piston, B, whose stem B' is connected to a series of pivoted levers or linkage, C C' D, of which the lever D is pivoted to a lug, E, rigidly attached to or cast with the head of the cylinder, the brake-rods being suitably attached to the levers C D.

F represents an auxiliary air-reservoir, which, properly attached to the body of the car, communicates with the cylinder at the stuffing-box end by means of a pipe, G, and to the opposite end of the cylinder is connected a pipe, H, which is provided with a cock, a, and jointed to a pipe, J, running the length of the train, said pipe J being made continuous by suitable

hose or other connections at the respective ends of the cars, and communicating with the main reservoir on the engine. The piston B has circumferential packing B'', securely held by an annulus, b, or other suitable means; and in the piston is a passage, d, which is opened and closed by a check-valve, K, the character of which depends upon the nature of the pressure in the reservoir on the engine, said valve opening toward the stuffing-box end of the cylinder.

The brake is off when the piston is in the position shown in Fig. 1. The air-pressure is first turned into the pipe J from the main reservoir or engine by means of a suitable cock, a three-way being preferred. The air then enters the cylinder A through the pipe H, and, entering the passage d, thus opening the valve K, it is directed to the pipe G, and reaches the reservoir F, and fills the same until the pressure in it equals that in the main reservoir.

To apply the brake, the air-pressure is withdrawn from the pipe J, and thereby from the end of the cylinder A, to which the pipe H is attached. The pressure in the reservoir F being unable to escape, the check-valve K, closing the passage d, acts upon the piston B and moves it inward, which piston acts upon the linkage C C' D, thereby shortening the distance between the brake-rods which are connected with the ordinary brake-levers, thus applying the brake to the wheels.

To release the brake, the air-pressure is turned into the pipe J from the main reservoir, thence into the cylinder A, until the pressure in the end of said cylinder A at which the air enters from H is equal to that in the reservoir F. The piston B will then move outward, for, as there are equal pressures on each side of the piston which act upon areas differing by the area of the piston-rod upon which the air-pressure cannot act, the total force upon the side of the piston facing the pipe H will be greater than that on the opposite side; consequently the piston will move outward, thereby releasing the brake.

Where the pressure in the main engine-reservoir is subject to variations, (which is usually the case,) while that in the reservoir F is comparatively constant, the piston B is provided with an equilibrium-valve, L, Fig. 2, by means

of which a pressure in the engine-reservoir lower than that in the reservoir F will release the brake. This valve L consists of a hollow stem, M, upon one end of which is fitted a conical valve, N, while the other end is fitted with a piston, P, much larger in area than the valve L, the whole of which is placed in casting R, which is provided with a conical valve-seat at one end, and at the other with a cylinder, in which the piston P moves. The hollow stem M is provided with a small aperture or apertures, e, by means of which, when the valve is open, communication is established between the opposite ends of the cylinder.

When the brake is on, and the pressure in the main reservoir is below that in the reservoir F, the air-pressure, when turned into the cylinder A from the pipe J, acts upon the piston P, which, being larger than the valve L, causes the valve to open, which brings the hole e into communication with the pressure in the reservoir F, by which means the air passes through the valve-stem M until the pressure in both ends of the cylinder A is equalized, by which equalization the brake is released. When the pressure in the main reservoir is constant, any suitable check-valve may be used in the piston B.

The pipe H is provided with a cock, a, by means of which communication between the pipe J and the cylinder A can be closed, should

necessity require it, thus allowing the brakes on the remainder of the train to be used.

When it is desired to uncouple the cars, the escape of air is prevented by closing the cock J' of the pipe J. Should the cars become detached by accident, the air in the pipe J escapes, and the brakes are consequently applied.

If desired, the reservoir F may be combined with the cylinder A by means of an annular cylindrical jacket, which may be cast with the cylinder, and the reservoir F is provided with an exhaust-cock, to exhaust the pressure, if required.

Having thus described my invention, what I claim as new, and desire to secure by Letters Patent, is—

1. In combination with the cylinder A, auxiliary reservoir F, and piston B, the pipes G H and check-valve K of the piston, all arranged to establish communication between pipe H and reservoir F, as herein shown, the said reservoir being supplied with compressed air from cylinder A, substantially as set forth.

2. In an air-brake, the piston B, provided with an equilibrium-valve, in combination with pipes J and G, arranged substantially as and for the purpose set forth.

SAML. F. PRINCE, JR.

Witnesses:

JOHN A. WIEDERSHEIM,  
H. E. GARSEB.