

J. W. THOMPSON & N. HUNT.  
Governor.

No. 204,924.

Patented June 18, 1878.

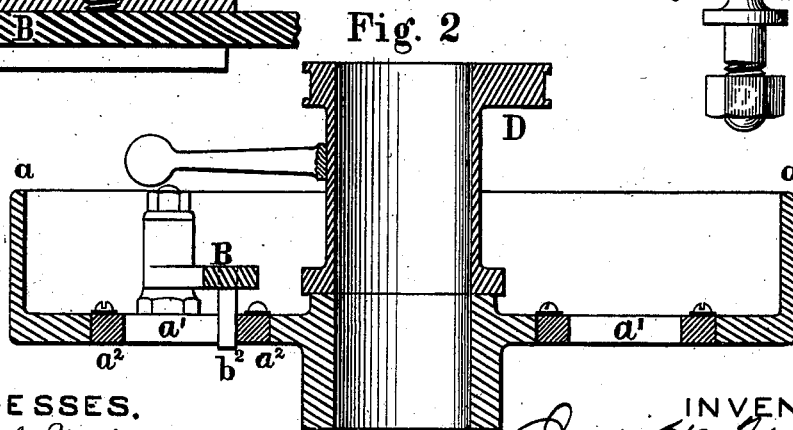
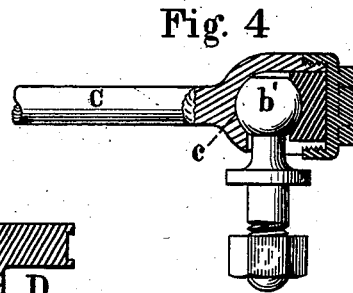
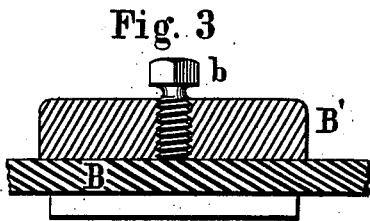
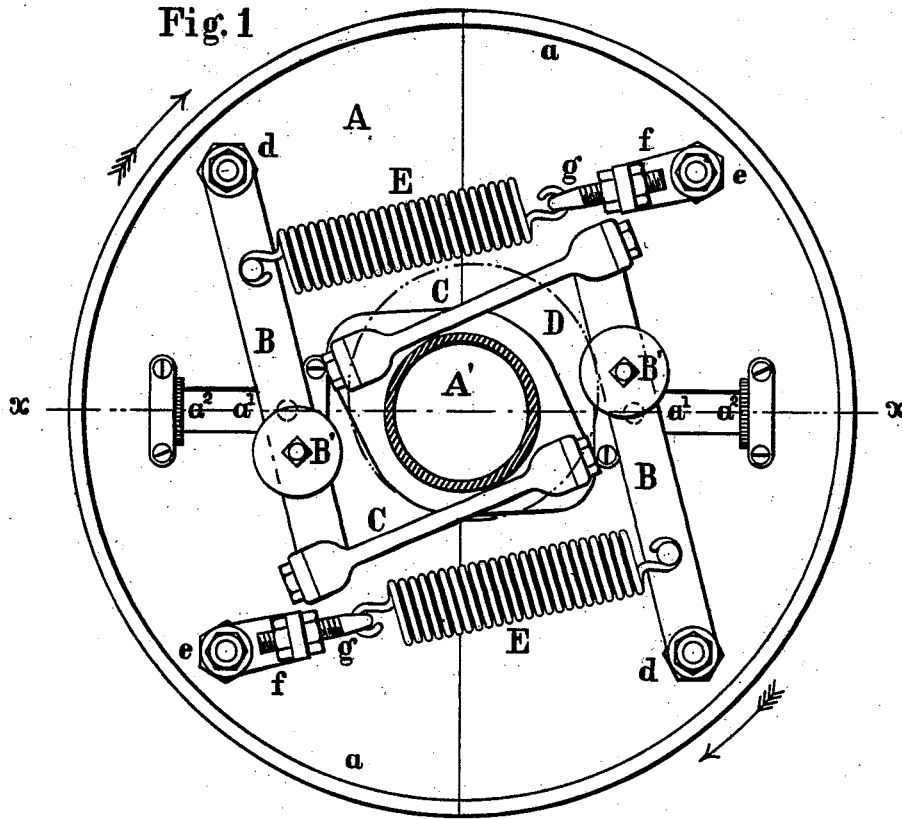

WITNESSES.  
*Geo. A. Vaillant.*  
*Harry O'Neill.*

INVENTORS.  
*Joseph W. Thompson,*  
*Nathan Hunt*  
*by J. Snowden Bell*  
*att'y.*

# UNITED STATES PATENT OFFICE.

JOSEPH W. THOMPSON AND NATHAN HUNT, OF SALEM, OHIO, ASSIGNORS  
OF ONE-HALF THEIR RIGHT TO BUCKEYE ENGINE COMPANY, OF SAME  
PLACE.

## IMPROVEMENT IN GOVERNORS.

Specification forming part of Letters Patent No. **204,924**, dated June 18, 1878; application filed  
May 10, 1878.

*To all whom it may concern:*

Be it known that we, JOSEPH W. THOMPSON and NATHAN HUNT, both of Salem, in the county of Columbiana and State of Ohio, have jointly invented certain new and useful improvements in Steam-Engine Governors, of which the following is a specification:

Our invention relates to that class of centrifugal governors in which the balls or weights rotate with and upon the main or driving shaft of the engine, and operate, by variations of angular velocity, to vary the position of an eccentric thereon relatively to the crank, examples of which class will be found in the Letters Patent of Jacob D. Custer, No. 1,179, dated June 21, 1839, and in Letters Patent No. 162,715, granted to Joseph W. Thompson and the Buckeye Engine Company, (as his assignee,) under date of April 27, 1875.

The improvements herein claimed are intended for application to the governor shown in the patent last above stated; and consist, first, in combining, with the pivoted weight-arms, and the links by which they are connected to the movable eccentric, ball-and-socket joints; and, second, in combining, with the pivoted weight-arms, stop-pins working in slots in the supporting-case between and equidistant from the pins, which form the pivots of the weight-arms on the one side, and from similar pins on the other side, which latter, when the motion of rotation is in the direction shown by the arrows, form the points of attachment for the springs, said stop-pins abutting at either extremity of the traverse of the arms against spring-cushions secured in the ends of said slots, all as hereinafter more fully set forth.

In the accompanying drawings, Figure 1 is a front or face view of a governor embodying our improvements; Fig. 2, a transverse section of the same at the line *x x* of Fig. 1; Fig. 3, a section through one of the weight-arms and its weight, and Fig. 4 a section showing one of the ball-and-socket connections of the weight-arms and eccentric-links.

A case or disk, A, which is firmly secured upon the main or driving shaft A' of the engine, serves for the attachment and support of the mechanism of the governor, said case

being provided with a projecting outer rim or flange, *a*, and being preferably made in two parts, bolted together, for greater convenience in placing it upon and removing it from the shaft. Two weight-arms, B B, are each pivoted at one end to the case A at points diametrically opposite each other, and adjacent to the outer rim, their free ends being connected by links C C to an eccentric, D, which is fitted easily upon the shaft A', and is movable angularly about the center thereof in consonance with the vibrations of the arms about their points of attachment to the case.

A weight, B', having a groove or recess on one side to fit the arm, is mounted on each of the arms B, and is adjustable within a determined range of traverse at any desired point thereon, being secured in its adjusted position by a set-screw, *b*. By this arrangement, desired changes of the speed of the engine may be attained by variations in the position of the weights, the weights being moved out from the pivots of the arms to decrease the speed, and in toward them to increase it.

The requisite centripetal action is provided by spiral springs E E, each of which is connected at one end to one of the weight-arms B, between the weight and the pivot of the arm, and at the other through the intermediation of a device for adjusting its tension to a pin, *e*, on the case A.

In order to insure perfect and easy articulation of the weight-arms B and eccentric-links C under all circumstances, the same are connected by ball-and-socket joints, as clearly shown in Fig. 4, a socket, *c*, being formed in each of the links C, and a ball, *b'*, fitting therein being secured to each of the weight-arms.

For the purpose of relieving the weight-arms and their attachments from shocks due to sudden changes of position consequent upon material variations of load in the engine, each arm B is provided with a stop-pin, *b''*, projecting into and traversing in a slot, *a'*, formed in the case A, and abutting, when the arm is at the extremity of its oscillatory traverse in either direction, against a rubber or other spring-cushion, *a''*, which cushions are fitted into the slots *a'* at each of their ends, and

serve to receive and relieve the impact of the pin against the case.

The slots being, as before stated, midway between the pins *d d*, on which the levers *B B* are pivoted, and the pins *e e*, on which the dogs *f f* (through which the tension-screws *g g* pass) are fitted, the relative positions of the levers and dogs can be reversed by placing the levers on the pins occupied by the dogs, and the dogs on those occupied by the levers, and the slots with their spring-cushions will be in the proper position for the stop-pins *b<sup>2</sup>*, as before. When such change has been made, the parts will be in the proper position for a direction of motion opposite to that indicated by the arrows.

The general principles of construction of the governor which we have herein described and shown are similar to those of the governor shown in Patent No. 162,715, hereinbefore referred to, upon which our present invention is an improvement; and while we have for greater perspicuity fully set forth such construction herein, we do not here broadly claim the same, restricting ourselves to the improvements thereon specifically above described.

We claim as our invention and desire to secure by Letters Patent—

1. The combination, with a steam-engine governor adapted to be mounted upon the driving-shaft, of a loose eccentric fitting upon the shaft and connected to the weight-arms of the governor by links, united with said arms by ball-and-socket joints, substantially as set forth.

2. The combination, in a steam-engine governor adapted to be mounted upon the driving-shaft, of a supporting-case, weight-arms pivoted to said case, and stop-pins secured to the weight-arms and projecting into radial slots in the case, which are provided with spring-cushions at their ends to act as abutments for the stop-pins, substantially as set forth, the construction being such that the slots and spring-cushions are in proper position for both directions of rotation.

JOSEPH W. THOMPSON.  
NATHAN HUNT.

Attest:

J. S. BONSALE,  
JOEL SHARP.