

S. H. GILMAN.
Bale-Tie.

No. 204,965.

Patented June 18, 1878.

Fig 1.

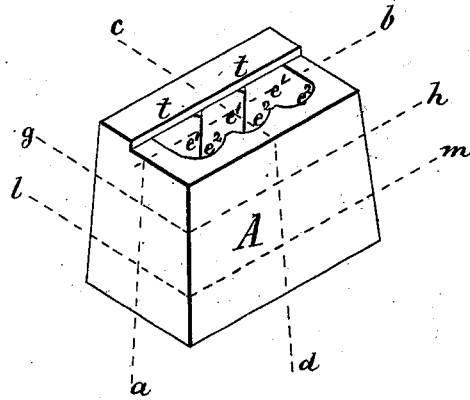

Fig 2.

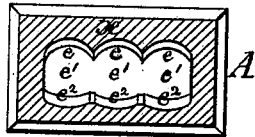

Fig 3.

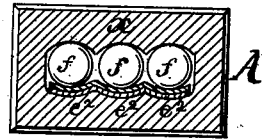

Fig 4.

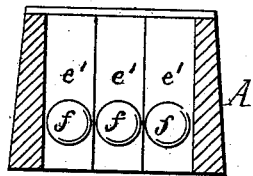
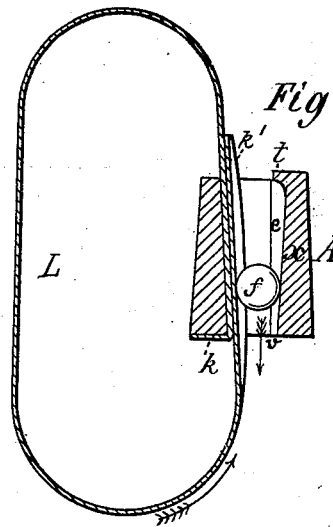

Fig 5.



Witnesses:

J. P. Theodore Lang
Auguste Perry

Inventor:

Samuel H. Gilman
by
Mason, Hammett & Lawrence

UNITED STATES PATENT OFFICE.

SAMUEL H. GILMAN, OF NEW ORLEANS, LOUISIANA.

IMPROVEMENT IN BALE-TIES.

Specification forming part of Letters Patent No. **204,965**, dated June 18, 1878; application filed May 23, 1878.

To all whom it may concern:

Be it known that I, SAMUEL H. GILMAN, of the city of New Orleans, parish of Orleans, and State of Louisiana, have invented a new and useful Improvement in Bale-Ties, which improvement is fully set forth in the following specification and accompanying drawings, in which latter—

Figure 1 is a perspective view of my improved bale-tie, which bale-tie has a capacity for a band-strain of three thousand pounds. Fig. 2 is a horizontal section in the lines $g h$ of Fig. 1, without the metallic globes f and band L, used in effecting the tie. Fig. 3 is a horizontal section in the lines $l m$ of Fig. 1, with the globes f in plan view and band L in section, as when perfectly fastened. Fig. 4 is a vertical section in the lines $a b$ of Fig. 1, with the globes f in elevation. Fig. 5 is a vertical section in the lines $c d$ of Fig. 1, with a globe, f , in elevation, and an entire band in section, as when perfectly fastened.

The exterior form of my bale-tie is a parallelogram in horizontal, and of pyramidal form in vertical, section, and its interior is in the general form of cone-shaped channels, which communicate with each other throughout their length, as indicated in Figs. 1, 2, and 3.

Both sides of the interior of the bale-tie A are corrugated, as at $e e^2$, so as to form three intermediate divisions, e^1 , for the reception of the metal globes f ; or there may be more or less of these divisions e^1 , if desired, and a corresponding greater or less number of globes f . The interior corrugations e on the front side x of the bale-tie A are for the purpose of keeping the globes f separated, and for securing a more equal distribution of their pressure on the width of the band L. The interior corrugations e^2 on the back side of the bale-tie are for the purpose of increasing the friction between the ends of the band L and the back side of the bale-tie, as well as between the ends themselves of the band, the friction of these surfaces constituting the holding-power of the tie.

The raised points of the corrugations e are parallel to each other, and of such distance apart, and with a depth of the divisions e^1 such, that when the globes f are within the bale-tie, and the end k of the bale-band in-

serted, as indicated in Fig. 5, none of the globes f can pass out of its own division e^1 into another.

A lip, as at t , at the front end of the bale-tie, is made to project over and cover a portion of the front ends of the divisions or channels e^1 , at which point said divisions are of greatest depth or capacity, said divisions being constructed tapering from the front end of the tie, where they are of greatest capacity, to the rear end or base v of the tie, where they are of the least depth or capacity. This lip t is made to cover so much of the front ends of said divisions that when the globes f are in place in their respective divisions e^1 , and the end k of the band L inserted, none of the globes can escape from the interior of the bale-tie, either in front or rear, nor change places with each other. The globes f and one end k of the bale-band having been thus inserted, the bale-tie is then complete, and ready either for immediate use or for transportation, as may be desired.

When it is desired to apply it to a bale, as indicated in Fig. 5, the opposite end k' of the band is pushed upward through the bale-tie from the bottom or base v , thus rolling the globes f along the widened portions of the cone-shaped divisions e^1 toward the lip t , until the full desired strain is attained, whereupon the slightest reverse movement of the end k' of the band L will roll the globes down the divisions e^1 , thus pressing both ends of the band into the corrugations e^2 , as indicated in Fig. 3, until the friction is greater than the strain, and thus effectually tie the bale-band around the bale.

I would here state that in the operation of tying a bale the friction of the stationary or fixed end k of the band, being upon both of its flat sides, is double that of the movable end k' , one side of which is only pressed by the rolling globes, from which, practically, there is no great friction, so that with equal strain on the two ends of the band L the end k' only can slip in the tie A. Hence, in practice, the end k need not necessarily be bent over the tie, as shown in Fig. 5.

It will be seen that by constructing my tie with channels e^1 , I am enabled to more effectually distribute the bite of the globes f over

the width of the bale-band, and at the same time utilize very small globes for such purpose, which enables me to make the body of the tie flat or of small vertical diameter, which is desirable in view of the handling of a bale.

I am aware of Letters Patent No. 28,187, and therefore do not claim a tie plate or body with a single tapering channel or chamber, at one end of which is a detaining-lip, and such chamber being adapted only for a single globe or ball.

I claim—

1. A bale-tie provided with two or more sets of corrugations, e and e^2 , in combination with globes f and bale-band L , whereby a band as broad, or nearly so, as the channels formed

by the corrugations may be passed through the body of the tie, and several independent globes employed to bear on said band without liability of moving laterally out of one channel into another, substantially as described.

2. The body A of a bale-tie, constructed substantially as described, in combination with globes f and a bale-band, L , for the purposes set forth.

Witness my hand in matter of my application for a patent for improvement in bale-ties.

SAMUEL H. GILMAN.

Witnesses:

ANDREW HERO, Jr.,
FRANCIS GRAHAM.