

W. H. PLUMB.
Ore-Jigger.

No. 204,996.

Patented June 18, 1878.

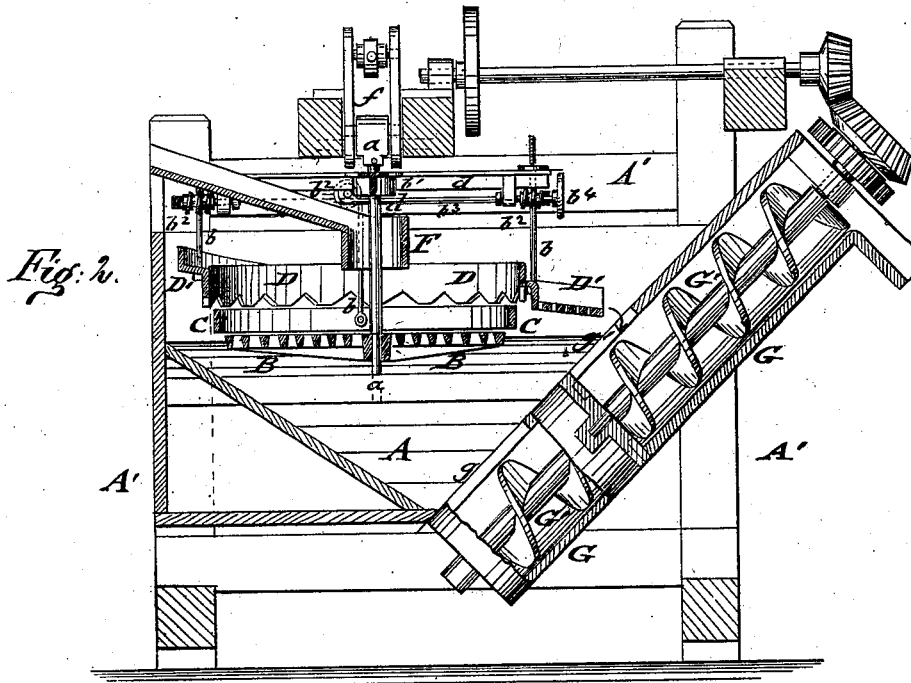
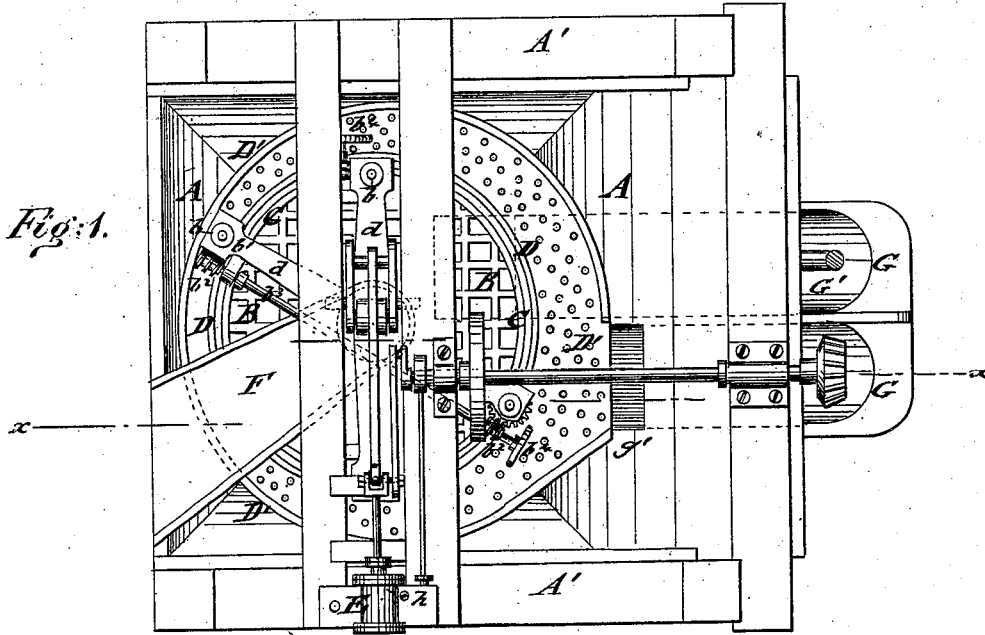

WITNESSES:

Chas. A. A. A.
J. H. Scarborough.

Fig. 3.

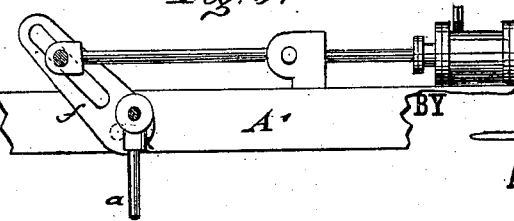

INVENTOR:

W. H. Plumb

Mumford

ATTORNEYS.

UNITED STATES PATENT OFFICE.

WILLIAM H. PLUMB, OF MAUCH CHUNK, PENNSYLVANIA, ASSIGNOR TO
JOSEPH A. STERLING, OF NEW YORK CITY.

IMPROVEMENT IN ORE-JIGGERS.

Specification forming part of Letters Patent No. **204,996**, dated June 18, 1878; application filed August 18, 1877.

To all whom it may concern:

Be it known that I, WILLIAM H. PLUMB, of Mauch Chunk, in the county of Carbon and State of Pennsylvania, have invented a new and Improved Jigger for Separating Ores, of which the following is a specification:

In the accompanying drawing, Figure 1 represents a plan view; Fig. 2, a vertical longitudinal section on line *x x*, Fig. 1, of my improved jigger for separating ores; and Fig. 3 is a detail side view, showing the connection of the central supporting stem or rod of the jigger with the operating motor.

Similar letters of reference indicate corresponding parts.

The object of this invention is to so improve the apparatus or jigger for separating ores from slate and other lighter products for which Letters Patent have been granted to me under date of July 1, 1873, and No. 140,535, that the lighter parts are separated from the heavier parts, and discharged separately from the same in a superior manner; and the invention consists of a vibrating grate, with a vertically-adjustable and encircling curbing, and a vertically-adjustable ring with level top, encircling inclined chute, and scalloped or recessed lower edge placed above the curbing and grate, the grate, curbing, and ring being suspended from a center rod or stem and horizontal cross-bars, and vertically vibrated by an eccentric pivot-connection with an oscillating crank-arm, operated by a steam-engine or other motor.

The jigger is placed in a tank with inclined bottom and discharge-opening, communicating with a casing and revolving discharge-spiral, while the inclined chute of the ring connects with a second aperture of the tank and separate casing and shorter spiral, to discharge the lighter products independently of the heavier ores.

In the drawing, A represents the tank of my improved jigger for separating ores, said tank being supported on a suitable frame, A', and provided with a bottom, having inclined or hopper-shaped sides. At the interior of the tank A is suspended from a center shaft or stem a flat or slightly-conical grate, B, with perforations smaller than the products to be

separated, so as to prevent their direct passage through the grate into the tank.

The grate is vertically reciprocated or vibrated by suitable power, and bounded or encircled by a curbing, C, that extends more or less above the level of the grate B. The curbing C is suspended on vertical screw-rods *b*, which are hung to a horizontal cross-bar, *d*, secured to the center stem or shaft, the rods carrying fixed pinions *b*¹, into which mesh worms *b*² of a cross-shaft, *b*³, with end hand-wheel *b*⁴, for the purpose of admitting the convenient vertical adjustment of the curbing C to the grate.

The object of the adjustment is to retain a greater or less depth of the heavier particles that are to be separated from the lighter products, according to the varying specific gravities and quantity of the same.

A ring, D, of larger inside diameter than the outside diameter of the curbing C, is suspended in similar manner by screw-rods *b* from a second cross-bar, *d*, and adjusted also by pinions and intermeshing worm-gear as to height or distance from the curbing and grate. The ring D leaves a space of certain width around the curbing, and is made with a level top and with a toothed, scalloped, or otherwise recessed bottom edge. An inclined perforated and rimmed chute, D', extends around the outside of the ring D, and serves to discharge the lighter products that are passed over the top of the ring D.

The grate B, curbing C, and ring D are jointly and simultaneously vibrated by the center rod *a*, which receives motion from an oscillating crank-arm, *f*, to which the rod *a* is eccentrically pivoted. The crank-arm *f* is slotted, so as to vary the stroke of the jigger by shifting the pin of the connecting lever-rod of the steam-engine or other motor, E, which is supported either on the top of main frame A' or in proximity to the jigger. The tank A is filled with water up to a level that will admit of little or no escape of water in discharging the separated products. A quick and short vibration is given to the jigger, to which the ore or other material to be separated is fed by a hopper, F, at the center. The heavier parts settle on the vibrating grate

B, and accumulate thereon to the height of the top of the curbing C, the vibratory motion of the grate causing the water to flow quickly through the perforations of the same, so as to act with considerable force on the ore, and suspend and carry over the top of the ring D the lighter products, which are conveyed off by means of the inclined chute D'. The excess of heavier products is discharged over the curbing C, and passed between the same and the lower serrated edge of the ring D into the tank, the serrated or scalloped edge admitting the passage of pieces larger than the average size without requiring the ring to be raised too high.

The bottom of the tank is made of inclined surfaces, or hopper-shaped, one surface having a discharge-opening, *g*, near the lowermost point of the bottom, and a second discharge-opening, *g'*, above the same, below the spout of the inclined chute D'. The discharge-openings *g g'* communicate with an inclined double casing, G, and with revolving spirals G' of different length, of which the longer takes up the heavier pieces from the bottom of the tank, while the shorter takes up the lighter products passing over the inclined chute D'.

The spirals G' are revolved by suitable gearing in connection with the driving-power and the casings G, separated by a suitable parti-

tion, which extends beyond to upper ends of the casings, to separate the spouts of the casing, and thereby produce the separate discharge of the lighter and heavier products. The spirals revolve at the required velocity to suit the quantities to be discharged.

The relative adjustment of curbing and ring to each other and the grate renders the jigger capable of working ores of any quantity, size, and specific gravity, separating and washing the heavy parts from the slate and other light particles in effective, quick, and economical manner.

Having thus described my invention, I claim as new and desire to secure by Letters Patent—

1. The combination, with the vibrating grate and circumjacent vertically-adjustable curbing, of the vertically-adjustable ring, made with a beveled top edge and outer inclined chute, as and for the purpose described.

2. The combination of the grate B, curbing C, and ring D, having chute D', of the two unequal spiral conveyers, working side by side in double case, and having inlets *g g'* at different levels, as and for the purpose specified.

WILLIAM H. PLUMB.

Witnesses:

C. SEDGWICK,
PAUL GOEPEL.