

D. HARRIS.
Machine for Making Button-Hole Linings.

No. 205,080.

Patented June 18, 1878.

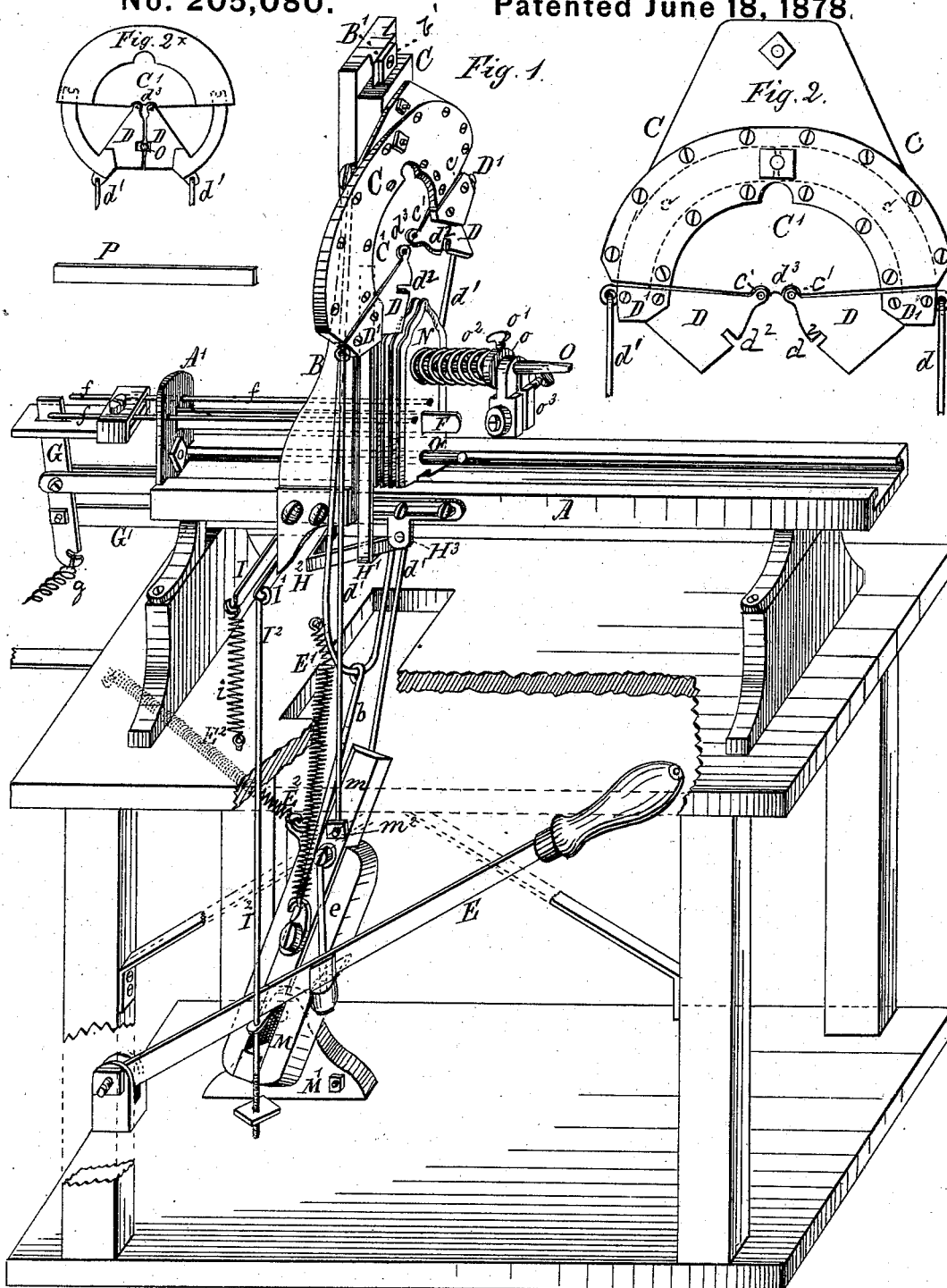

Witnesses
Henry Orth
W. H. Bliss

Inventor
David Harris
J. H. Doubleday
att'y

D. HARRIS.
Machine for Making Button-Hole Linings.

No. 205,080.

Patented June 18, 1878.

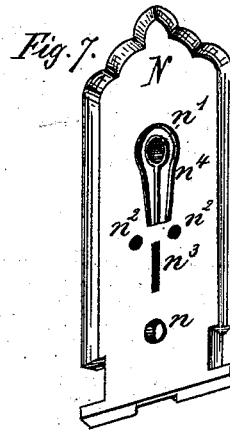
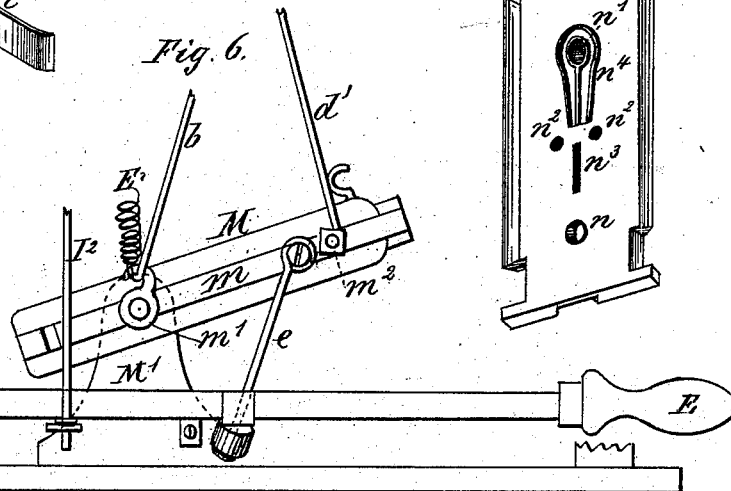
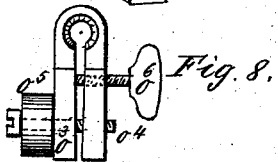
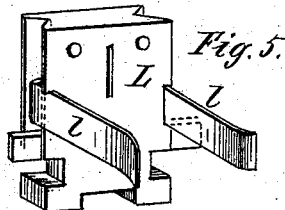
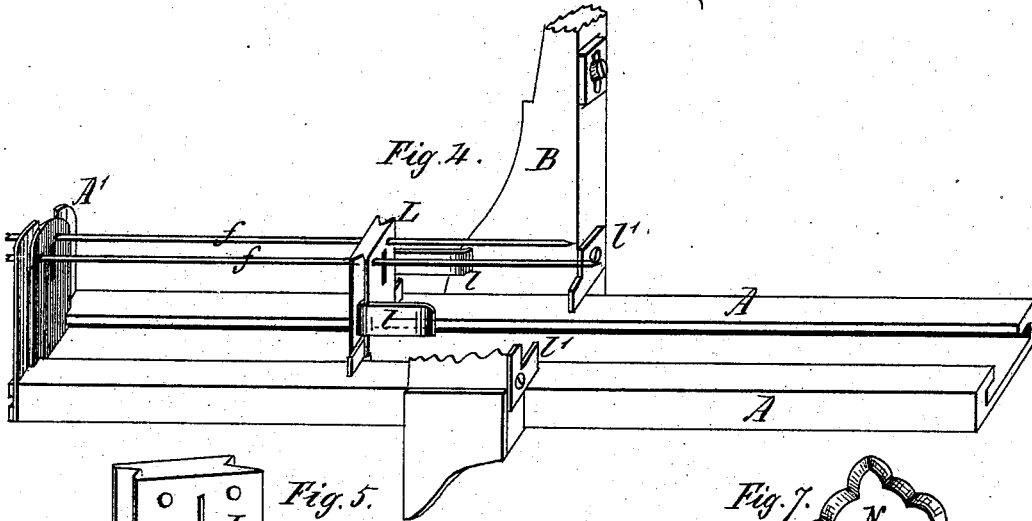
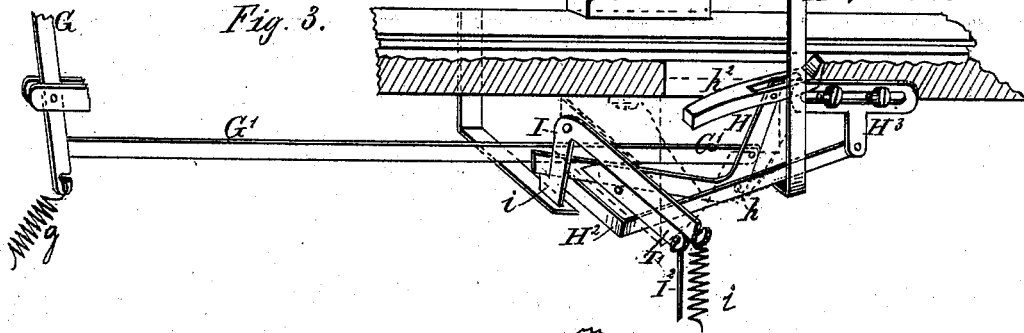

Witnesses
Henry Orth
H. H. Bliss

Inventor
David Harris
H. H. Doubleday
atly.

D. HARRIS.
Machine for Making Button-Hole Linings.
No. 205,080. Patented June 18, 1878.

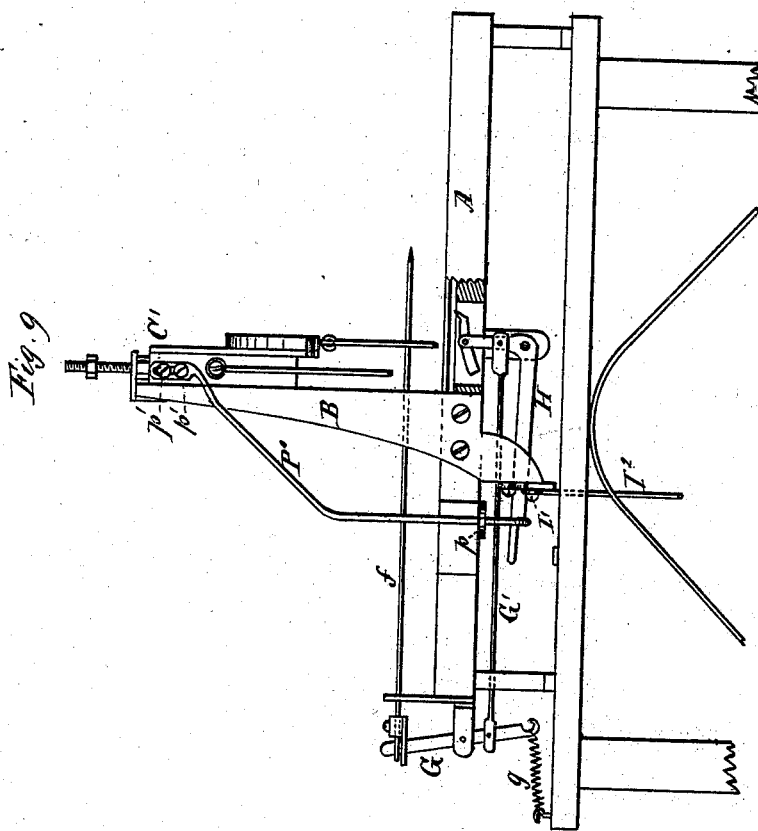

Witnesses.
Henry Orth
H. A. Bliss

Inventor.
David Harris
per H. A. Doubleday
att'y.

UNITED STATES PATENT OFFICE.

DAVID HARRIS, OF BROOKLYN, NEW YORK, ASSIGNOR OF ONE-HALF HIS
RIGHT TO JOHN G. COZINE, OF SAME PLACE.

IMPROVEMENT IN MACHINES FOR MAKING BUTTON-HOLE LININGS.

Specification forming part of Letters Patent No. **205,080**, dated June 18, 1878; application filed
September 17, 1877.

To all whom it may concern:

Be it known that I, DAVID HARRIS, of Brooklyn, in the county of Kings and State of New York, have invented a new and useful Improvement in Machines for Making Button-Hole Linings from Leather or other suitable Material, which improvement is fully set forth in the following specification and accompanying drawing, in which—

Figure 1 is a perspective view of my improved machine. Fig. 2 is a detached view of the crimping-plate and crimpers. Fig. 2* is a detached view, reduced, of the crimping-plate and crimpers. Figs. 3, 4, 5, and 6 are detached views of various operative parts of the mechanism. Fig. 7 represents one of the crimping and embossing plates or dies. Fig. 8 is a tension device. Fig. 9 is a side elevation, partly in section, of so much of my machine as is necessary to represent a modification of the means employed for actuating, in part, the feeding mechanism.

A is the bed-frame, consisting of two sills or ways fitted with grooves or with V-shaped ribs, in which or upon which slide certain devices, to be hereinafter explained.

B B' is the upright portion of the frame, of which B' is a guiding dovetailed rib. C is a sliding carrier, provided with a dovetailed groove, fitting accurately the rib B', and actuated by link *b* and a foot-treadle. C' is a crimping-plate, attached to the front of the carrier and reciprocating with it. This plate has upon each side recesses *c* in arcs of circles, (of which the two points *c'* are the centers, respectively,) as indicated by dotted lines in Fig. 2.

D D are crimping-plates, attached to the segmental carriers D' D', which are mounted in the segmental recesses *c* in plate C'. The crimping-plates are actuated by means of links *d' d'*, operated by a treadle, E. The lower end of the crimper may be notched to engage with opposite sides of the bed-frame, and thus limit their downward and inward throw.

*d*² are notches in the inner faces of the crimpers to receive needles, for a purpose which will be soon explained, and their upper corners are formed into circular ears *e' e'*,

which enter correspondingly-shaped seats cut in the central part of a downward extension of the plate C'.

In Fig. 2* a circular opening, *d*², is shown, formed partly in this last-mentioned plate and partly in the upper corner of the crimpers. F is a centering-tongue, attached to the standard A' at the rear end of the frame. *f f* are needles passing through the standard A', and connected at their rear ends to the upper end of a lever, G, which is pivoted to the bed-frame or to an arm extending rearward therefrom.

G is a link, connecting the lower end of lever G with the upper end of a bell-crank lever, H, which is pivoted at *h* to a bracket depending from the under side of the bed-frame. H² is a bail or hook, the legs of which are pivoted in sliding carriers H³, which are adjustably attached to both sides of the bed-frame by means of a slot and set-screw, one carrier only being shown in Fig. 1. The closed end of the bail or hook is arranged below the free end of the horizontal arm of the bell-crank arm H. A strap or loop, H¹, attached to the carrier C, lifts the bail H², as will be explained. *h*² is a weighted feeding-dog, pivoted to the upper end of the vertical arm of the bell-crank lever H.

I is a locking-lever, pivoted in a suitable support at the under side of the bed-frame, in such position that the rear end of the horizontal arm of the bell-crank lever may rest upon a spur or tooth, *i*, of the locking-lever when it is desired that the needles *f f* shall be retracted to the position shown in Fig. 1. *g* is a spring, connected with lever G, to thrust the needles forward when the bell-crank lever is released from the locking-lever I.

Any other form of spring than that shown may be employed for this purpose; or a spring may be applied to the bell-crank lever H and accomplish the same result.

I¹ is a tripping-lever, operated by link I² from the foot-treadle E; and *v* is a spring to hold the locking-lever I in engagement with the bell-crank lever, except when said locking-lever has been tripped. Link I² is provided at the lower end with a screw-nut, to regulate

the point at which the foot-treadle in its downward movement shall trip the locking-lever.

In Fig. 9 I have shown a modification of the means employed in lifting the rear end of the bell-crank lever H, as follows: P' is a link, having its upper end slotted, and adjustably secured to the carrier C' by means of screws $p' p'$, passing through the slot. The lower end of link or lifting-rod P' is bent inward at a right angle, and extends transversely of the bed-plate A below the rear end of the bell-crank lever H. p is a guiding-plate or bracket, secured to the bed-plate, and provided with a hole, through which the link P' passes, thus serving as a guide for the lower part of the link.

From the above it will be readily understood that the upward movement of the carrier and link P' lifts the rear end of the bell-crank lever H into the position shown in Fig. 9, and that the height to which the link thus lifts the lever relative to the height or point at which the carrier rises may be regulated by means of the screws $p' p'$ and the slot in the upper end of the link.

L is a guide, sliding upon the bed-frame, and provided with openings, through which the needles $f f$ and the centering-tongue pass. $l l$ are elastic arms projecting forward from guide L. $U U$ are stops secured to the frame-work, and projecting inwardly into the path of the guide L, to limit the forward movement of the guide. M is an arm, pivoted to a standard, M', and provided with a dovetailed groove, in which a bar, m , slides. The link b , which actuates the carrier C, is attached to the lower part of this bar at m^1 , and the links $d' d'$ are attached at their lower ends to a pivot, m^2 , near the upper end, a link, e , connecting the bar with the treadle E.

In Fig. 7 I have shown detached one of the forms or die between which the button-hole linings are crimped or molded, and in Fig. 1 the dies are represented properly set up in working position. N N are the dies. Their edges are beveled at top and sides, so that when placed side by side there is a groove between each pair. They are provided, near their lower ends, with recesses to fit upon the ways A A of the bed-plate, and with two holes, $n n^1$, for the insertion of supporting-rods O O'. They have also each two smaller holes, $n^2 n^2$, to receive the needles $f f$, and a slot, n^3 , through which the guiding-tongue F passes. One side of each plate is flat; but the other side has centrally an embossing-depression, n^4 .

Rod O has a nut at one end, and carries at the other end of the string of dies a tension or pressure device, as follows: o is a washer, having a set-screw, o^1 , in one side. o^2 is a spiral spring, arranged between washer o and the last die of the series. o^3 is a tension-loop, clasping rod O, the desired friction of the loop upon the rod being produced by means of the set-screw o^4 and spring o^5 at the outer ends of the legs of the loop. o^6 is a set-screw, passing

through one leg and impinging upon the other leg.

This device is operated as follows: After the series of dies have been placed on the rods, the spring o^2 is placed against the last one and compressed by the washer o , which is then fastened temporarily by set-screw o^1 . The legs of loop o^3 are then spread apart by set-screw o^4 until the loop can be easily pushed to the position shown in Fig. 1, and the set-screw o^6 turned backward until the loop is held to the rod by the full pressure of the spring o^5 . The set-screw o^1 is next turned backward, permitting pressure of spiral spring o^2 to be exerted upon the tension-loop, when, if the tension of the spiral spring has been too great, it will be at once relieved by pushing the tension-loop from the dies until the friction of the loop upon the rod stops it.

The operation of my machine is substantially as follows: Supposing the parts to be in the position shown in Fig. 1, the rear end of bell-crank lever H is supported upon the locking-lever I, and the needles $f f$ are withdrawn from the path of the crimpers. A blank, P, is placed transversely of the series of dies. A downward movement of the treadle forces the plate C' and the crimpers D D upon the blank, and presses it (the blank) between two of the dies, the groove facilitating the proper shaping of the blank. This downward movement is continued until the sliding bar m reaches the bottom of the groove in the arm M and the pivot m^1 is on a line coincident with the pivot about which the arm M vibrates, when the downward movement of the carrier C and crimping-plate c' ceases; but a further depression of the treadle causes the arm M to swing forward upon its pivot, as in Fig. 6, and thus, through the links $d^1 d^1$, to close the crimpers D D into the position shown in Fig. 2* and complete the formation of the button-hole lining. Just before the downward motion of the treadle ceases, the link P' trips the locking-lever I, when the spring g and lever G thrust the needles $f f$ through the notches $d^2 d^2$ and the lower ends of the button-hole lining, so that when the treadle is released and lifted by springs E¹ E² the outward and upward movement of the crimpers shall not remove the lining from its position between the dies.

As the carrier goes up the loop H¹ and bail H² lift the rear end of the bell-crank lever and hang it upon the locking-lever I, and the forward movement which is thus imparted to the feeding-dog h^2 thrusts the series of dies forward the thickness of one die and the interposed crimped lining to receive another blank; and it will be readily understood that the length of the upward throw of the closed end of bail H², and consequently the forward throw of the feeding-dog h^2 , can be regulated at will by moving the adjustable carriers H³ backward or forward. Thus at each rising-and-falling movement of the crimping-plates

and their carrier an automatic intermitting feeding of the dies is effected to receive a new blank. By the same movement the needles *f f* are withdrawn into the position shown in Fig. 1, and the parts are ready to repeat the above-described operation.

It will, of course, be understood that the blanks are to be in proper temper; and it will be seen that, as each blank is forced in between a pair of dies, the tension devices will yield to receive it, and this constant pressure, which is applied at a point opposite to the embossing-depression *n⁴*, forms upon one side of each lining a raised rib or bead, which is not only ornamental, but also serves as a guide by which to properly insert the lining in the button-fly of a shoe or other article.

I am aware that male and female dies, or their equivalents, have been employed for embossing or otherwise producing a raised figure or design upon leather by means of a sufficient pressure being employed to strike up, practically instantaneously, the desired impression; but to do this in my machine would require a complicated mechanism, because the crimpers separate my dies some distance, and they (the dies) are advanced upon the bed-frame to receive each new blank; and it will be readily seen that a device which would suddenly strike up a bead upon each newly-crimped lining would require many adjustments to meet the constantly-varying conditions or positions of the dies. Hence I have adopted the plan of producing the bead by means of a continuous pressure, which forms it (the bead) after the crimpers have been withdrawn from between the dies, and by a continuous pressures produced by the spring *o²*.

Under some circumstances I may dispense with the guiding-tongue *F* and change the form or position of the rod *O⁴* to better retain the dies in position. The upward throw of the carrier-plate *C* is limited by an adjustable stop, *b¹*.

It will be seen that the short section of rod *O* between each pair of dies serves, in combination with the opening *d³*, to form the eye of the lining.

What I claim is—

1. In a machine for making button-hole linings, the combination, with the dies *N* and rod *O*, of the vibrating crimpers *D D*, substantially as set forth.

2. The vibrating crimpers, in combination with the segmental carrier *d¹ d¹*, substantially as set forth.

3. The combination, with the carrier *C* and crimpers *D D*, of the treadle *E*, arm *M*, sliding bar *m*, and connecting-link, substantially as set forth.

4. The combination, with the crimpers and dies, of the needles *f f*, substantially as set forth.

5. The combination, with the needles, of the guide *L*, substantially as set forth.

6. In a machine for making button-hole linings, the combination, with the series of dies *N*, of the guide *L*, provided with elastic fingers *l l* and the stops *v v*, substantially as set forth.

7. The combination, in a machine for making button-hole linings, with the needles *f f*, of the lever *G*, link *G¹*, the bell-crank lever *H*, and the locking-lever *I*, substantially as set forth.

8. The combination, in a machine for making button-hole linings, with the locking-lever and the bell-crank lever, of the tripping-lever *I¹*, link *I²*, and the treadle *E*, substantially as set forth.

9. The combination, with the needles, of the spring *g*, adapted to thrust them into the lining, substantially as set forth.

10. The dies *N*, provided at their lower ends with recesses, and arranged in a series, substantially as shown, whereby the recesses form continuous grooves adapted to fit upon the ways *A*, as set forth.

11. In a machine for making button-hole linings, the combination, with the dies *N*, provided with the embossing-recesses *n⁴*, of crimpers which force the blank between the dies, and a spring which presses the dies toward each other after the lining has been crimped, and thereby raise the bead, substantially as set forth.

12. The dies *N*, in combination with rod *O* and a tension device, to maintain pressure upon the dies, substantially as set forth.

13. The combination, with the ways *A A* and dies *N*, of an automatic feeding device for said dies, substantially as set forth.

DAVID HARRIS.

Witnesses:

JOHN G. COZINE,
H. H. DOUBLEDAY.