

O. COOLEY.
Harvester-Rake.

No. 205,175.

Patented June 25, 1878.

Fig. 1.

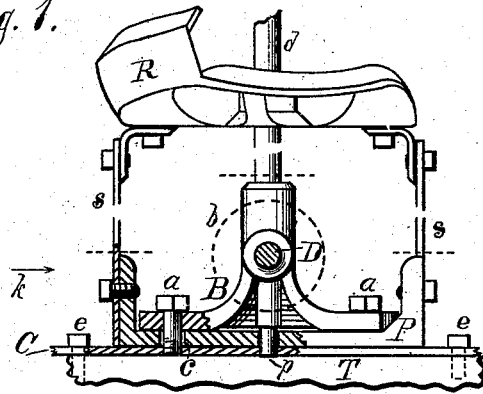

Fig. 2.

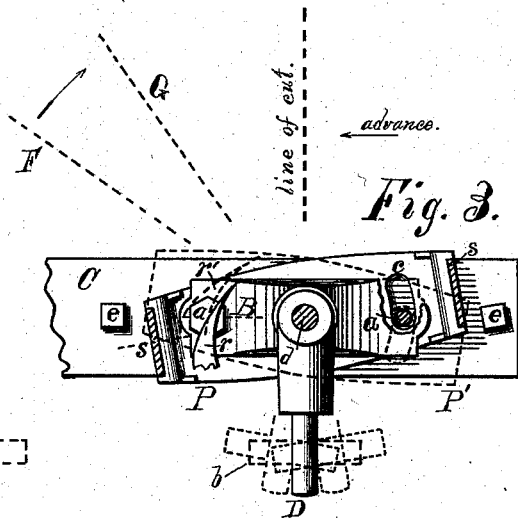
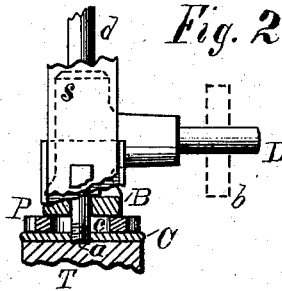

Fig. 4.

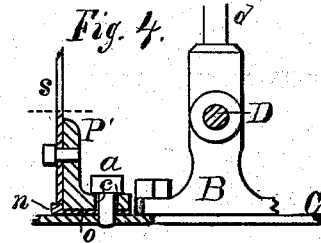
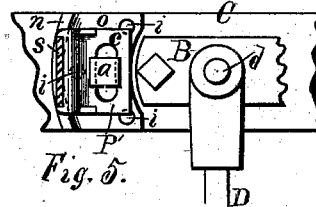

Fig. 5.



Attest:
Louis C. Cook,
John W. Burns,

Inventor:
Orville Cooley,
by E. B. Whitmore, Atty.

UNITED STATES PATENT OFFICE.

ORVILLE COOLEY, OF BROCKPORT, NEW YORK, ASSIGNOR TO JOHNSTON HARVESTER COMPANY, OF SAME PLACE.

IMPROVEMENT IN HARVESTER-RAKES.

Specification forming part of Letters Patent No. **205,175**, dated June 25, 1878; application filed January 15, 1877.

To all whom it may concern:

Be it known that I, ORVILLE COOLEY, of Brockport, in the county of Monroe and State of New York, have invented a new and Improved Support for the Rake-Cam of a Grain-Harvester; and I do hereby declare the following to be a full and exact description of the same, reference being had to the accompanying drawings, forming part of this specification, in which—

Figure 1 is a side elevation of my improved rake-cam support, partly in section. Fig. 2 is an end elevation, also partly in section. Fig. 3 is a plan view, partly in section, showing different positions of the support by dotted lines. Fig. 4 is a side elevation of a modified form of the support, partly in section; and Fig. 5 is a plan view of the same, parts being broken away.

Similar letters of reference in the several figures denote the same parts.

My invention relates to that class of grain-harvesters in which sweep-rakes are employed and guided upon an elevated cam-track; and it has for its object to adjust the cam-track for the purpose of regulating the working position of the rakes without throwing the driving mechanism of the rake-shaft out of line.

To this end the invention consists in the means employed for adapting the cam-track and its standard to be turned laterally without changing the position of the gearing which drives the rakes, as I will now proceed to describe.

In the accompanying drawings, O T represent that part of the machine which supports the cam-track and its attachments. P is a cast-metal base-plate resting upon the part C, and having upturned ends for the support of the standards *s s*, which carry the cam-track R, said standards being countersunk in the outer faces of such upturned ends, as shown.

B is a cast-metal bearing-block, having a central bottom stud, *p*, stepped in the base-plate, so that the latter can turn freely thereon when necessary. It is also formed with a bearing in its upper end to receive the rake-shaft *d* and a lateral bearing for the driving-shaft D. The ends of this bearing-block are cast with holes, through which bolts *a a* are

passed into the curved slots *cc* of the base-plate, as shown, for the purpose of locking the two together in any required position within the limits of the slots.

The adjustments of the base-plate P and the cam-track will be clearly understood by reference to Fig. 3. In this figure the full lines show the position of the base-plate for holding the cam-track so that the rakes shall descend into the grain with reference to the line of cut at about the dotted line F, while the dotted lines of the base-plate show the position it occupies for setting the cam to carry the rakes into the grain substantially at the dotted line G. The rakes, of course, are lifted from the platform at a point relatively earlier or later, accordingly as they are caused to descend into the grain earlier or later.

Heretofore, in this class of machines, the standard of the rake-shaft has been forced to turn with the cam-track in adjusting its position, which caused the sprocket-wheel *b* to be thrown out of line with the driving-sprocket A, (shown by dotted lines,) and seriously strain or slacken the driving-chain connecting them, as will be readily appreciated by noting the positions (shown in dotted lines, Fig. 3) which the sprocket-wheel would occupy in such cases. By my invention these objections are avoided, because the base-plate can be adjusted without changing the position of the bearing-block B.

Figs. 4 and 5 show a modified form of the base-plate, which, in this case, is made in two short angular pieces, P', resting upon plates *o*, provided with raised curved ribs *n*, centering at *d*, Fig. 5. The outer edges of the base-plates P' are made concave, to fit and turn freely upon such ribs when adjusted. The plates P' are also slotted at *c* for the passage of the screw-bolts *a* into the plates *o*, by which means they can be adjusted to change the position of the cam-track. In this modification the bearing-block B rests directly upon its support between the plates P', being bolted in place, as shown.

Having thus described my invention, what I claim as new is—

1. The cam-track of a grain-harvester mounted upon standards *s s*, which are made laterally adjustable upon the machine by means

of the bearing-block B and slotted angular base-plate P, pivoted on the central stud *p* of such block, or their described equivalents, as and for the purpose specified.

2. The block B, constructed with a vertical bearing for the rake-shaft, a lateral bearing for the driving-shaft D, and a central stud, *p*, stepped into the base-plate P, in combination with the cam-track and its supports, substantially as described, for the purpose specified.

3. The slotted base-plate P, constructed

with upturned ends, to which the side standards *s s* of the cam-track are secured, and mounted upon a base-support, so as to be laterally adjustable thereon, under the bearings of the rake-shaft, substantially as described, for the purpose specified.

ORVILLE COOLEY.

Witnesses:

C. D. DEUEY,

E. B. WHITMOR.