

J. J. LACEY.
 Device for Opening and Closing Hatchway-Doors.
 No. 205,192. Patented June 25, 1878.

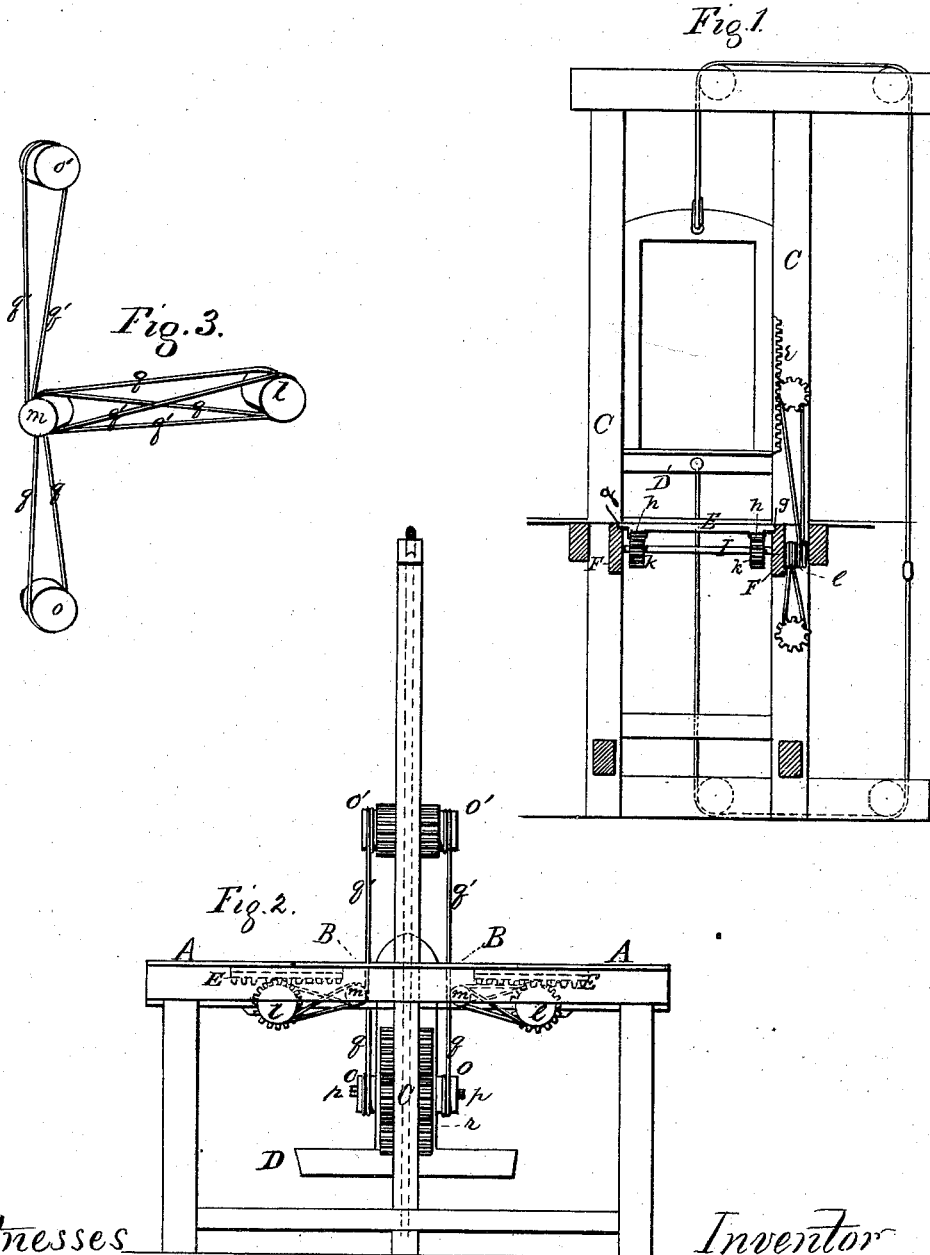

Witnesses
 W. P. Clark
 M. B. Silbert.

Inventor
 John J. Lacey
 by Jno. L. Boone
 his Attorney.

UNITED STATES PATENT OFFICE.

JOHN J. LACEY, OF SAN FRANCISCO, CALIFORNIA.

IMPROVEMENT IN DEVICES FOR OPENING AND CLOSING HATCHWAY-DOORS.

Specification forming part of Letters Patent No. **205,192**, dated June 25, 1878; application filed March 28, 1878.

To all whom it may concern:

Be it known that I, JOHN J. LACEY, of the city and county of San Francisco, in the State of California, have invented an Improved Device for Opening and Closing Hatchway-Doors; and I do hereby declare that the following is a full, clear, and exact description thereof, reference being had to certain drawings accompanying this specification, and forming a part of the same.

My invention has reference to a novel arrangement for automatically opening and closing hatchway-doors by the movement of the elevator platform or cage.

I arrange the doors to slide to and from each other underneath the floor, and meet at a point midway across the hatchway-opening when they are closed. The apparatus for opening the doors on the approach of the elevator cage or platform and closing them after it has passed through their opening is so arranged that the doors are opened by the approach of the cage from either direction, and stand open until it has passed through between them, after which they are closed automatically, all as hereinafter more fully described.

Referring to the accompanying drawings, Figure 1 is a transverse sectional elevation. Fig. 2 is an elevation. Fig. 3 is a plan, showing the arrangements of the pulleys and ropes.

Let A represent one of the floors of a building, through which a hatchway-opening, B, is made to allow an elevator cage or platform to pass through. C C are the upright guide-timbers between which the cage or platform moves, and D is the platform or cage. The hatchway-opening B, I close by means of two horizontally-sliding doors, E E, which meet midway across the opening B when closed, and which move back underneath the floor when opened. To support these sliding doors I secure two timbers, F F, to the under side of the floor, parallel with each other, one on each side of the hatchway-opening, and these timbers extend to a distance on each side of the opening, as represented. Each of these timbers is provided with a ledge or groove, *g*, close to the under side of the floor, in which the opposite edges of the doors E E rest and move, so that the two timbers, with their

grooves, form a supporting-track for the edges of the sliding doors to move and be guided in.

The mechanism for operating the sliding door on one side of the opening is constructed and operated in precisely the same manner as that which operates the door on the opposite side; and as each door and its operating mechanism is independent of the door and mechanism on the opposite side, I will only describe the arrangement for opening and closing one of the doors.

To the under side of the door, near each outer edge, I secure a rack, *h*, parallel with the timbers F F. A shaft, I, extends across from one timber, F, to the other, below the outer end of the door when it is closed, the ends of said shaft being supported in boxes on the under side of the timbers. On this shaft I secure two pinions, *k k*, one in position to engage with each rack *h*. On one end of this shaft I, outside of the timber F, is a pulley, *l*. *m* is a four-grooved pulley, the journals of which are supported in suitable bearings close to the upright guide-timber C on that side.

o is a combined pulley and pinion, which is secured on a spindle, *p*, which projects from the side of the guide-timber F a short distance below the floor; and *o'* is a similar combined pulley and pinion, similarly mounted at the same distance above the floor. A belt, *q*, passes around the pulley *l*, thence passes in one direction over pulley *m*, and thence down around pulley *o*. Another belt, *q'*, passes around pulley *l*, thence in one direction under pulley *m*, and thence up around pulley *o'*.

The pulleys *o* and *o'* are constructed with the pulley part on their outer ends and the pinion on their inner ends. A toothed rack, *r*, is secured to the cage or platform-frame in position to engage with the toothed part of the pulleys *o o'* when the cage moves past them, and the pulleys *o o'* are placed far enough above and below the doors E E to allow this rack to engage and disengage itself at the proper time to prevent any contact between the door and cage.

As before stated, the devices which operate the sliding doors on one side are the same as those which operate the doors on the opposite side, so that the two doors are opened and

closed simultaneously. The racks which operate these two doors can both be placed on one side of the elevator-frame, or they can be placed on opposite sides. In the latter case the pulleys and belts must be arranged to correspond.

Now, as the platform moves upward between the guides C C, the racks *r* engage with the pinion part of the pulleys *o* just before the top of its frame strikes the under side of the doors. The doors are then opened from the middle as the platform-frame rises between them until they are fully opened, when the rack *r* passes pulley *o*, leaving the doors open until the platform passes through, after which the racks *r* engage with the pulley-pinions *o'* above the doors, and the doors are gradually closed.

The rotation of the lower pulley *o* as the platform ascends causes the shaft I to rotate, and its pinions *k k* therefore move the rack *h h* and doors in an opposite direction so as to open the doors. The upper pulleys *o'* are rotated in an opposite direction when the platform moves past them in its ascent, thus rotating shaft I in an opposite direction and closing the doors behind it. As the platform descends the operation of the pulleys *o o'* are reversed, and the doors open and close in the same manner as above described.

A single pinion, *k*, could be secured on the shaft I so as to engage with a single rack on the sliding door; but I prefer to use two pulleys and two racks, as the movement of the

slides or door is more uniform and free. I shall also apply a dog on the side of the cage, one above and the other below the rack, so that if the teeth of pulley and rack are out of position the dogs will set the pulley to correspond.

Various methods of arranging the ropes, pulleys, pinions, and racks could be applied, in order to open and close the sliding doors automatically by the movement of the platform; but their arrangement would be equivalent to that above described.

This arrangement for opening and closing hatchway-doors is simple and convenient. It is out of the way, is not cumbersome or unsightly, and is positive in its action.

Having thus described my invention, what I claim, and desire to secure by Letters Patent, is—

The sliding hatchway-doors E E, supported in the grooves *g g*, and provided with one or more racks, *h*, the shaft I, with its pinions *k k* and pulley *l*, the intermediate pulley *m*, and the combined pulleys and pinions *o o'*, connected by belts *q q*, in combination with the racks *r* on the carriage or platform, the whole combined and arranged to operate substantially as and for the purpose described.

In witness whereof I have hereunto set my hand and seal.

JOHN J. LACEY. [L. S.]

Witnesses:

W. F. CLARK,
J. V. DE VRY.