

W. R. MILLER.
Manufacture of Boots.

No. 205,200.

Patented June 25, 1878.

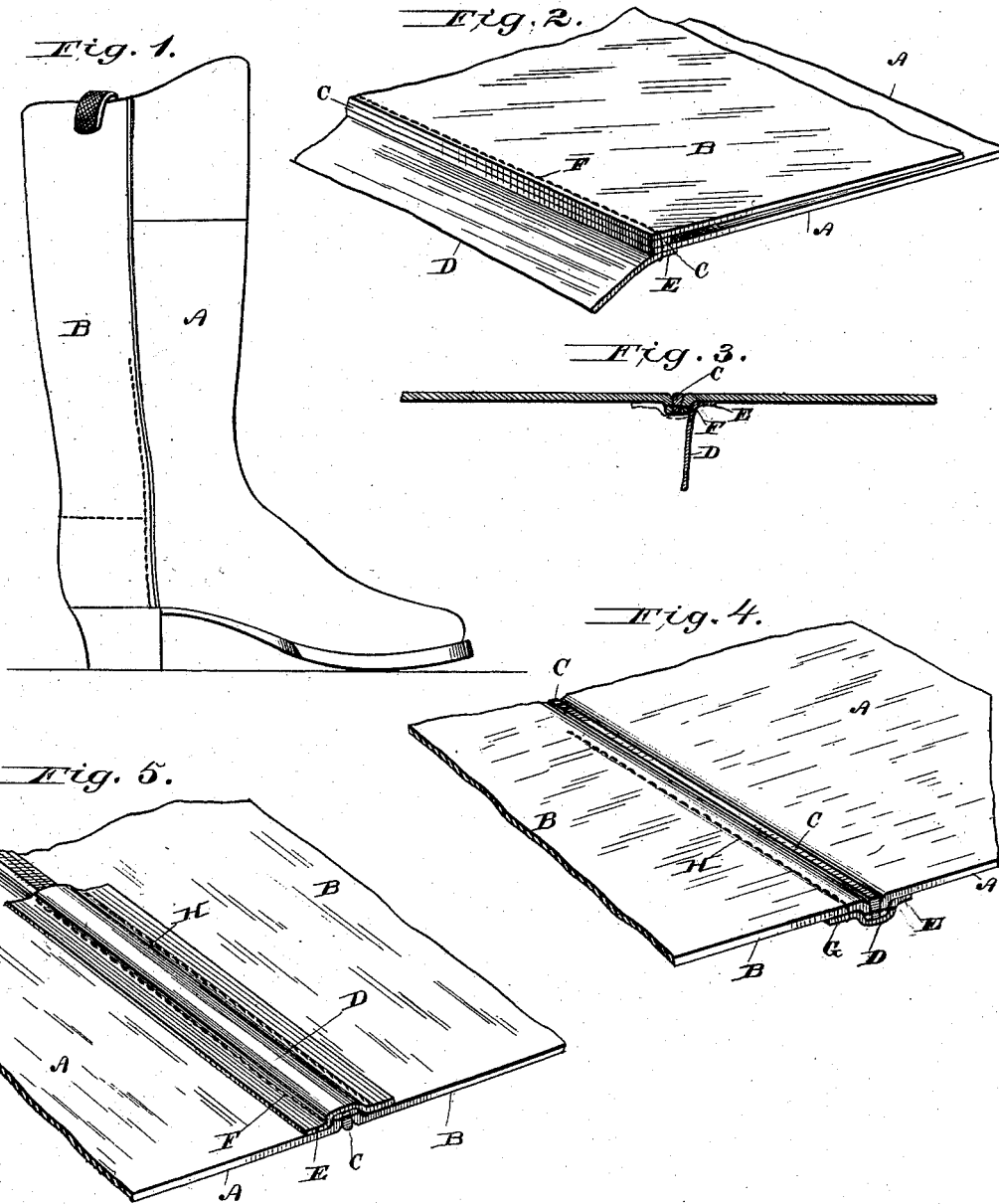

Attest:
H. E. Perrine,
Albin M. Long.

William R. Miller
Inventor.
By H. J. Abbot
Atty.

UNITED STATES PATENT OFFICE.

WILLIAM R. MILLER, OF BALTIMORE, MARYLAND.

IMPROVEMENT IN MANUFACTURE OF BOOTS.

Specification forming part of Letters Patent No. **205,200**, dated June 25, 1878; application filed June 3, 1878.

To all whom it may concern:

Be it known that I, WM. R. MILLER, of Baltimore, in the county of Baltimore and State of Maryland, have invented certain new and useful Improvements in the Manufacture of Boots; and I do hereby declare that the following is a full, clear, and exact description thereof.

This invention relates to certain improvements in the manufacture of boots; and the invention consists in a side seam formed and protected as will be hereinafter more fully set forth.

In order to enable others skilled in the art to which my invention appertains to make and use the same, I will now proceed to describe its construction and arrangement, reference being had to the accompanying drawing, which forms a part of this specification, and in which—

Figure 1 is a side elevation of a boot having the back and front secured together by the seam hereinafter described. Fig. 2 is a view showing one side of the protector secured in forming the side seam. Fig. 3 is a sectional view, showing the back and front stretcher or extender after being secured together, with the stay-strip partially secured. Fig. 4 is a view showing the other side of the protector or stay-strip, secured by a row of stitches, and Fig. 5 is an inside view of the side seam and protector or stay-strip, all united in accordance with my invention.

In the drawings, A denotes the front, and B the back. In forming the side seam the parts

A and B are placed back to back, and a welt, C, interposed between the two edges. A strip of leather, D, is then arranged with one edge, E, under the aforesaid parts, and is then secured by a row of stitches, F, passing through the parts A and B and the welt C, as shown in Fig. 2 of drawing. The front and back are then extended, as shown in Fig. 3 of drawing, and the edge G of the stay-strip D is secured by a row of stitches, H, on one side of the eye-seam, passing through the back B, as shown in Figs. 4 and 5 of drawing.

A side seam having the rib on the inside of the leg, covered by a strip of leather secured by two rows of stitches, one on each side of the eye-seam, is old, and I would not, therefore, be understood as claiming any such construction as my invention.

Having thus fully described my invention, what I claim as new, and desire to secure by Letters Patent, is—

The seam of a boot protected by a stay-strip, one side of which is secured in the seam which unites the parts of the upper together, the other side being folded over the seam and stitched to one of said parts, substantially as shown and described.

In testimony that I claim the foregoing as my own I affix my signature in presence of two witnesses.

WM. R. MILLER.

Witnesses:

H. B. BROWN,
ALBIN M. LONG.