

J. WEATHERBEE & I. MOWDER.
Vegetable-Cutter.

No. 205,223.

Patented June 25, 1878.

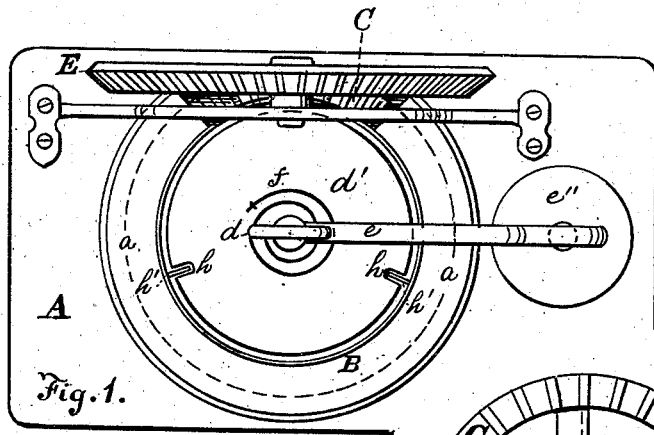

Fig. 4.

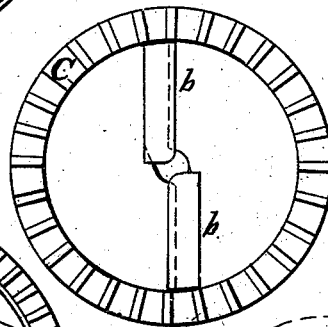
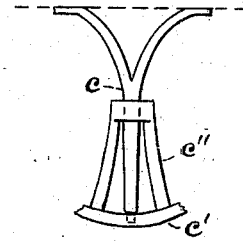
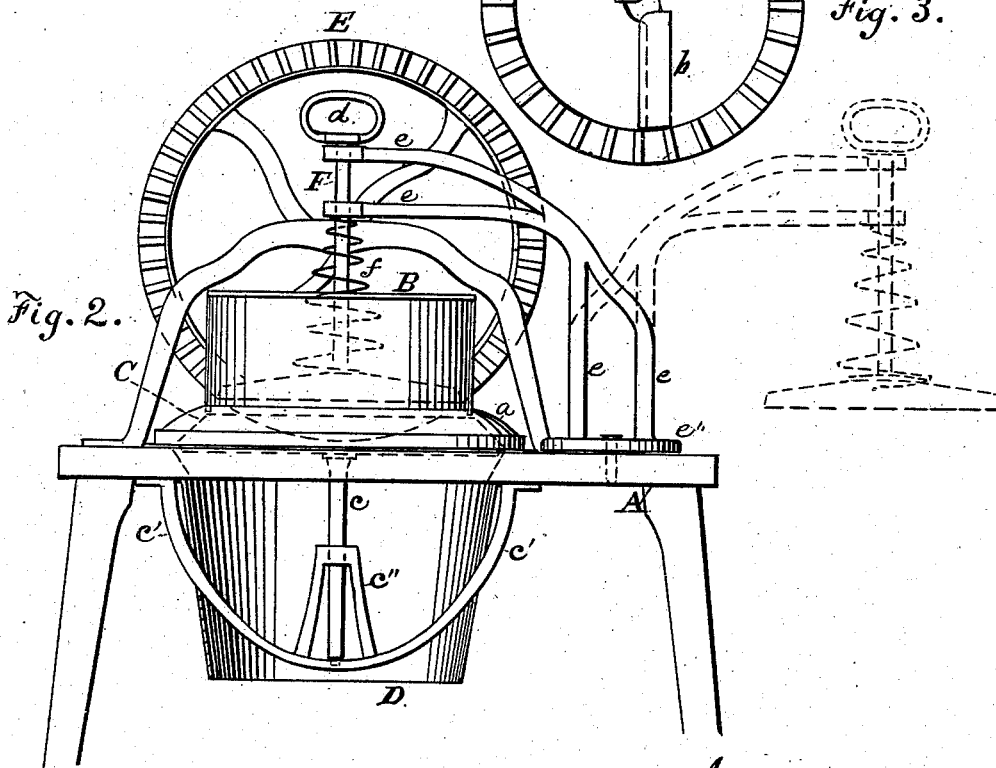

Fig. 3.



Witnesses:
W. Burris
P. B. Turpin

Inventor:
James Weatherbee & Isaac Mowder,
by Gilbert B. Towles.
Attorney.

UNITED STATES PATENT OFFICE.

JAMES WEATHERBEE AND ISAAC MOWDER, OF PORT WASHINGTON, OHIO.

IMPROVEMENT IN VEGETABLE-CUTTERS.

Specification forming part of Letters Patent No. 205,223, dated June 25, 1878; application filed March 30, 1878.

To all whom it may concern:

Be it known that we, JAMES WEATHERBEE and ISAAC MOWDER, of Port Washington, in the county of Tuscarawas and State of Ohio, have invented certain new and useful Improvements in Vegetable-Cutters; and we do hereby declare that the following is a full, clear, and exact description thereof, which will enable others skilled in the art to which it appertains to make and use the same, reference being had to the accompanying drawings, and to letters of reference marked thereon, which form a part of this specification.

Figure 1 is a plan view of our improved vegetable-cutter; Fig. 2, a side elevation, showing the hopper below in section; Fig. 3, a plan view of revolving cutters, and Fig. 4 a view of shaft of cutter-wheel detached.

Like letters in all the figures of the drawings indicate like parts.

This invention relates to the class of vegetable-cutters having a table or stand provided with a hopper, in which are arranged revolving cutters or knives operated by suitably-arranged beveled gearing; and it consists of a sliding standard, with an automatic follower, arranged to automatically feed the vegetables in the hopper to the cutters, as will be hereinafter more fully explained.

A is the table; B, a cylindrical receiving-hopper, having a flanged covering, *a*, over the cogs of the horizontally-arranged beveled gear-wheel C, and fastened to the table by means of the covering *a*. The inner sides of the hopper are flush with the inner periphery of the beveled gear-wheel. The space on the inside of the wheel is made solid, excepting the openings for the cutters *b b*, which are so fastened therein that they can be adjusted and taken out and sharpened when necessary.

The gear-wheel C, thus constructed with the cutters, is supported underneath centrally by a vertical shaft, *c*, the bottom end of which is stepped on the curved cross-bar *c'*, provided with a bearing-brace, *c''*, attached at each end to the under side of the table. The upper end of the shaft *c* branches out into two arms, (see Fig. 4,) which are attached to the under side of the wheel, and form a brace or bearing for the same. The under side of the table is provided a discharge-hopper, D, of a cylindrical

inclined form, the curved cross-bar *c'* passing through and across it.

A vertically-arranged beveled gear-wheel, E, provided with a crank-handle, and having its shaftal bearing in a brace attached to the top of the table, and gearing with wheel C, is made to operate the revolving cutters. F, the sliding standard, provided at its upper end with a handle, *d*, and at its bottom end with the automatic follower *d'*, and having its bearing in the double swinging brace-arms *e e'*, which are constructed and attached to a circular plate, *e''*, having a pivotal connection on the table, so as to permit the follower to be lifted out of the hopper and swung to one side, to allow the vegetables to be placed therein.

A spiral spring, *f*, is interposed between the inner arms of the brace *e e'* and the follower, to cause the latter, when the hopper is filled with vegetables to be cut, to press automatically down upon the vegetables, and thus feed them to the cutters.

The edge of the follower is provided with three or more slots, *h*, at equal distances apart, which are made to fit over an equal number of guides, *h'*, attached to the sides of the hopper B, so as to keep the follower from binding against the sides thereof.

The operation is as follows: The follower is lifted up out of the hopper by the handle *d* and swung to one side, (see the same in dotted lines in Fig. 2,) when the vegetables to be cut are placed in the hopper and the follower swung back again, the automatic pressure of the follower upon the vegetables feeding them to the cutters, thus saving the inconvenience and necessity of pressing the follower down upon the vegetables by hand.

Having thus fully described our invention, what we claim therein as new, and desire to secure by Letters Patent, is—

1. A vegetable-cutter having a pivotal swinging arm provided with a sliding standard, having a follower arranged to automatically feed the vegetables to the cutters, substantially as and for the purpose set forth.

2. The double swinging brace-arms *e e'*, constructed and attached to a plate pivoted to the table, and having the sliding standard F, provided with the handle *d*, follower *d'*, and spiral spring *f*, in combination with the re-

volving cutters *b b* and receiving-hopper B, substantially as described.

3. The combination of the pivotal swinging arms *e e*, sliding standard F, automatic follower *d'*, spring *f*, beveled gear-wheel C, revolving cutters *b b*, shaft *e*, cross-bar *c'*, brace *c''*, hopper B, covering *a*, beveled gear-wheel E, and hopper D, substantially as and for the purpose set forth.

In testimony that we claim the foregoing as our own invention we affix our signatures in presence of two witnesses.

JAMES WEATHERBEE.
ISAAC MOWDER.

Witnesses:

JOHN CROFT,
F. G. HELMS.