

E. T. MARBLE.
Cloth-Finishing Machine.
No. 205,281. Patented June 25, 1878.

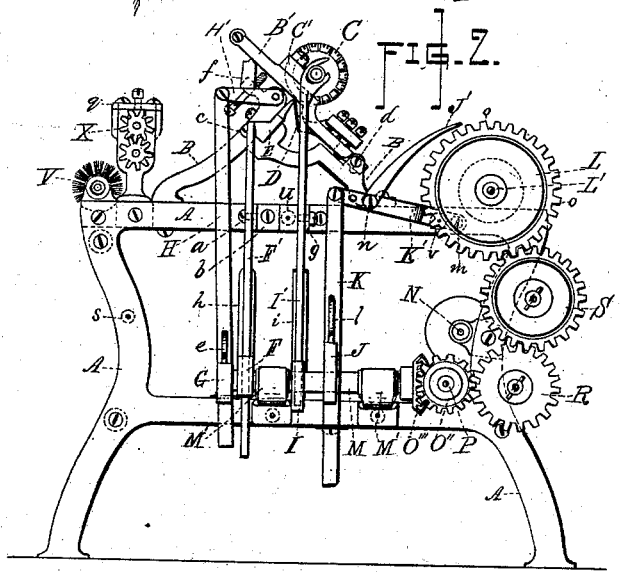
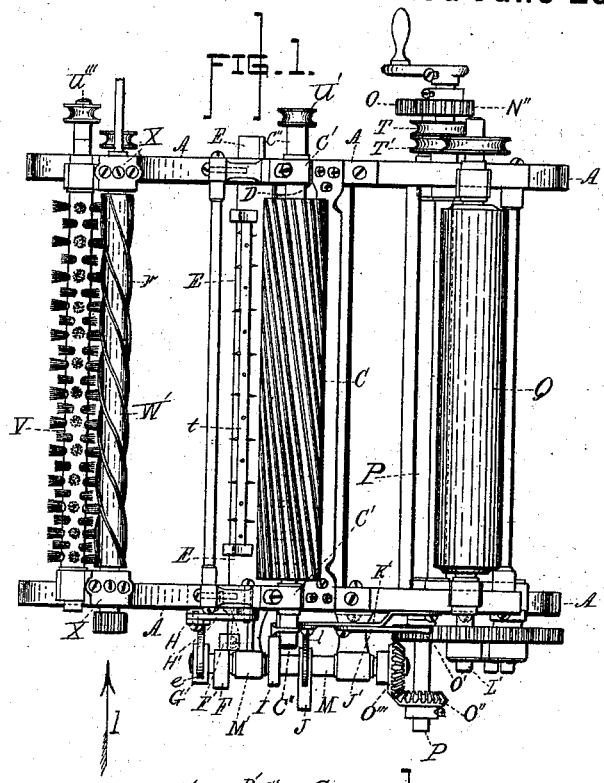

Witnesses;

George Dodge
Edwin C. Hoard

Inventor;

Edwin T. Marble

E. T. MARBLE.
Cloth-Finishing Machine.
No. 205,281. Patented June 25, 1878.

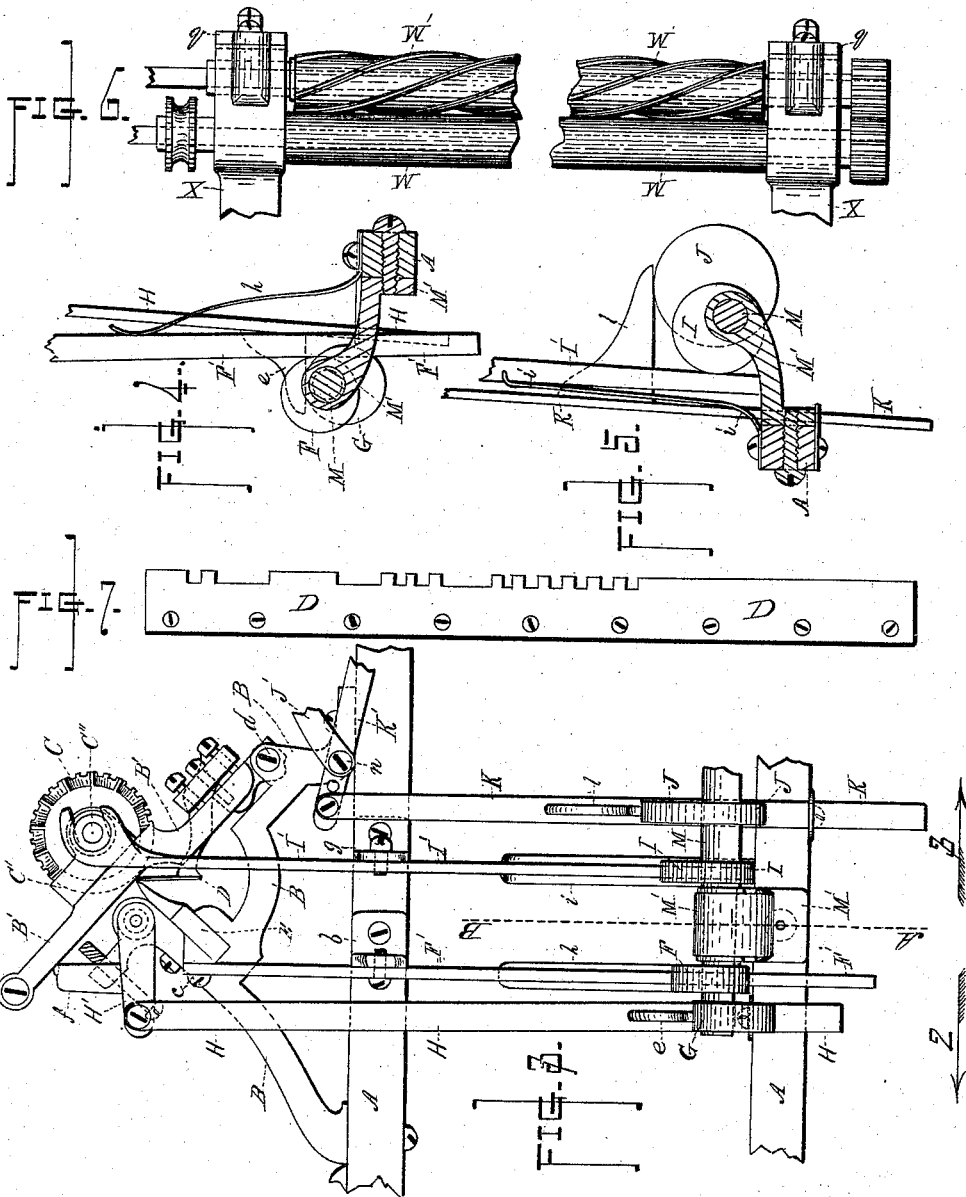

Witnesses;
Thos. G. Dodge
Edwin E. Hoard

Inventor;
Edwin T. Marble

UNITED STATES PATENT OFFICE.

EDWIN T. MARBLE, OF WORCESTER, MASSACHUSETTS.

IMPROVEMENT IN CLOTH-FINISHING MACHINES.

Specification forming part of Letters Patent No. 205,281, dated June 25, 1878; application filed January 17, 1878.

To all whom it may concern:

Be it known that I, EDWIN T. MARBLE, of the city and county of Worcester, and Commonwealth of Massachusetts, have invented certain new and useful Improvements in Shearing-Machines for Cutting Different Figures or Designs on Cloth; and I do hereby declare that the following is a full, clear, and exact description of the same, reference being had to the accompanying drawings, forming a part of this specification, and in which—

Figure 1 represents a top or plan view of my said improved machine. Fig. 2 represents a side view of the same, looking in the direction indicated by arrow 1, Fig. 1. Fig. 3 represents, upon an enlarged scale, a side view of so much of the machine as is necessary to illustrate my present invention, which will be hereinafter more fully described. Fig. 4 represents, upon an enlarged scale, a vertical section taken on line A B, Fig. 3, looking in the direction indicated by arrow 2 of the same figure. Fig. 5 represents, upon an enlarged scale, a vertical section taken on line A B, Fig. 3, looking in the direction indicated by arrow 3 of the same figure. Fig. 6 represents, upon an enlarged scale, a side or end view of a portion of the machine, as will be hereinafter more fully described; and Fig. 7 represents, upon an enlarged scale, a side view of the ledger-blade of my improved machine, showing some of the different ways in which the edge may be notched or cut out to produce, in connection with the other parts of the machine, the desired figure or design upon the cloth.

To enable those skilled in the art to which my invention belongs to make and use the same, I will proceed to describe it more in detail.

In the drawings, the parts marked A represent the main frame-work of the machine, and B the frame-work upon which the revolving cylinder C and ledger-blade D are arranged, said frame B being secured to the main frame A. E represents a sliding rest, over which the cloth passes, and is operated to slide back and forth laterally by means of a cam, F, through cam-lever F', which is fulcrumed at *a* upon a projecting stand, *b*, secured to main frame A, the upper end of said lever being hinged at *c* to the end of sliding rest E.

The part B' of frame B is arranged to swing up and down upon a pivot at the point *d* upon frame B, and is operated by means of a cam, G, through a jointed cam-lever, H H', the lower end of the part H being provided with a foot, *e*, adapted to rest upon the cam, while the upper section H' is provided with a projecting arm, *f*, which bears against and communicates the motion to the swinging portion B' of frame B. Thus the action of cam G, in rotating, is imparted to swinging frame B' in raising the cylinder C and ledger-blade D above the cloth, and vice versa. Revolving cylinder C is also arranged to slide back and forth laterally in bearings C' C', and is operated by cam I through a cam-lever, I', pivoted upon a projecting stand, *g*, secured to main frame A. The upper end of lever I' is made in this instance in the form of a fork, which fits into a groove cut upon shaft C'' of revolving cylinder C, so that as cam I rotates its action is imparted to revolving cylinder C in sliding it back and forth, the purpose of which, as well as the operation of the cam F, will be hereinafter more fully described.

Cam-levers F' and I' are both kept against the respective cams operating them by means of springs *h* and *i*, secured to the main frame A.

Cam J is for the purpose of operating pawl J' to feed forward the cloth, so as to produce certain designs or figures upon it, as will be hereinafter more fully described.

The motion of cam J is imparted to pawl J' by means of a jointed lever composed of the parts K and K'. The part K is provided with a foot, *l*, which rests upon and receives the action of cam J, while the upper part K' is hinged upon frame A at the point *m*, (shown in dotted lines, Fig. 2,) and upon it, at the point *n*, is fulcrumed the end of pawl J'. When said pawl J' is not to be employed in turning the draft-roll, it may be elevated above teeth *o* on spur-gear L, as represented in Fig. 2, and there held by turning the tightening-screw at the point at which it is fulcrumed.

Cams F, G, I, and J are all arranged and secured upon shaft M, which turns in bearings M' M', secured to main frame A, and driving-power is or may be imparted to them from the main driving-pulley, secured upon the end of shaft N, through spur-gear N'', secured upon

shaft N, spur-gear O O', and beveled gear O'', secured upon connecting-shaft P, and beveled gear O''', secured upon the end of the before-mentioned shaft M.

Driving-power is also imparted to draft or carrying roll Q from connecting-shaft P through spur-gear O', gears R and S, turning on bearings secured to frame A, and gear L, keyed upon the end of shaft L', upon which the draft-roll is secured.

Upon shaft N, between spur-gear N'' and main frame A, are secured two pulleys, T and T', for the purpose of driving, by means of suitable belts, pulleys U' and U''' and their respective shafts and the parts connected therewith, as may become necessary to operate such parts, to produce the desired figure or design upon the cloth.

V is a brush-roll, for the purpose of raising the nap upon the cloth as it enters the machine.

W and W' are pattern or design rolls, turning in bearings X X, secured to main frame A, through which steam is passed. The lower roll W may be smooth, or depressed figures may be formed upon it, while upon the upper roll W' are formed raised ribs or figures, said figures being in accordance with the designs desired to be imprinted upon the cloth to be operated upon.

The pressure of the upper roll upon the cloth is governed by means of adjusting or compressing screws in caps q q.

In the drawings, a serpentine rib, r, is formed upon design-roll W', which produces a diagonal stripe across the cloth, all as is well known.

In producing designs upon the cloth by the last above-described operation, none of the automatic motions produced by the cams hereinbefore described are used. The edges of blade C and surface of revolving blade D are smooth instead of notched, as represented in the drawings.

To cut different designs or figures upon the cloth without the employment of steam-rollers W and W', the operation is as follows:

To cut simply longitudinal stripes through the cloth, none of the automatic motions produced by cams F, G, I, and J are used; but the blades, instead of being smooth, are notched out, as represented in Fig. 7 of the drawings, said notches being of the width of the stripes desired to be produced upon the cloth.

To cut longitudinal zigzag stripes through the cloth, the automatic motion of giving to sliding rest E a lateral motion is required, the form and width of the stripes being governed by the manner in which the notches are cut in blades C and D and the form and size of cam F.

To cut both longitudinal and zigzag stripes

through the cloth at the same time, either the sliding rest E or revolving cylinder C is required to be given a lateral motion by the cams F and I, respectively, the form and width of the stripes being also governed, as in making a single zigzag stripe, by the manner in which the notches are cut in cylinder C and ledger-blade D, and the form and size of the cams operating said parts.

To cut a stripe crosswise of the cloth, levers F' and I' are disconnected from the machine, the automatic motions produced by cams G and J only being in operation.

As the cloth passes forward, cam G raises or lowers swinging frame B', as the case may be, upon which the cylinders C and D are arranged, which operation is performed alternately with the action of cam J, through lever K K' and pawl J', in carrying forward the cloth upon draft-roll Q.

When the last mentioned operation is being performed upon the cloth gear S is disconnected.

In this instance of cutting a stripe crosswise of the cloth, as in the first mentioned, where steam-rolls W and W' are used, revolving cylinder C and ledger-blades D may be formed with smooth edges or notched, as represented in the drawings, the distance between the stripes also being governed by the form and size of cams F and J operating their respective parts.

Many other figures or designs than those described in the foregoing description may be made upon the cloth by simply changing, as before explained, the form and size of the cams operating the several parts, and in the manner of notching the edges of the cylinder C and ledger-blade D, and also by changing the figures cut upon the rolls W W'.

Having described my improvements in cloth shearing and figuring machines, what I claim therein as new and of my invention, and desire to secure by Letters Patent, is—

1. The combination and arrangement of cam F and lever F' with sliding rest E, substantially as and for the purpose described.

2. The combination and arrangement of cam J, jointed lever K K', and pawl J' with draft-roll Q and shearing mechanism, substantially as and for the purpose described.

3. The combination and arrangement of cam-shaft M, cams F, G, I, and J, and levers F', H H', I', and K K' with rest E, frame B, revolving blade C, draft-roll Q, and figuring-rolls W W', substantially as and for the purpose specified.

EDWIN T. MARBLE.

Witnesses:

THOS. H. DODGE,
EDWIN E. MOORE.