

M. J. McEWAN.
Water-Closet.

No. 205,284.

Patented June 25, 1878.

Fig: 1

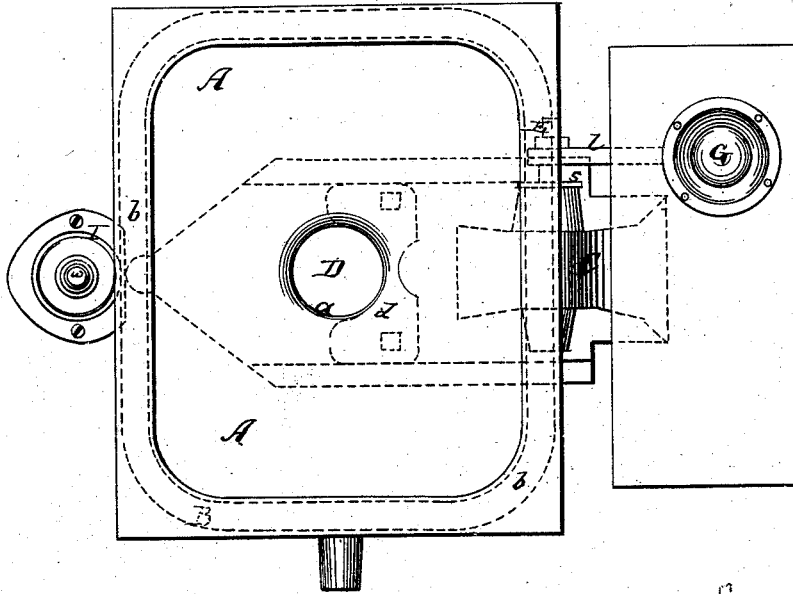

Fig: 2

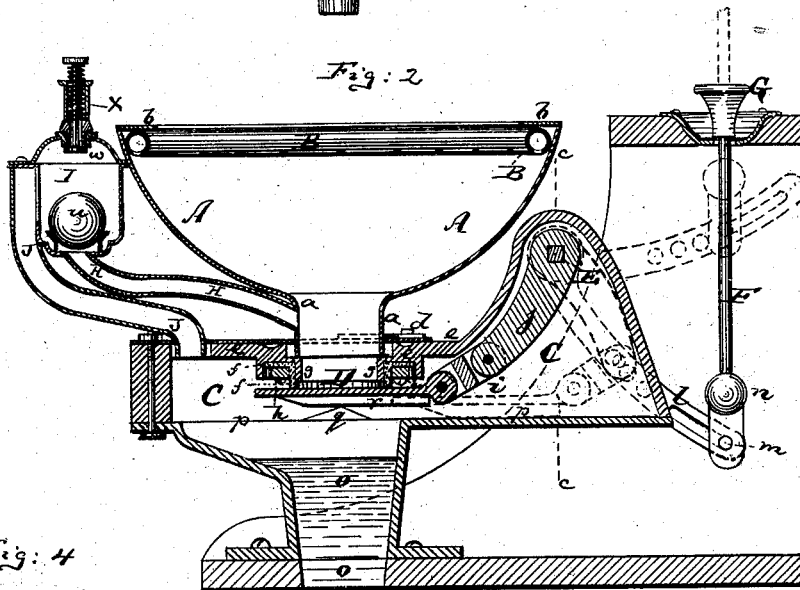

Fig: 4

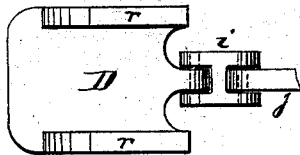
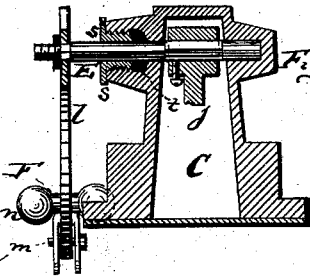

Fig: 3



Witnesses:

A. Briesen
John C. Sunbridge

Inventor:

M. J. McEwan
By his attorney
A. Briesen

UNITED STATES PATENT OFFICE.

MICHAEL J. McEWAN, OF NEW YORK, N. Y.

IMPROVEMENT IN WATER-CLOSETS.

Specification forming part of Letters Patent No. 205,284, dated June 25, 1878; application filed December 17, 1877.

To all whom it may concern:

Be it known that I, MICHAEL J. McEWAN, of the city, county, and State of New York, have invented a new and useful Improvement in Water-Closets, of which the following is a specification:

Figure 1 is a plan or top view of my improved water-closet. Fig. 2 is a vertical longitudinal central section of the same. Fig. 3 is a detail vertical transverse section thereof on the line *c c*, Fig. 2. Fig. 4 is a detail bottom view of the sliding valve.

Similar letters of reference indicate corresponding parts in all the figures.

This invention relates to several improvements in water-closets of the kind described in Letters Patent No. 187,545, dated February 20, 1877.

The principal object of the present invention is to bring the knob for operating the valve of the closet nearer to the seat than can be done by the construction referred to in the above-mentioned patent, because in said construction a long horizontal spring is specified as placed in line with the valve, the length of the spring being considerable for the purpose of allowing sufficient motion of the valve.

In the present invention I substitute a weighted knob or knob-rod for the spring and a novel system of levers for the mechanism which connects the knob with the sliding valve, and am thereby enabled to bring the knob close to the seat and to insure a perfectly satisfactory movement of all the parts.

Another object of the invention is to cause the valve to fit very tightly against its seat in the pan while closing the same, and yet to provide freedom of motion of the valve; and to this end I employ inclined ribs, on which the valve is raised when it is closed against its seat, but from which it moves away when withdrawn from the bowl or pan.

Further details of the invention will be hereinafter described with reference to the overflow and the packing of the rock-shaft, which connects with the sliding valve by links or levers, and to other parts of the mechanism which enter into combination with said valve and with the overflow in the basin.

In the accompanying drawing, the letter A represents the water-closet bowl or pan, made

of porcelain or other suitable material, and constructed with a contracted lower discharge portion or neck, *a*, which is clearly illustrated in Fig. 1.

The top of the bowl has an inwardly-projecting flange, *b*, which serves as an additional means of supporting the seat, and also as a protector to the water-pipe B, which is placed directly beneath said flange, as clearly shown in Fig. 2. The neck or contracted lower portion *a* of the bowl is inserted into a box, C, which is made of cast-iron or other suitable material, and which has an opening in its top plate *e* of a size and shape to enable it to properly receive the neck *a*, as indicated in Fig. 2.

The neck may be properly steadied in the opening of the box C by a plate, *d*, placed upon the box C, and caused to partly embrace the neck *a*, as indicated by dotted lines in Fig. 1.

Into an annular recess formed on the under side of the top plate *e* of the box C is placed, around the discharge opening from the bowl, a packing-ring, *f*, of india-rubber or other suitable material. This ring is placed against the outer periphery of a circular flange, *g*, which projects downwardly from the plate *e* directly below the neck *a*, as shown in Fig. 2.

An annular ring, *h*, is, from below, placed against a portion of the packing-ring *f*, and secured by screws or otherwise, so as to securely hold said packing-ring in position.

The rubber packing *f* projects downwardly below the flange *g* and below the ring *h*, as shown in Fig. 2, and this projecting portion is sufficiently flexible to cause it to form a flexible seat for the sliding valve D, which is placed against it from beneath in closing the bowl, as shown in Fig. 2. Said sliding valve D connects, by a link, *i*, with a crank, *j*, of a rock-shaft, E, said rock-shaft being hung in an upward enlargement of the box C, as shown in Figs. 2 and 3. Another crank, *l*, projects upwardly—that is to say, at nearly right angles to the crank *j*—from the rock-shaft E, and is slotted at its outer end to receive in the slot a pin, *m*, that joins it to the lower end of the rod F, whose upper end carries the pull-knob or handle G.

The rod F is provided with a proper weight or weights, *n*, which have the tendency to pull

it down vertically and to hold the knob or handle in its lowermost position, and thereby also to push the valve D under the neck of the bowl A; but on pulling the knob G and raising the rod F the crank *l* is swung up into the dotted position shown in Fig. 2, the rock-shaft E vibrates, and the crank *j* swung downward or toward the rod F, so as to withdraw the valve D from below the neck *a* of the bowl, thereby permitting the discharge of the contents of the bowl into the sewer-pipe, which connects with a lower discharge-pipe, *o*, that is formed on the box C, as also clearly shown in Fig. 2.

The position of the open valve D and its connection with the rod F is clearly indicated by dotted lines in Fig. 2.

The bottom plate *p* of the box C is provided with inverted V-shaped or inclined ribs *q*, which serve to elevate the valve D against the rubber packing *f* when the valve closes the bowl, as in Fig. 2. The lower surface of the valve D is or may be provided with similar ribs *r*, having inclined ends, as shown in Fig. 2, which ribs ride on the ribs *q*. Thus in closing the valve it is raised and tightly pressed against the packing-ring, to insure a close airtight fit, and thus prevent the escape of noxious gases from the sewer-pipe into the bowl; but when the valve is drawn open it slides off the ribs *q*, and is therefore free to move, rendering it less difficult to operate the pull or handle than it would be were the valve always lightly held against the packing.

It is quite clear that the ribs *q* are not necessarily V-shaped as long as that edge which they turn to the approaching valve is inclined in the manner shown or rounded; and I desire it to be understood that the ribs *r* on the valve itself are not absolutely necessary, as the ribs *q* may suffice to raise the valve properly against the packing.

In order to prevent the escape of noxious gases at the point at which the rock-shaft E enters the box C, I pass said shaft through a stuffing-box, *s*, which clamps a packing, *t*, against the shaft, as indicated in Fig. 3, and thereby renders the escape of gases around the shaft E impossible.

For facilitating the movements of the parts, the outer end of the crank *l* is slotted, as shown in Fig. 2, the pin *m* passing through the slot, so that thereby the parts will not be strained in moving the rod F up and down; and I further adapt the crank *l* to application to more or less contracted rooms by providing it with a series of apertures above its lower end, so that the rod F may be connected with either one of said apertures or slots should the space to which the closet is to be fitted not suffice to allow the entire length of the crank *l* to be utilized, although of course it is preferable and affords better leverage to use the entire length of said crank.

The overflow-pipe H of the bowl connects to the lower portion thereof, and enters an elevated chamber, I, from which another pipe,

J, leads into the box C and communicates with the discharge-opening *e* of said box. The upper end of the pipe H is closed by a spherical valve, *u*, which is made of wood or other light material capable of floating on water, so that, in case of an overflow, or rather to guard against an overflow when too much water is admitted into the basin, the water may rise in the pipe H, float the valve *u*, and pass off into the sewer through the pipe J. When the water sinks to its proper level in the basin the valve *u* resumes its place on the pipe H and closes the same, and serves thus to prevent noxious gases from entering the bowl through the pipes J, chamber I, and pipe H.

I thus provide a double guard against the escape of noxious gases into the basin—the one being the valve D, tightly fitting against the packing *f*, and the other the spherical valve *u*, closing the overflow-pipe H.

In order to prevent a constant outflow of water through the pipe H, chamber I, and pipe J, by siphon action, in case the flow through these parts is once started, I place in the top of the chamber I a downwardly-opening valve, *w*, which is raised against its seat by a very tender spring, *x*, and which, in case of a continuous flow, will be drawn open by the current of water, and admit air into the chamber I, to counteract the siphon action and prevent further flow of the water.

It is evident that the weight or weights *n*, instead of being placed on the rod F, may be placed on the crank *l*, or on a separate crank on the rock-shaft E; also that, instead of such weights, equivalent springs, acting vertically on the rod F, may be used.

The invention is also applicable to sinks.

I claim—

1. The packing-ring *f*, placed into a recess in the under side of the plate *e* of the box C, and combined with the annular plate *h* and flange *g* so that it projects below said flange *g* and plate *h* and around the discharge-end of the bowl A, substantially as herein shown and described.

2. The combination of the bowl A with the box C and downwardly-projecting packing-ring *f*, and with the sliding valve D, substantially as herein shown and described.

3. The combination of the sliding valve D with the inclined raising-ribs *q* and upper packing-ring *f*, substantially as and for the purposes specified.

4. The combination of the inclined raising-rib *q* in the box C with the rib or ribs *r* on the valve D, substantially as and for the purposes herein shown and described.

5. The combination of the sliding valve D with the crank *j*, rock-shaft E, crank *l*, and weighted rod F, substantially as herein shown and described.

6. The combination of the box C, containing the sliding valve D and crank *j*, with the rock-shaft E and stuffing-box *s*, substantially as and for the purposes specified.

7. The combination of the water-closet basin A with the overflow-pipe H, chamber I, discharge-pipe J, and floating valve *u*, substantially as herein shown and described.

8. The combination of the pipes H J and chamber I with the downwardly-opening valve *w*, placed into the chamber I, substantially as and for the purpose specified.

9. The combination of the water-closet bowl A and box C with the sliding valve D and

projecting packing *f*, and with the discharge-pipes H J, chamber I, and spherical valve *u*, all arranged to constitute a double inclosure to the lower part of the bowl, substantially as specified.

MICHAEL J. McEWAN.

Witnesses:

T. B. MOSHER,
F. V. BRIESEN.