

M. H. ROGERS.  
Newspaper Folding-Machine.

No. 205,301.

Patented June 25, 1878.

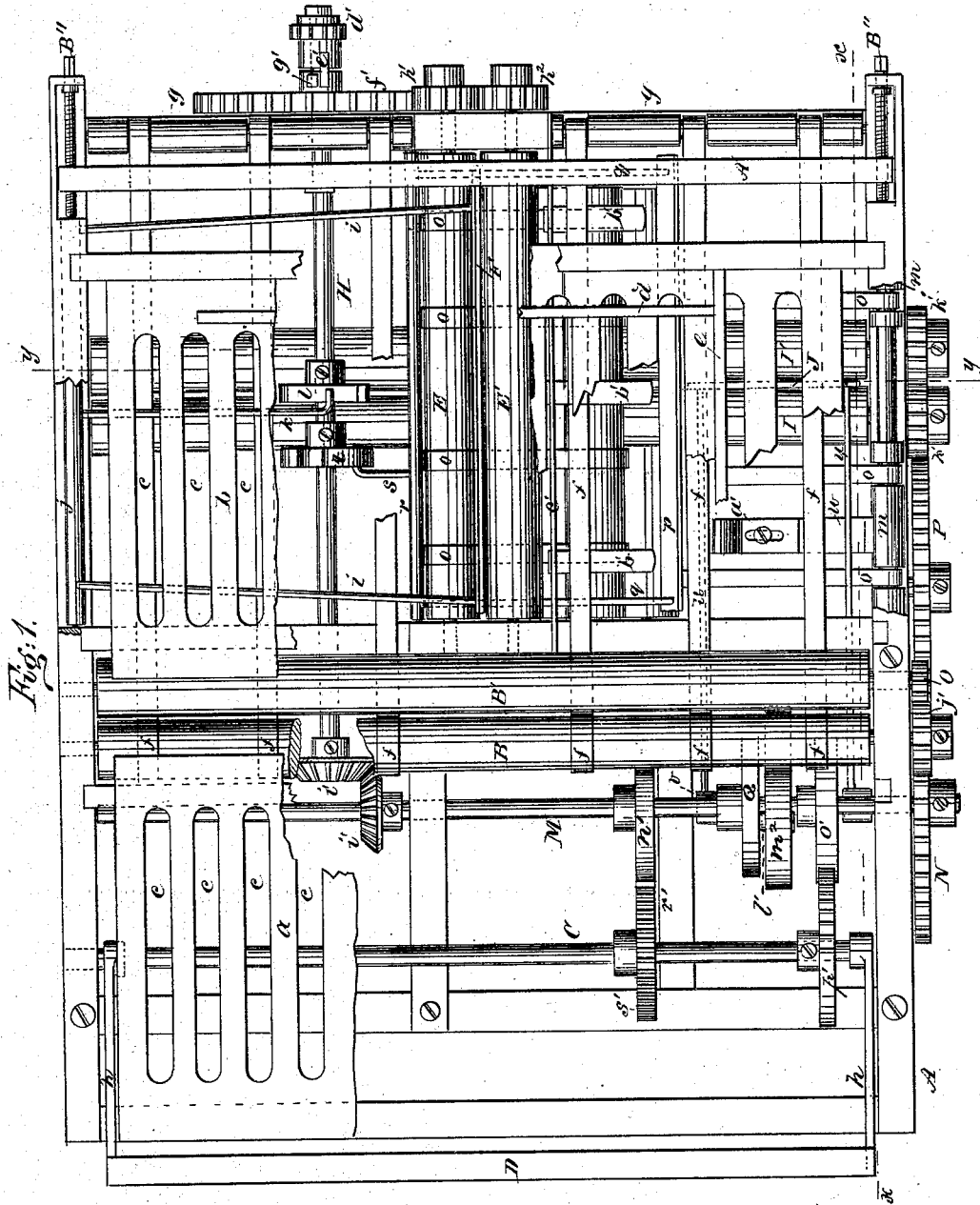

Fig. 1.

WITNESSES:

*Chas. Nida*  
*C. Sedgwick*

INVENTOR:

*M. H. Rogers*  
BY *Munn & Co*

ATTORNEYS.

M. H. ROGERS.  
Newspaper Folding-Machine.

No. 205,301.

Patented June 25, 1878.

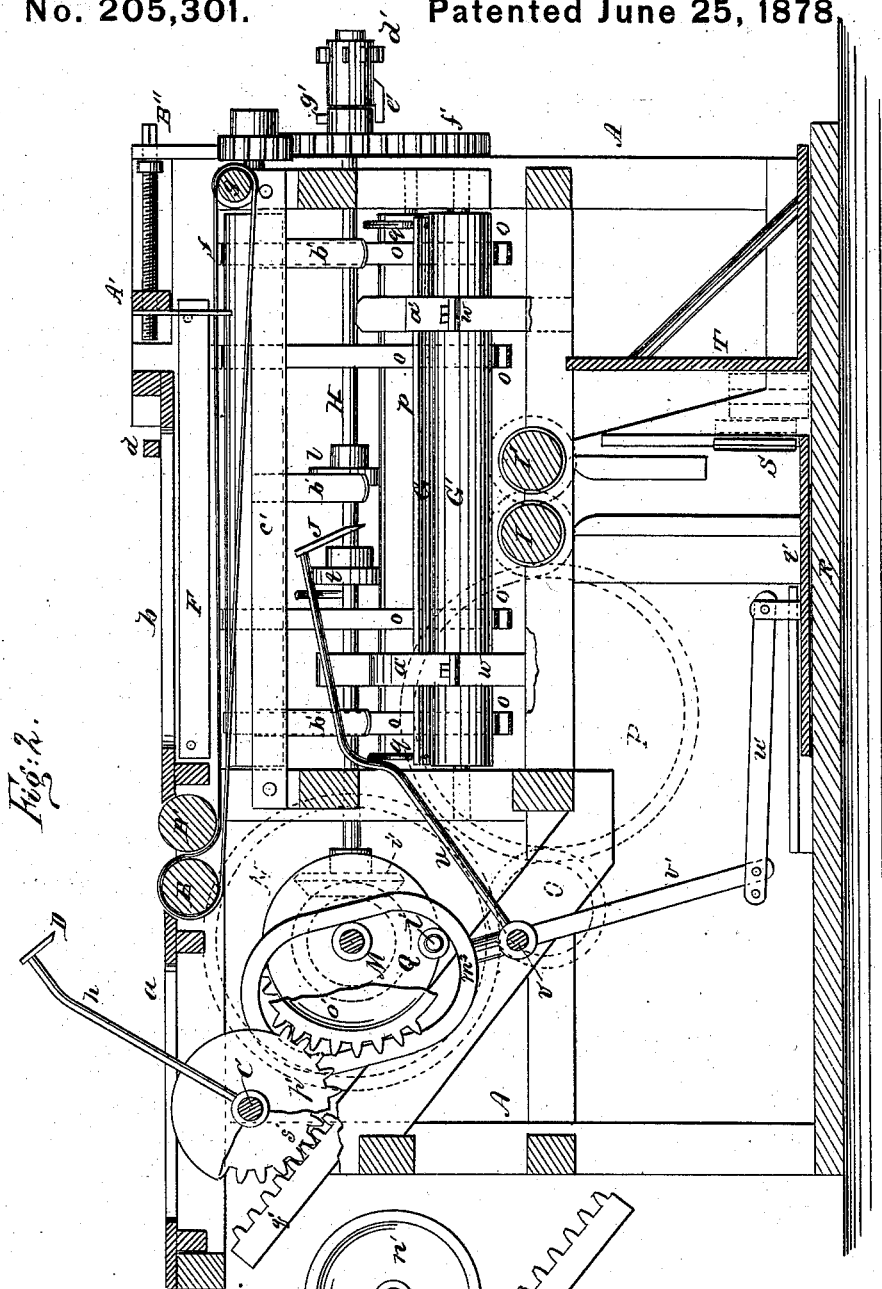
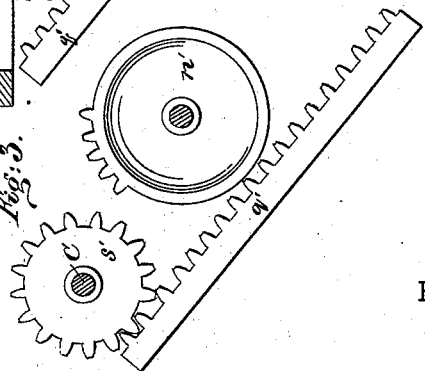

Fig. 2.

WITNESSES:

*Chas. N. ...*  
*C. Sedgwick*

Fig. 3.



INVENTOR:

*M. H. Rogers*  
BY *Munster*

ATTORNEYS.

M. H. ROGERS.  
Newspaper Folding-Machine.

No. 205,301.

Patented June 25, 1878.

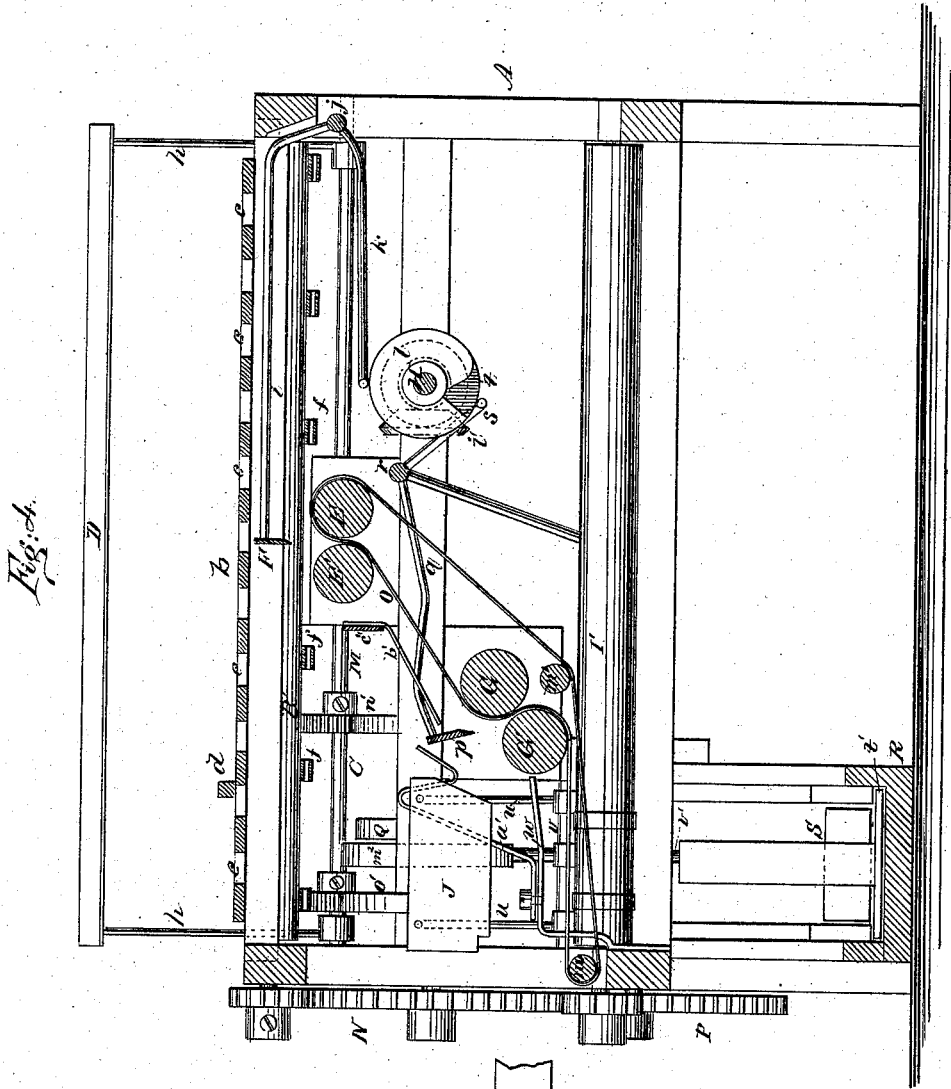

Fig: 4.

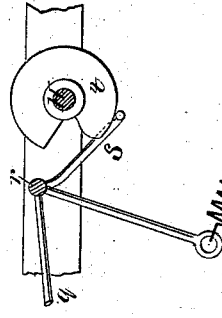

Fig: 5.

WITNESSES:  
*Cnas. Nida*  
*C. Sedgwick*

INVENTOR:  
*M. H. Rogers*  
 BY *[Signature]*  
 ATTORNEYS.

# UNITED STATES PATENT OFFICE.

MARCUS H. ROGERS, OF GREAT BARRINGTON, MASSACHUSETTS.

## IMPROVEMENT IN NEWSPAPER-FOLDING MACHINES.

Specification forming part of Letters Patent No. **205,301**, dated June 25, 1878; application filed January 14, 1878.

### *To all whom it may concern:*

Be it known that I, MARCUS H. ROGERS, of Great Barrington, in the county of Berkshire and State of Massachusetts, have invented a new and Improved Newspaper-Folding Machine, of which the following is a specification:

Figure 1 is a plan view, with parts broken away to show the construction more clearly. Fig. 2 is a front elevation taken in section on line *x x* in Fig. 1. Fig. 3 is a detail view of the gearing for moving the first folding-knife. Fig. 4 is a vertical section taken on line *y y* in Fig. 1. Fig. 5 is a detail view of one of the knife-actuating cams.

My invention relates to the class of machines that are employed in folding newspapers for mailing.

The invention will first be described in connection with the drawing, and then pointed out in the claims.

Similar letters of reference indicate corresponding parts.

Referring to the drawings, A is the frame which supports the several parts of the machine. In the upper portion of this frame two rollers, B B', are journaled a short distance from the center of the frame. These rollers are nearly in contact with each other, and project a small distance above the top of the frame. Upon the top of the frame A there is a table, made in two sections, *a b*, *a* at its inner edge and under side being concaved to conform to the roller B, and the section *b* being similarly concaved to conform to the roller B', both sections being in the same plane and level with the top of the rollers B B'.

There are a number of slots, *c c*, in each section of the table, which are arranged at right angles to the rollers B B'.

The section *b* is provided with gage-pieces *d e*, that are arranged at right angles to each other, and are adapted to receive the corner of the paper as it is delivered from the fly of the printing-press.

Tapes *f* pass around the roller B and under the roller B', and are supported in a horizontal position by rollers *g*, journaled in the side of the frame A.

Under the section *a* of the table a rocking shaft, C, is journaled, to which two arms, *h*, are attached one at each end. These arms extend upward through the space between the ends of the table-section *a* and the side pieces of the frame A, and carry a folding-knife, D, which is parallel to the rollers B B', and is capable of striking between the said rollers when actuated by mechanism which will presently be described.

The tapes *f* are arranged in two series, there being three tapes in each series. Between the two series of tapes two rollers, E E', are journaled in the frame A at right angles to the rollers B B', and with their upper surfaces in the same plane with the upper surface of the tapes.

A folding-knife, F, is supported above the space between the rollers E E' by arms *i*, which are attached to a rocking shaft, *j*, journaled in the frame A parallel to the rollers E E'.

The shaft *j* is provided with an arm, K, which is bent at right angles near its free end, and rests upon a cam, *l*, on the driving-shaft H.

Below and parallel to the rollers E E' two rollers, G G', are journaled in an inclined plane, and tapes *o* run over the roller E and pass under the roller E', and run over the roller G and under the roller G', and forward in a horizontal plane around guide-rollers *m*, journaled in the front portion of the main frame. The lower portion of the tape is prevented from coming into contact with the rollers G G' by a guide-roller, *m'*.

Above the space between the rollers G G' a folding-knife, *p*, is supported by arms *g*, that are attached to the rocking shaft *r*, which is journaled in the main frame parallel to the rollers, G G', and is provided with an arm, *s*, whose rearwardly-projecting end is bent at right angles and rests upon a cam, *t*, on the driving-shaft H. Below the rollers G G' two rollers I I', are journaled in the frame A at right angles to the rollers G G', and with their upper surfaces in the same plane with the tapes *o* below the roller G'. Above and parallel to the rollers I I' a folding-knife, J, is supported by arms *u* that are attached to the rock-shaft V.

On each side of the rollers I I' there is an adjustable stop, which consists of the fixed horizontal arm *w* and the upright piece *a'*. Above the tapes *o* fingers *b'* are supported by the bar *c''*, which is secured to cross-bars in the frame A. These fingers, in conjunction with the upright pieces *a'*, prevent the partly-folded paper from being raised with the folding-knife *p*.

The main shaft H takes its motion from the cylinder-shaft of the printing-press in connection with which the folder is used, by means of a chain-belt, which runs on the chain-wheel *d'*, which is loosely placed on the shaft H. The boss of this chain-wheel is provided with a finger, *e'*, that extends over the boss of the spur-wheel *f'*, secured to the shaft H. A lug, *g'*, projects from the boss of the spur-wheel *f'* in position to be engaged by the finger *e'*. By means of this device the press may be turned backward, when required, through the greater portion of a revolution without moving the folding-machine, and when the press is turned forward the folding-machine will register correctly.

The roller E takes its motion from the spur-wheel *f'* by a pinion, *h'*, and a similar pinion, *h<sup>2</sup>*, is placed on the shaft of the roller E', which meshes with the pinion *h'* and causes the two rollers to rotate together.

By means of miter-wheels *i'* motion is imparted by the shaft H to a shaft, M, which is journaled in the frame A at right angles to the shaft H and parallel with the rollers B B'. Upon the front end of the shaft M a spur-wheel, N, is secured, which meshes into a pinion, *j'*, on the shaft of the roller B.

The rollers I I' are geared together, each being provided with a pinion, *k'*, and they receive motion from the spur-wheel N through the intermediate wheels O P, which turn on studs that project from the front of the frame A. On the shaft M a disk, Q, is secured, which carries a roller, *e'*, that works in an oblong aperture in the arm *m<sup>2</sup>* that is attached to the rock-shaft *v*. On the shaft M two mutilated gear-wheels, *n' o'*, are secured. The mutilated wheel *o'* engages a similar mutilated wheel, *p'*, on the rock-shaft C at the proper instant to throw the folding-knife D toward the rollers B B' after the paper has been deposited on the folding-table by the fly of the printing-press.

The return of the knife D is secured by the mutilated wheel *n'*, which engages a rack, *q'*, that is supported in an inclined guide, *r'*, and engages the spur-wheel S' on the rock-shaft C.

In the base of the frame A there is a table, R, which is arranged at right angles to the rollers I I', and is provided with two guides for receiving the base-piece *t'* of the packer S. The base-piece *t'* is connected by a connecting-rod, *u'*, with an arm, *v'*, that projects downward from the rock-shaft *v*. By means of this arrangement the packer S is drawn quickly back to receive the folded paper delivered by

the rollers I I', and the paper is pushed slowly forward against the follower T.

The table of the folding-machine takes the place of the usual paper-receiving table of the printing-press, and the papers are delivered to the apertured table of the folding-machine by the fly of the press, this operation being facilitated by apertures *e*, which permit the air to escape from underneath the paper as the paper is carried by the fly.

The folding-machine registers with the printing-press with which it is connected, so that as the fly leaves the paper on the folding-table the knife D is brought over on the middle of the table, causing it to enter between the rollers B B', by which it is carried downward. As it passes through the rollers B B' it is carried on the tapes *f* until it strikes the gage-fingers, supported by the bar A'. This bar is adjusted by means of the screws B'', so as to adapt the folder to papers of different sizes; or it may be held by notches made at intervals in the side pieces that hold the guide-bar, and the bar may be adjusted by shifting it from one notch to another. The notched side pieces may in this case be adjusted by screws.

The rollers E E' are so arranged in relation to the rollers B B' that the center of the folded paper comes over the space between the rollers E E' and under the folding-knife F. As soon as the paper comes to rest the folding-knife F drops, carrying the fold of the paper between the rollers E E'.

The paper is carried downward by these rollers and delivered to the tape *o*, by which it is carried over the rollers G G' until it strikes the stop *a'*, when the folding-knife *p* drops and makes a fold which is parallel to the fold last made. The paper is now carried forward by the tapes *o* and supported by them until it is forced between the rollers I I' by the folding-knife J. It is carried downward by the rollers I I', which complete the final fold and deliver the paper to the table R in front of the packer S.

As soon as the folded paper strikes the table the packer is moved forward by the means already described, and returns to receive another folded paper.

The weight of the folding-knives will generally be found sufficient to effect the folding of the paper; but should it be found insufficient a spring may be applied, as shown in Fig. 5.

It is obvious that a table composed of slats or bars may be employed instead of the apertured table, as described.

The advantages claimed for this machine are that it may be placed under the fly of an ordinary power printing-press, and it may be used in conjunction with the press, folding the papers as fast as they are printed.

Having thus fully described my invention, I claim as new and desire to secure by Letters Patent—

1. The mutilated wheels *n' o'*, carried by

shaft M, the mutilated wheel  $p'$ , spur-wheel  $s'$ , and rack  $q'$ , in combination with the folding-blade, for imparting to the folding-knife D an intermitting oscillatory motion, substantially as herein shown and described.

2. The roller  $l'$  carried by the shaft M, and the apertured arm  $m^2$  and rock-shaft V, in

combination with the folding-knife J and packer S, substantially as herein shown and described.

MARCUS HARMON ROGERS.

Witnesses:

R. N. COUCH,

FRANK DURANT.