

L. L. SHAW.
Warping-Machine.

No. 205,307.

Patented June 25, 1878.

Fig. 1.

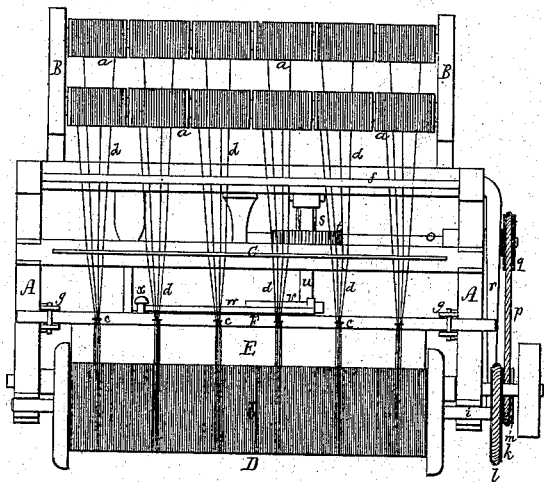

Fig. 2.

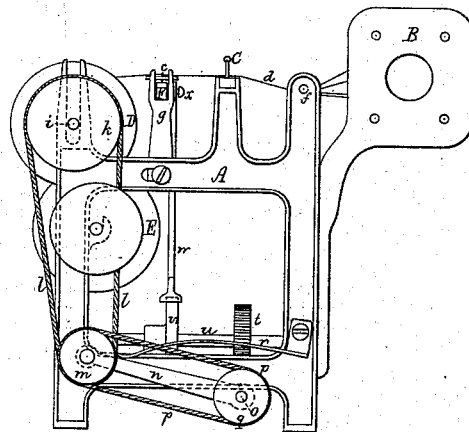

Fig. 4.

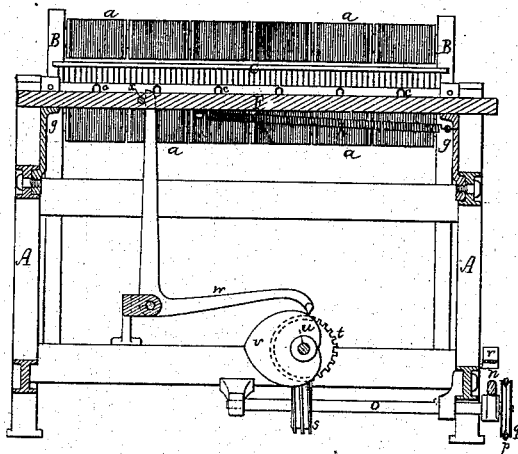
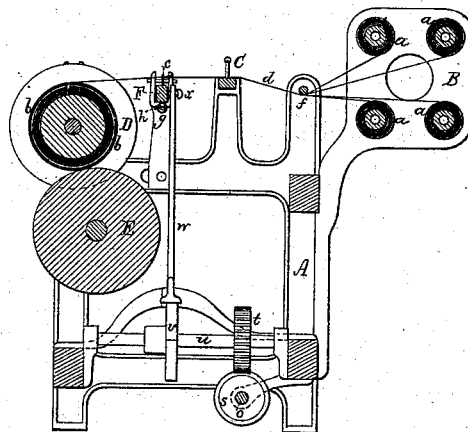

Fig. 3.



Witnesses

S. W. Piper.

L. W. Miller.

Inventor

Lorenzo L. Shaw.

by his attorney.

R. H. Eddy

UNITED STATES PATENT OFFICE.

LORENZO L. SHAW, OF YARMOUTH, MAINE.

IMPROVEMENT IN WARPING-MACHINES.

Specification forming part of Letters Patent No. 205,307, dated June 25, 1878; application filed February 18, 1878.

To all whom it may concern:

Be it known that I, LORENZO L. SHAW, of Yarmouth, of the county of Cumberland and State of Maine, have invented a new and useful Improvement in Machinery for Beaming Yarn or Winding Yarns upon a Beam or Roller; and do hereby declare the same to be described in the following specification and represented in the accompanying drawings, of which—

Figure 1 is a top view, Fig. 2 an end elevation, Fig. 3 a transverse section, and Fig. 4 a longitudinal section, of a machine embodying my invention, the object of which is to lay or wind the yarns in strands or separate series upon the beam, and to accomplish such evenly as the load of the beam may increase in diameter.

In the common warpers or yarn-beaming machines the threads from the spools are led in one series from the reed to the beam; but in my machine, as hereinafter described, they are separated, and pass in several series from the reed through a set of traversing guides, and thence to the beam, whereby while it may be in revolution they are wound in strands upon it, each of which is laid in helices about the beam, and with the coils of each helix close together. The object of thus laying the yarns upon the beam is to enable them to be conveniently unwound therefrom, for being spun or converted into twisted strands.

In the drawings, A denotes the frame of the machine; B, a creel or stand, provided with the series of spools *a a a*. C is the reed; D, the yarn-beam, and E its supporting and operative cylinder or roller. The load *b* of the beam rests directly upon the circumference of the roller E, which, when the machine is in operation, is revolved at a uniform speed, and consequently causes the load-surface resting on it to revolve at a like speed, however the load may increase in diameter.

Between the reed and the yarn-beam D is a traversing bar, F, provided with a series of staples, eyes, or reducing-guides, *c c c*, arranged at equal distances apart, each of them being adapted to receive through it four, or any other suitable number, of the yarns *d* from the reed, such yarns being first led from the

spools to and under and against a guide-rod, *f*, and thence to and through the reed.

The traversing bar is supported in Ys or standards *g g*, to which it is to be so applied as to enable it to be moved lengthwise or traversed therein. For retracting it or moving it backward, it has a spring, *h*, fixed to it and to one of the standards *g*; but for moving it in the opposite direction, there is applied to it and to the shaft of the yarn-beam mechanism which may be thus described: Fixed on the shaft *i* of the yarn-beam D is a grooved wheel, *k*, about which and a double-grooved wheel, *m*, an endless band, *l*, is led. This wheel *m* is pivoted to an arm *n*, that is pivoted on a shaft, *o*, arranged as represented. Another endless band, *p*, engages the wheel *m* with a grooved wheel, *q*, fixed on the shaft *o*. There is a spring, *r*, fastened to the frame, and bearing downward the arm *n*, in order to keep the belt *l* tight on its pulleys or wheels and allow the yarn-beam to rise as its load may increase in size.

A worm or endless screw, *s*, fixed on the shaft *o*, engages with a worm-gear, *t*, fastened on a cross-shaft, *u*, arranged as shown, and provided with a heart-cam, *v*, upon whose periphery the lower arm of an angular lever, *w*, rests. The upper arm of the said lever bears against a stud, *x*, extending from the traverse-bar F.

From the above it will be seen that, while the yarn-beam may be in revolution, a slow reciprocating rectilinear motion will be imparted to the said traversing bar, whereby the strands will be caused to be laid or wound evenly and properly on the beam. As the load on the beam may increase in diameter the rotary motion of the beam will become less or slower, whereby the traversing movements of the bar F will be correspondingly or so decreased in velocity as to cause the strands to be laid in even or close helices and layers on the beam.

Thus, by driving the traversing-bar mechanism by the yarn-beam, the velocity of traverse of the bar F becomes decreased as the velocity of the beam may diminish in consequence of the increase of the size or diameter of the load of yarn wound on the beam. By revolving

the roller on which the beam-load rests, the latter will be put in revolution, so as to cause the yarns to be drawn off the spools and wound on the beam or load thereof.

What I claim as my invention or improvement in the yarn-beaming machine is as follows, that is to say:

1. In combination with the reed C, the yarn-beam D, and its supporting and operative roller or cylinder E, the traversing bar F, its series of reducing-guides *c*, and the mechanism applied to the said bar and to the shaft of the yarn-beam, and consisting of the grooved wheels *k m q*, endless bands *l p*, arm *n*, springs *r h*, shafts *o u*, worm *s*, worm-gear *t*, heart-cam *v*, and lever *w*, arranged and applied as set forth, it being for moving the trav-

ersing bars with a variable reciprocating motion in accordance with the variable rotary motion of the beam as the load of the latter may increase in diameter.

2. The combination substantially as described, applied to the traversing bar and to the yarn-beam for moving the former by the latter, as specified, it consisting of the grooved wheels *k m q*, endless bands *l p*, arm *n*, springs *r h*, shafts *o u*, worm *s*, worm-gear *t*, heart-cam *v*, and lever *w*, arranged and applied as represented.

LORENZO L. SHAW.

Witnesses:

R. H. EDDY,
JOHN R. SNOW.