

G. BLATCHFORD.
Reed-Organ.

No. 205,341.

Patented June 25, 1878.

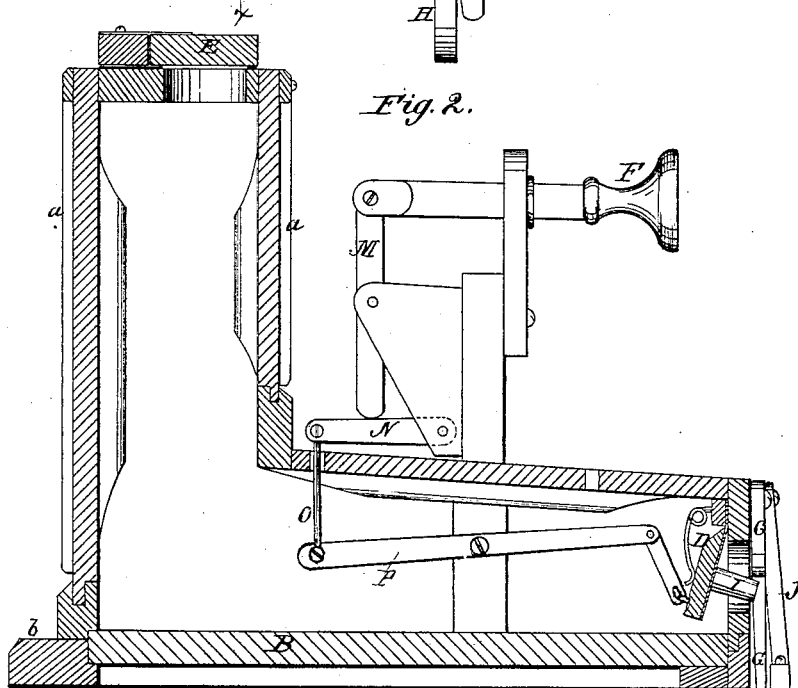
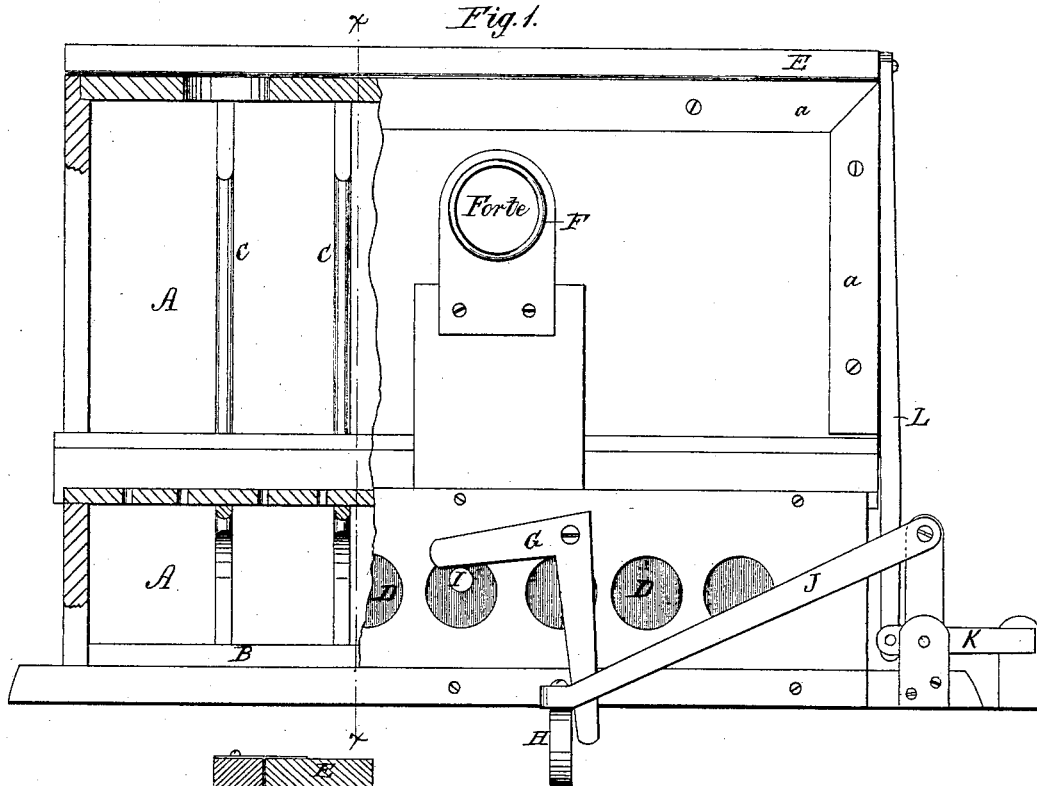

WITNESSES:

W. W. Hollingsworth
John Kemon

INVENTOR:

Geo. Blatchford

BY

Wm. G.

ATTORNEYS.

UNITED STATES PATENT OFFICE.

GEORGE BLATCHFORD, OF MITCHELL, ONTARIO, CANADA.

IMPROVEMENT IN REED-ORGANS.

Specification forming part of Letters Patent No. **205,341**, dated June 25, 1878; application filed April 26, 1878.

To all whom it may concern:

Be it known that I, GOERGE BLATCHFORD, of the town of Mitchell, in the county of Perth and Province of Ontario, Dominion of Canada, have invented a new and Improved Resonant-Chamber for Organs; and I do hereby declare that the following is a full, clear, and exact description of the same, reference being had to the accompanying drawing, forming part of this specification, in which—

Figure 1 represents a sectional front elevation of my improved resonant-chamber for cabinet-organs; and Fig. 2, a vertical transverse section of the same on line *x x*, Fig. 1.

Similar letters of reference indicate corresponding parts.

This invention has reference to such improvements in my resonant-chamber for organs as will produce a more distinct and perfect vibration of the chamber; also, a more solid and distinct volume of sound; and, lastly, a more perfect control of the sounds produced, so as to produce or bring out a crescendo or diminuendo at will and with less effort.

This invention consists of the following improvements on my resonant-chamber secured by Patent No. 169,945. First, in inserting the reed-board into grooves inside of the chamber, instead of supporting the chamber from the reed-board; secondly, in placing solidifying or qualifying bars on the inside of the chamber; thirdly, of an additional swell at the front of the horizontal section of the chamber; and, fourthly, in mechanism for operating the two swells, as will be hereinafter more fully described.

In the drawing, A represents my resonant-chamber, which consists of a horizontal and a vertical section, joined at right angles to each other, the reed-board B being inserted in the grooves inside, as hereinbefore mentioned. The object secured by this change of the positions of the reed-board is that a more perfect vibration of the chamber is thereby obtained.

The chamber A is provided with the solidifying or qualifying bars C, arranged at the inside of the horizontal part, as well as on the vertical face and back of the chamber.

At the front of the horizontal section of the chamber is arranged the swell D, which may be operated either in combination with the

grand swell E by the knee-stop lever, or independently of the grand swell E by means of the draw-stop F, as the performer desires. The swell D is attached by a hinge to the upper part of the front of the chamber, on the inside, so as to open inward. When operated in combination with the grand swell E, it is operated by the lever G, which is in form of a square, attached to the front of the chamber by means of a screw. The vertical arm of the lever G passes down to the right of the knee-stop H, while the horizontal arm rests on the pivot I, which passes from the swell D through one of the perforations in the chamber. When the swell D is operated by the draw-stop F independently of the grand swell, the pivot I falls below the reach of the arm of the lever sufficient to allow independent action. From the knee-stop H an inclined lever, J, passes in front of the chamber to the vertical arm of the horizontal lever K, which passes from front to rear at the right of the chamber, and which is pivoted to supports from what is usually called the "tray" of the air-chamber. A horizontal arm is placed near the back end of lever K, extending toward the end of the resonant-chamber, to which is attached by means of a screw a vertical lever, L, the top end of which is attached to the grand swell E, and which is operated by pressing the knee-stop to the right, and returning automatically to its resting position.

The draw-stop F is attached to a semi-vertical lever, M, which is pivoted in the center, under the end of which is a semi-horizontal lever, N, pivoted at the front end; and when the draw-stop F is drawn forward, the lower end of the semi-vertical lever M passes back on said semi-horizontal lever N, causing it to stand in a horizontal position. A rod, O, attached to the back end of said lever N, passes through the chamber, the lower end of which is attached to another horizontal lever, P, inside of the chamber, which lever P is pivoted near the center, the front end being attached by a leather-strap attachment to the lower edge of the swell D. The swell is held in position when closed by means of wire springs, the lever being depressed at the back end simultaneously with the depression of lever N, which raises the front end of said lever P, by which

the swell D is opened by the leather-strap attachment, as hereinbefore mentioned.

The grand swell E is narrowed and the perforated part raised to a level with the face and back walls of the vertical-chamber section. This change gives the same effect as in Patent No. 169,945, but with a simplification in the construction of the same.

The chamber A is strengthened at the outside of the vertical face and back walls with straps *a*, to prevent springing of the sides or opening of the joints.

The action is fastened to the outer rim *b* formed around the resonant air-chamber, and consists of reed-board, key-board, valves, &c., which are all built in and above the resonant-chamber bottom, and form together the complete organ-action.

Having thus described my invention, what I claim as new is—

1. A resonant air-chamber for organs having the reed-board inserted into grooves inside of

the chamber, so as to obtain a more perfect vibration of the chamber, substantially as and for the purpose set forth.

2. A resonant air-chamber for organs made of a horizontal and a vertical section, having solidifying or qualifying bars to obtain a more distinct voicing of the instrument, substantially as specified.

3. In combination with a resonant-chamber for an organ, an auxiliary front swell, in connection with or independently of the grand swell at the top of the chamber, substantially as described.

4. The combination of the knee-stop H, lever G, pivot I, and levers J, K, L, M, and N, rod O, lever P, and leather-strap attachment, substantially as and for the purposes set forth.

GEORGE BLATCHFORD.

Witnesses:

JOHN L. MACLEAN,
DANIEL MCPHAIL.