

C. H. BLISS.  
 Device for Holding and Delivering Coin.  
 No. 205,343.                      Patented June 25, 1878.

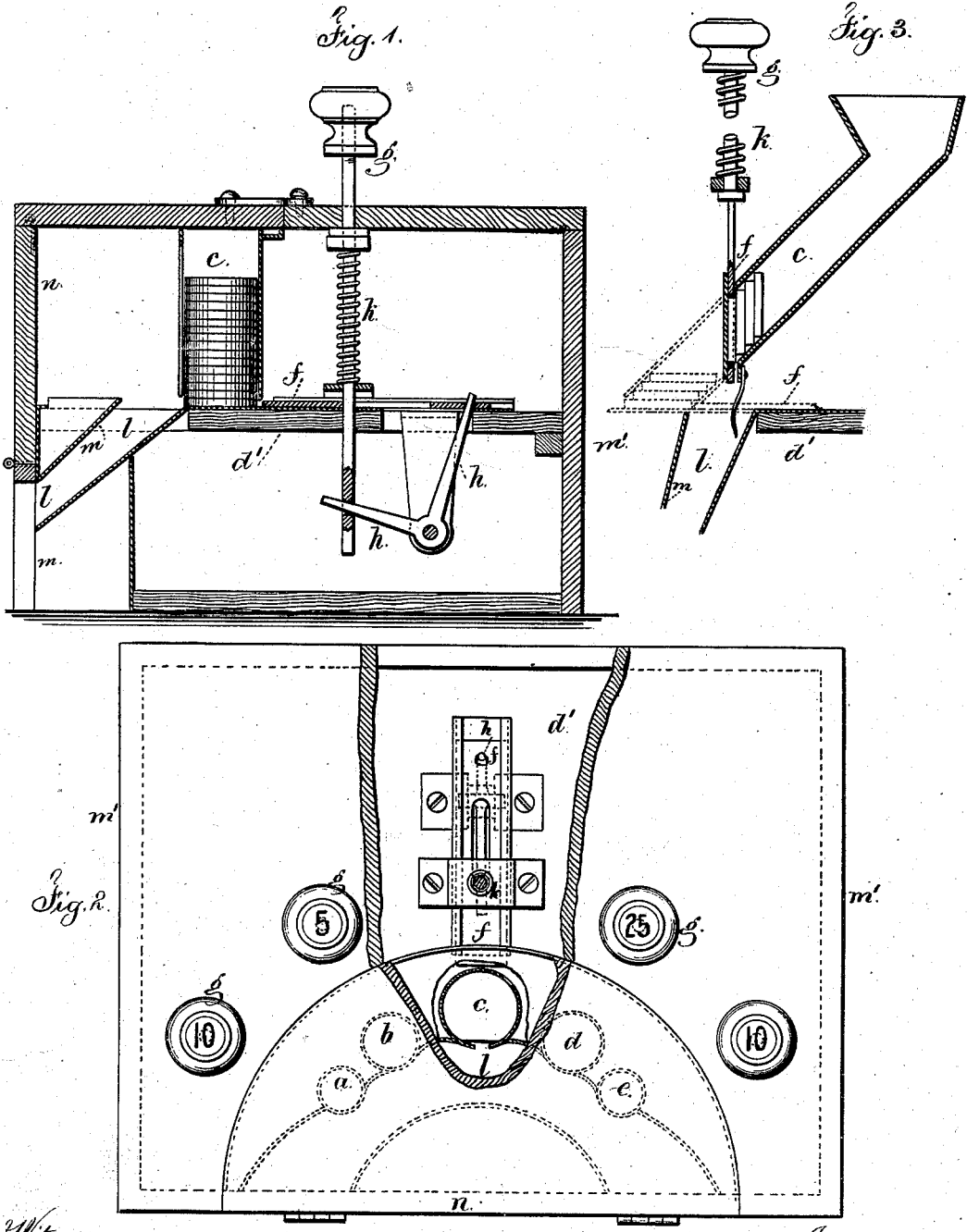

Witnesses  
 Chas. H. Smith  
 Geo. T. Prickney

Inventor  
 Charles H. Bliss.  
 per Lemuel W. Perrell att

# UNITED STATES PATENT OFFICE.

CHARLES H. BLISS, OF ROCHESTER, MINNESOTA.

## IMPROVEMENT IN DEVICES FOR HOLDING AND DELIVERING COIN.

Specification forming part of Letters Patent No. **205,343**, dated June 25, 1878; application filed April 19, 1878.

*To all whom it may concern:*

Be it known that I, CHARLES H. BLISS, of Rochester, in the State of Minnesota, have invented an Improvement in Coin-Holders, of which the following is a specification:

The object of this invention is to facilitate the making of change, and to allow for the coins being secured within holders adapted to the different values.

I provide a series of coin-holders, each in a tubular form, of a size adapted to receive the particular coin in a pile, and these coin-holders are, either in a vertical, inclined, or horizontal position, arranged around a funnel-mouth, and to each coin-holding tube there is a slide operated by a push-button that is located by preference above the holder. By pressing upon one of these buttons the bottom coin in the pile is moved out laterally and falls into the funnel-mouth and passes to the hand that is placed beneath such mouth. The slide is slightly thinner than the coin that is to be moved by it, and the push-button is marked with the denomination of the coin with which it is employed.

In the drawing, Figure 1 is a vertical section of the holder. Fig. 2 is a plan of the same, partially in section.

The coin-tubes *a b c d e* are of various diameters, adapted to the particular coins, such as five-cent pieces, dimes, quarter-dollars, &c., and there may be any desired number of these tubes, according to the capacity of the coin-holder, and each tube should be provided with a longitudinal slot that allows the coins to be examined or adjusted in cases where any may be misplaced as the pile of coin is dropped into the tube.

The coin-tubes are supported by a bed-plate, *d'*, and there is a stop at the end of each tube, and a sufficient space between the stop and the end of the tube for the bottom or end coin of each pile to be pushed out laterally, and to each coin-tube there is a horizontal slide, *f*, of slightly less thickness than the coin, and said slide is moved by the action of the push-button *g*, and it carries the end coin from the pile when the push-button is operated. The spring *k* serves to raise the push-button and restore the parts to their normal position.

The bent levers *h* are employed with the horizontal slides.

These coin-holding tubes may be placed vertically, as shown, or it may be at an inclination, the slides acting horizontally, or the coin-tubes might be horizontal with a spring to force the pile toward the stop. In this case the slide will be vertical. I, however, prefer the tubes either vertical or at an inclination.

Fig. 3 illustrates the inclined coin-holding tubes, and represents the manner in which the slides may be placed vertically to detach the lowest coin in the inclined pile.

If the slide is to be operated horizontally the tubes will terminate as shown by dotted lines. In either instance the coins can be poured into the funnel end of the tube, and will arrange themselves either vertically or horizontally, according to the stop at the end of the tube.

The coin-holding tubes are arranged semi-circularly, or nearly so, by preference, in order that the coins may be delivered toward a common center, at which there is a funnel or crescent shaped mouth, *l*, with a central deflector, *m*, so that the coins are discharged by their respective push-buttons and slides, and fall through the mouth *l* into the person's hand placed beneath the mouth.

It will be apparent that the coins are kept in their proper position, and that the computation of change is greatly facilitated by this instrument, and risk of errors is lessened.

A suitable inclosing-case, *m'*, should be provided, having a movable front, *n*, that can be opened or closed to give access to, or to shut in, the coin-holding tubes.

I am aware that vertical slotted cylinders have been used for holding coin, and that slides have been provided for delivering the bottom coin in either tube. By my arrangement of slides and delivery-funnel I am enabled to place numerous coin-holders in an arc of a circle around the funnel, and deliver the coins in the line of the radius of the arc, or nearly so, which greatly facilitates the reception of the coins at one point in the hand.

I claim as my invention—

1. The range of coin-holding tubes in the arc of a circle, or nearly so, in combination

with a funnel-shaped mouth for receiving the coins from any of the holding-tubes and discharging the same at one place, substantially as set forth.

2. The combination, with the coin-holding tubes, of the horizontal slides *f*, acting to push the coin out from the pile, the push-buttons *g* and their vertical rods, and the bent

levers *h* and springs *k*, arranged and operating substantially as set forth.

Signed by me this 5th day of April, A. D. 1878.

CHARLES H. BLISS.

Witnesses:

T. H. BLISS,

JOHN T. LA DU.