

F. HOLUB.
Machine for Manufacturing Horseshoe Blanks.

No. 205,385.

Patented June 25, 1878.

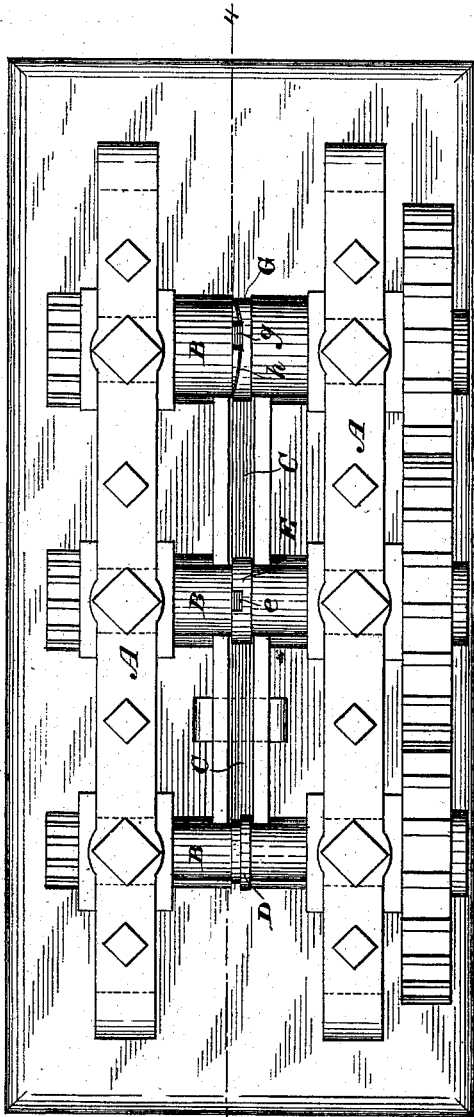

Fig. 1.

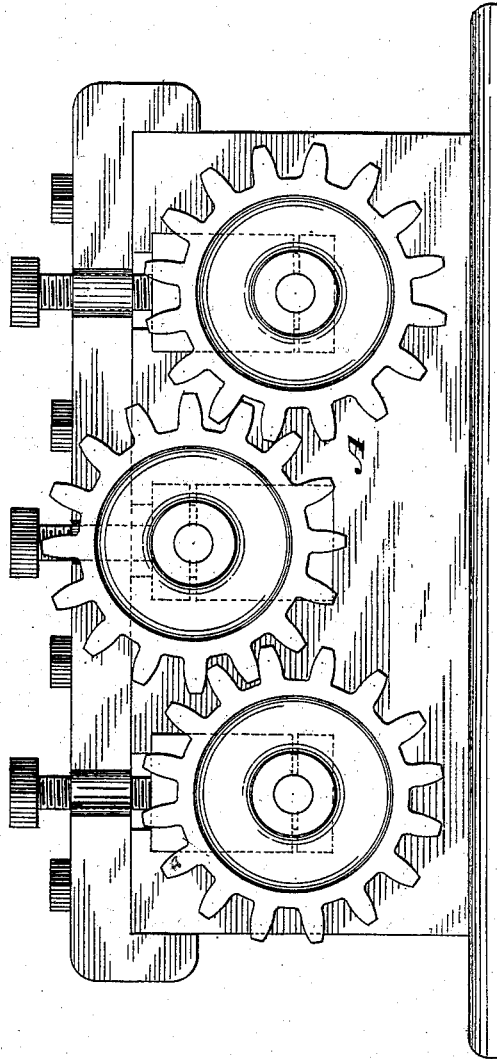

Fig. 2.

WITNESSES

Wm A. Skinkle,
Geo W Breck.

INVENTOR

Frank Holub,

By his Attorneys

Baldwin, Hopkins, & Peyton

F. HOLUB.
Machine for Manufacturing Horseshoe Blanks.
No. 205,385. Patented June 25, 1878.

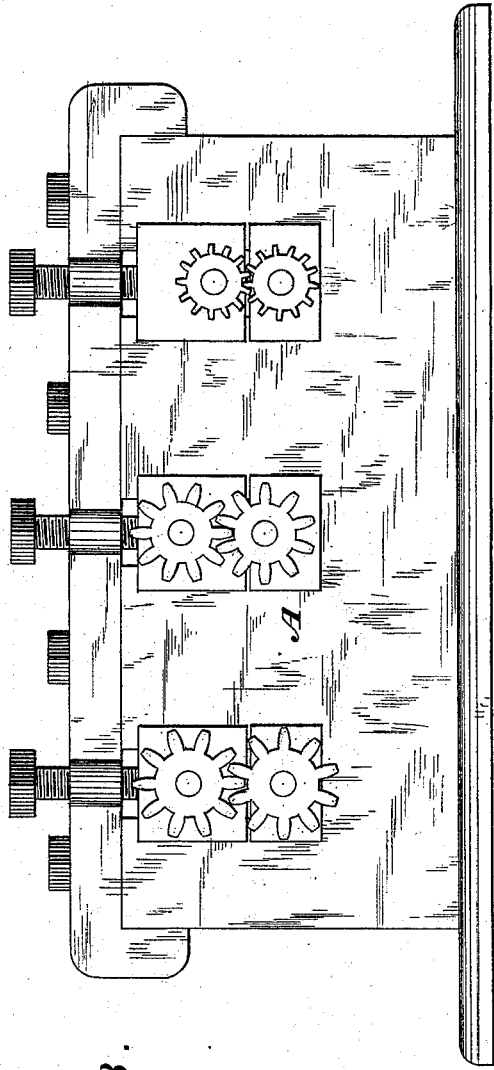

Fig. 3.

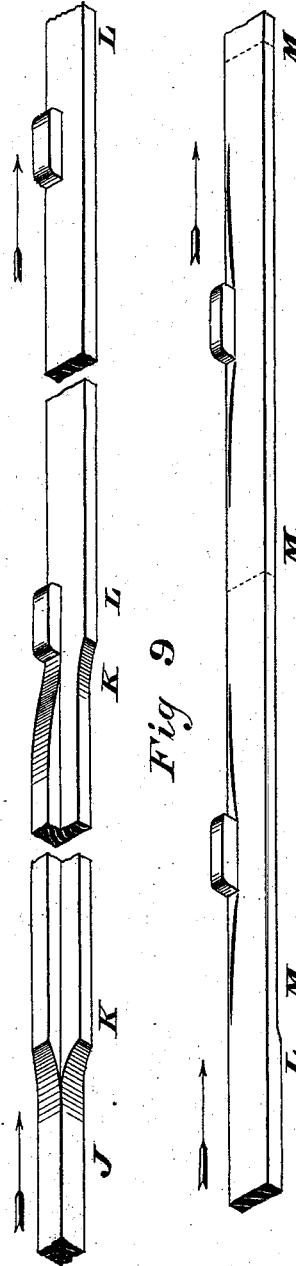

Fig. 8.

Fig. 9.

WITNESSES

Wm A. Shinkle
Geo W. Breck

INVENTOR

Frank Holub.
By his Attorneys
Baldwin, Hopkins, & Peyton

F. HOLUB. Machine for Manufacturing Horseshoe Blanks.

No. 205,385.

Patented June 25, 1878.

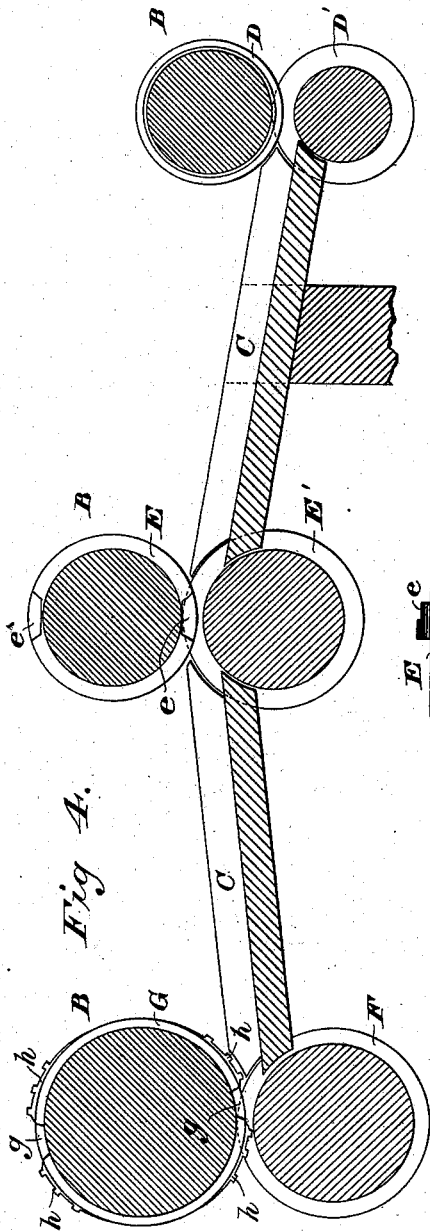

Fig A.

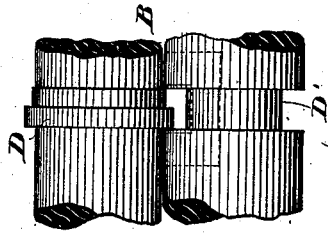

Fig 5.

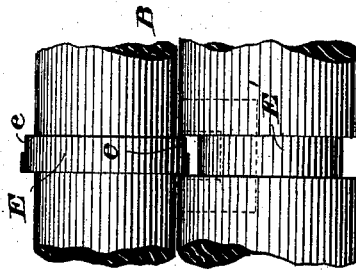

Fig 6.

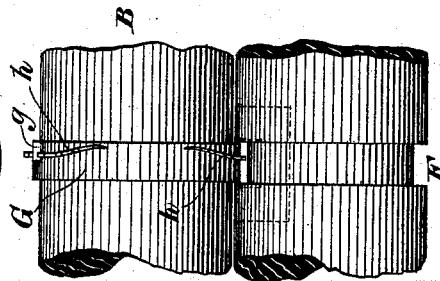

Fig 7.

WITNESSES

Wm A Shankle
Geo W Beck.

INVENTOR

Frank Holub.

By his Attorneys

Baldwin, Hopkins, & Peyton

UNITED STATES PATENT OFFICE.

FRANK HOLUB, OF CHICAGO, ILLINOIS, ASSIGNOR OF TWO-THIRDS HIS RIGHT TO NATHAN E. PLATT AND EDWIN THORN, OF SAME PLACE.

IMPROVEMENT IN MACHINES FOR MANUFACTURING HORSESHOE-BLANKS.

Specification forming part of Letters Patent No. **205,385**, dated June 23, 1878; application filed June 15, 1878.

To all whom it may concern:

Be it known that I, FRANK HOLUB, of Chicago, in the county of Cook and State of Illinois, have invented an Improved Machine for Manufacturing Horseshoe-Blanks, of which the following is a specification:

The object of my invention is to form a series of horseshoe-blanks by passing a heated bar through a train of three sets of rolls, one set behind the other, at a single operation and with a single heating of the bar.

My invention consists in the formation of the dies upon the rolls in a suitable manner for successive operation upon the bar, and in their combination with one another and with suitable guideways, to constitute a horseshoe-blank-forming machine.

In the accompanying drawings, Figure 1 represents a plan view of my machine; Fig. 2, a side elevation; Fig. 3, a similar elevation on the opposite side; Fig. 4, a vertical longitudinal section through the rolls and guideways on the line 4 4 of Fig. 1; Figs. 5, 6, and 7, side elevations of the different sets of rolls; and Figs. 8 and 9 are perspective views of the bar and blanks in different stages of formation.

A indicates a roller-frame of any ordinary construction; B B B, ordinary heavy sets of rolls, with suitable gearing for operating them; and C C, trough-shaped guideways between the sets of rolls, for directing the bar from the first set to the second, and from the second set to the third.

D indicates the first forming-die, working in the groove D' of the first set of rolls. The heated bar is passed into this groove and under the die while the machine is in motion, and is conveyed by the guideway to the second set of rolls, provided with the die E and groove E'. The die E is provided with two or more depressions, *e*, of a distance apart corresponding to the length of the individual blanks to be formed by that die. These depressions are for the purpose of swaging up a projection upon the center of each blank, to constitute the toe-calk, as illustrated in the drawings.

From the second set of rolls the partially-formed series of blanks in the bar passes to

the third set, and enters between the groove F and the die G to be finished. Die G is provided with depressions *g*, for finishing the swaging of the toe-calks, and with creasers and punches *h*, for forming the creases and nail-holes in the blank, as is well understood in the art.

The bar J, after having passed through the first set of rolls, is given the conformation shown at K K in Fig. 8. After having passed through the second set of rolls it is given the conformation shown at L L in Figs. 8 and 9, and after having passed through the third set of rolls it is given the finished conformation shown at M M in Fig. 9, having the toe-calk fully developed, and the creases and nail-holes.

The sets of rolls are so adjusted with reference to one another, and their gearing is so calculated and constructed, that the dies upon the second and third sets will register properly on the blank as it enters them, so as to prevent waste of stock and to carry out the formation of the blanks accurately from the beginning, the last set of dies registering on the blank properly as it comes from the second set.

If I wish to form a series of blanks without toe-calks, I can employ collars or dies without the depressions *e* and *g*, but in other respects of the form illustrated in the drawings.

By passing the bar through the third set of rolls after it has passed through the first and second sets, I am enabled to produce a finished toe-calk, projecting the proper distance from the bottom of the shoe, which cannot be accomplished by a single swaging operation.

What I claim as new, and desire to secure by Letters Patent, is—

The three sets of rolls provided, respectively, with forming-dies and grooves, as described, in combination with the guideways between them and with one another, for forming a series of blanks from a heated bar at a single operation, substantially as described.

In testimony whereof I have hereunto subscribed my name.

FRANK HOLUB.

Witnesses:

MARCUS S. HOPKINS,
F. STITH.