

G. KEMMEL.
Automatic Wagon-Brake.

No. 205,396.

Patented June 25, 1878.

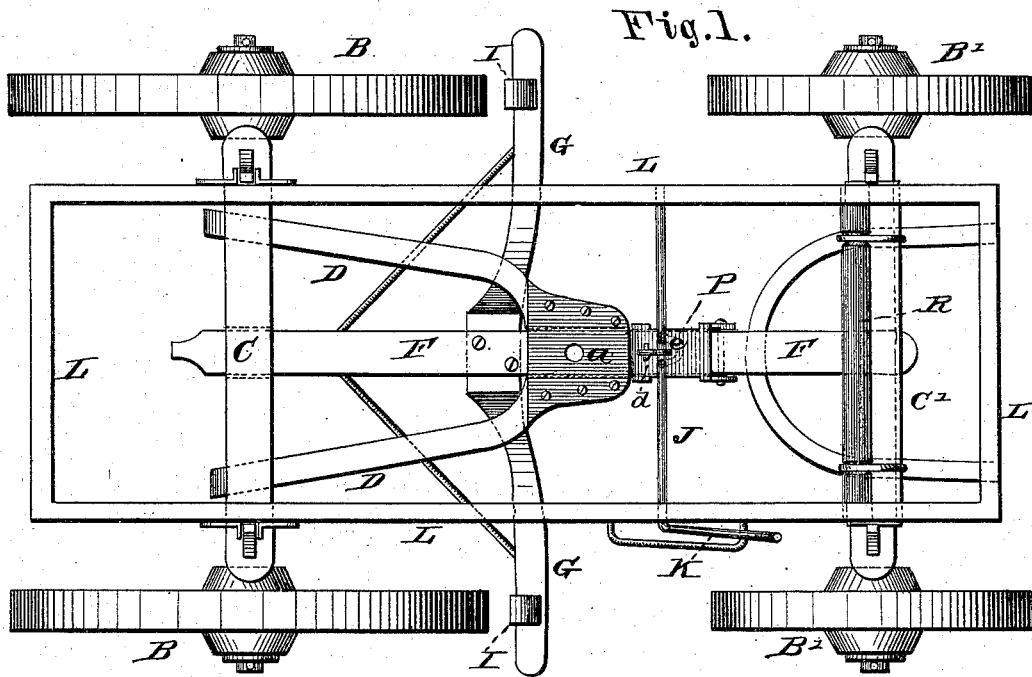
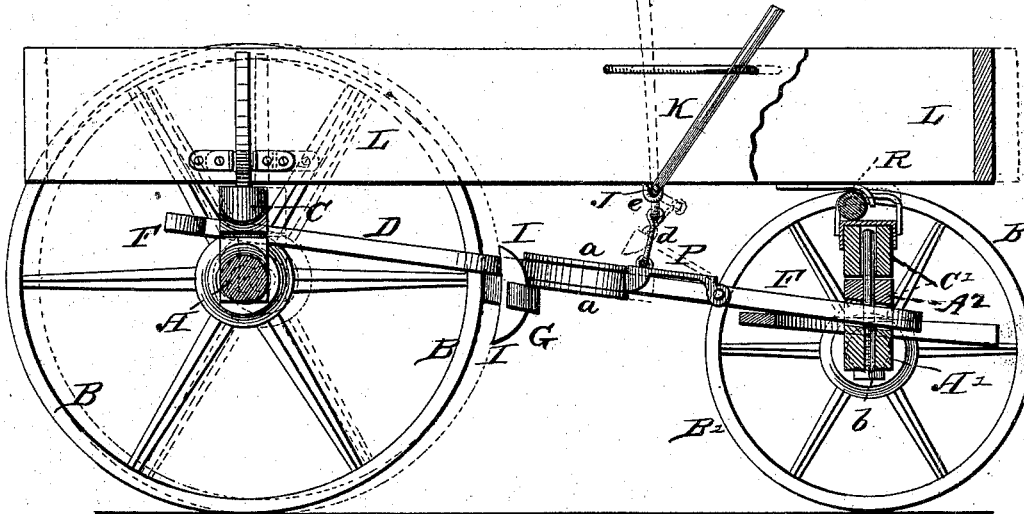
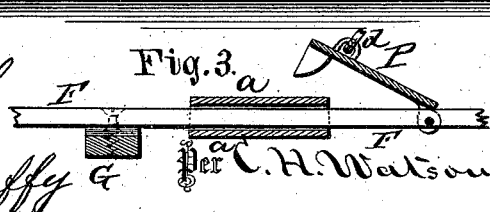

Fig. 2.



Witnesses:
P. A. Dietrich
Frank H. Duffey &



Inventor:
Gottlieb Kemmel
Per *C. H. Watson & Co.* Attorneys.

UNITED STATES PATENT OFFICE.

GOTTLIEB KEMMEL, OF SUMMIT, MICHIGAN.

IMPROVEMENT IN AUTOMATIC WAGON-BRAKES.

Specification forming part of Letters Patent No. 205,396, dated June 25, 1878; application filed May 28, 1878.

To all whom it may concern:

Be it known that I, GOTTLIEB KEMMEL, of Summit, in the county of Jackson and State of Michigan, have invented certain new and useful Improvements in Wagon-Brakes; and I do hereby declare that the following is a full, clear, and exact description thereof, which will enable others skilled in the art to which it appertains to make and use the same, reference being had to the accompanying drawings, and to the letters of reference marked thereon, which form a part of this specification.

The nature of my invention consists in the construction and arrangement of a self-acting wagon-brake, as will be hereinafter more fully set forth.

In the annexed drawing, which fully illustrates my invention, and to which reference is made, Figure 1 is a plan view, Fig. 2 is a side elevation, partly in section, and Fig. 3 is a detail view, of my invention.

A represents the rear axle, with a wheel, B, on each end. On top of the rear axle A is the bolster C, and the hounds D D project forward from said rear axle, and have their front ends connected by top and bottom plates or castings *a a*, as shown.

A¹ is the front axle, with sand-board A² and wheels B' B'. C' is the front bolster, connected to the sand-board and front axle by the king-bolt *b*.

F represents the reach, having its front end connected between the front axle and sand-board by the king-bolt *b*, as shown, and extending rearward between the front ends of the hounds D D, and through a slot or opening made in the hind axle A and bolster C, so as to slide back and forth therein, as required. To the reach F is secured the brake-bar G, to which the shoes I I are secured in proper position to be applied on the front of the hind wheels B B, said brake-bar being braced in suitable manner to the reach, so as to be kept perfectly firm and rigid on the same.

It will readily be seen that in going downhill, or whenever the team is held back, the reach F will slide backward and apply the brakes to the wheels, and as soon as the team

has to pull again the brakes are released from the wheels, the brakes thus acting automatically to be applied to and released from the wheels.

At a suitable point upon the reach F is hinged a casting or plate, P, which has ears at its front end projecting downward on each side of the reach, and screws or bolts, passing through said ears into the reach, form the hinge for the same. The rear end of this plate or casting is, by a hook or hooked rod, *d*, connected with a crank, *e*, on a horizontal shaft, J, which is placed in suitable bearings under the wagon-box L, and this shaft J is at one end provided with a lever, K, as shown.

The plate or casting P may be raised by throwing the lever K backward, which thereby gives the reach F liberty to move backward and forward, as above described; but by throwing the lever K forward the plate or casting P drops down and forms a stop against the front ends of the hounds D D, and thus makes the reach rigid, so that the wagon can be backed without applying the brakes.

The wagon-box L, at its front end, rests upon a roller, R, mounted on top of the front bolster C', allowing the box to slide backward and forward without unnecessary friction.

Having thus fully described my invention, what I claim as new, and desire to secure by Letters Patent, is—

1. The plate or casting P, with rod *d* connecting with crank-shaft J, in combination with the reach F and hounds D D, substantially as and for the purposes herein set forth.

2. In a wagon, the brake-lever G, permanently attached to the sliding reach, in combination with the plate or casting P, rod *d*, crank-shaft J, and hounds D D, constructed and arranged substantially as and for the purpose set forth.

In testimony that I claim the foregoing as my own I have hereto affixed my signature in presence of two witnesses.

GOTTLIEB KEMMEL.

Witnesses:

MELVILLE MCGEE,
JOHN W. WARNER.