

T. L. STURTEVANT.
Disintegrating-Mills.

No. 205,440.

Patented June 25, 1878.

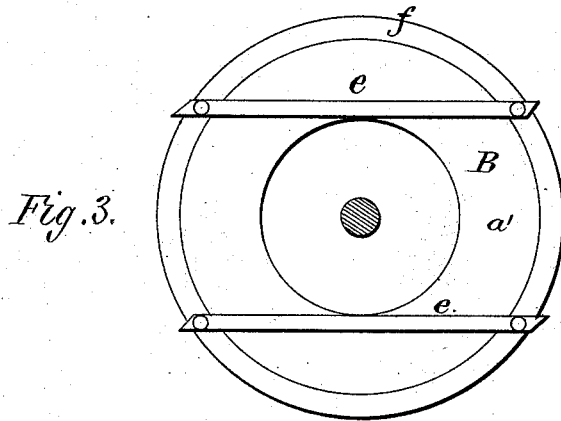
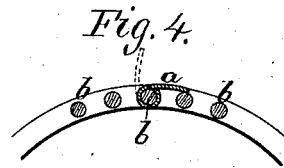
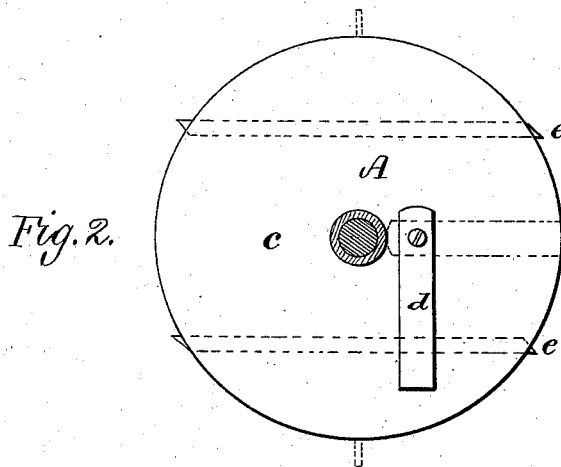
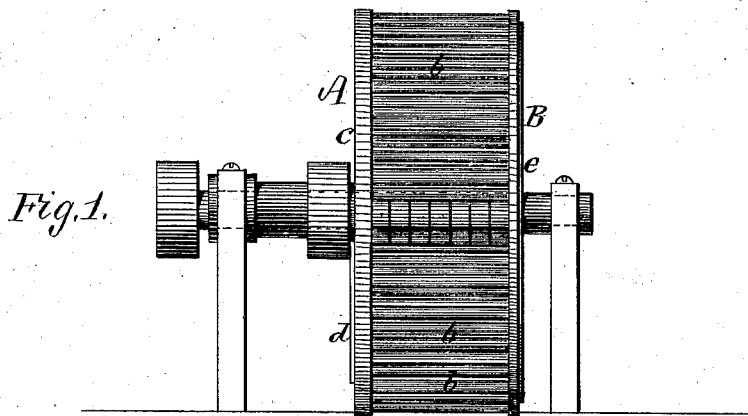

Witnesses.
Wm. Farrell Andrews Jr.
Louis A. Curtis

Inventor.
T. L. Sturtevant.
J. Curtis Atty.

UNITED STATES PATENT OFFICE.

THOMAS L. STURTEVANT, OF SOUTH FRAMINGHAM, ASSIGNOR TO WILLIAM H. BOWKER & CO., OF BOSTON, MASSACHUSETTS.

IMPROVEMENT IN DISINTEGRATING-MILLS.

Specification forming part of Letters Patent No. 205,440, dated June 25, 1878; application filed May 16, 1878.

To all whom it may concern:

Be it known that I, THOMAS L. STURTEVANT, of South Framingham, in the county of Middlesex and State of Massachusetts, have invented certain new and useful Improvements in Disintegrating or Pulverizing Engines, of which the following is a specification:

These improvements relate to a class of mills or engines for reducing or pulverizing, by percussive force, bones, phosphates, or various mineral or animal substances, in which several cylindrical cages are formed of series of bars secured concentrically to hubs or rings, and revolving one within the other in opposite directions, the substances to be reduced being introduced into the inner cage or receptacle, and by the rapid revolution and consequent centrifugal force of the cages are thrown outward against and between the several series of bars, and are granulated or pulverized by the percussive force, and not by grinding or abrasive action.

Engines of this character are very powerful and rapid in action; but serious trouble is experienced with them, for the reason that when reducing wet substances or pastes the mass adheres to the inner surfaces or walls of the outer casing or curb which surrounds such cages, and accumulates until the engine is with difficulty operated.

The purpose of my invention is to provide appliances for these engines which shall effectually prevent this accumulation of material upon the walls of the casing, and to this end I proceed as hereinafter explained.

The drawings accompanying this specification represent, in Figure 1, an edge view, and in Figs. 2 and 3 side elevations, of an engine embodying my improvements, the outer casing or curb being omitted in order to show more clearly those parts of the engine in which my invention is comprised; and Fig. 4 is a section of one of the hinged vanes.

In these drawings, A and B represent two barred cylinders or cages, each of which is composed of end rings and a series of horizontal parallel rods, which unite such rings, the shaft of one cage or series of cages extending through the shaft of the other, and the arrangement of various series of bars being such that they

extend one within the other, and are driven rapidly in opposite directions, in order that material introduced into the inner cage shall, owing to the centrifugal force generated by the rapid revolution, be thrown outward between the two sets of bars and beaten about among the entire series, and finally escape from the outermost set of bars in a granulated or pulverized condition.

In carrying out my improvements, I first add to the circumference of the outer cage A one or more series of vanes, *a a*, &c., and hinge these vanes at one end loosely to some one of the rods or bars *b* of such outer cage.

The centrifugal force generated by the revolution of the cage A throws the vanes outward, so that they radiate from the axis of the cage, and nearly wipe against the interior of the case or hood which surrounds the cage.

Should the material being reduced adhere or tend to adhere to the inner circumference of the casing, the ends of the vanes instantly remove it, and continue to act to keep this portion of the casing free from accumulation.

To the solid head or disk *c* of the outer or large cage A, I pivot near one end a bar or plate, *d*, this bar and its pivot being so disposed with respect to the periphery of the hub, and the shaft which supports such hub, as, when thrown outward radially from the center of such hub by centrifugal force, to extend from such shaft to or somewhat beyond said periphery, and act as a scraper to the adjacent inner end wall of the casing, and prevent deposits of wet materials upon this portion of the casing.

To the opposite end of the case A, I secure two bars, *e e*, by bolting their extremities to the ring *f* of such cage, the bars protruding somewhat beyond the periphery of said ring, and serving, like the plate *d*, to scrape from the contiguous end wall of the casing any material which may tend to cling to such wall. These bars *e e* also serve to scrape and clean the adjacent end *a'* of the inner cage.

By the employment of the vanes *a a*, &c., and the bars *d* and *e e*, I am enabled to maintain the interior of the case in a clean condition, and entirely do away with clogging and obstruction of the rotary cages, thereby obvi-

ating a serious evil in engines of this character.

I claim—

1. The vanes *a a*, pivoted to the circumference of the outer or larger cage A, and operating in manner as explained, to prevent accumulations upon the inner circumference of the case or hood which surrounds the said cage, substantially as and for purposes stated.

2. The swinging bar or plate *d*, applied to the exterior of the cage A, and operating to

scrape the end walls of the case, substantially as and for purposes stated.

3. In combination with the outer and inner cages, the bars *e e*, fixed to and revolving with the outer cage, and operating to scrape not only the adjacent wall of the case, but also the end of the inner cage.

THOMAS L. STURTEVANT.

Witnesses:

F. CURTIS,

LOUIS A. CURTIS.