

C. L. TRAVIS & C. R. CHUTE.  
Grain-Binder.

No. 205,442.

Patented June 25, 1878.

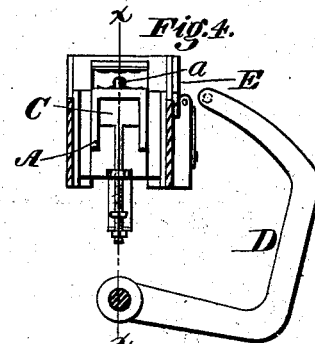
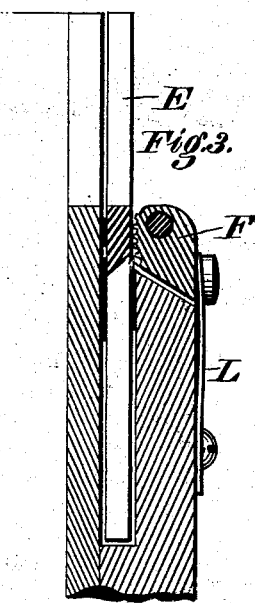
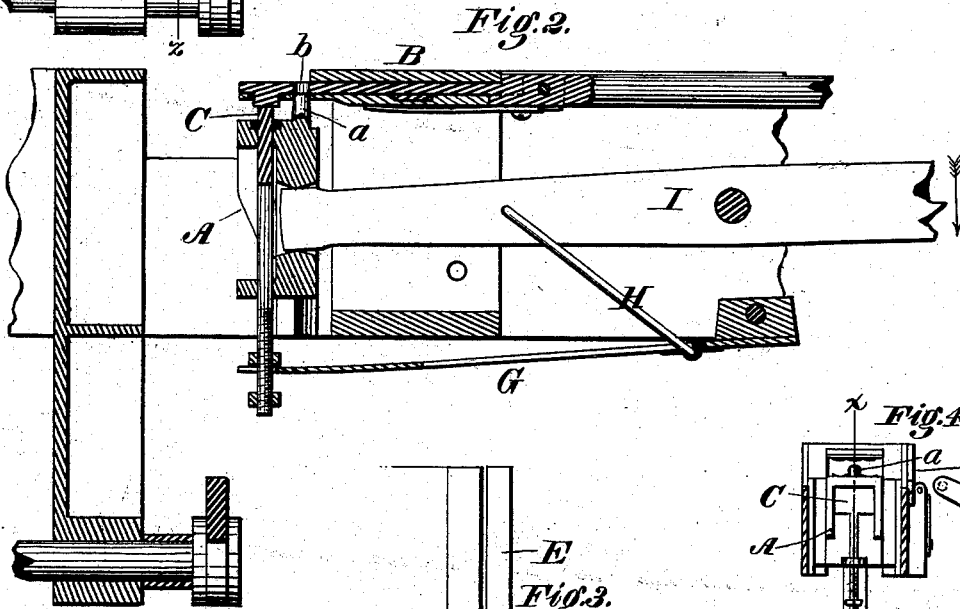
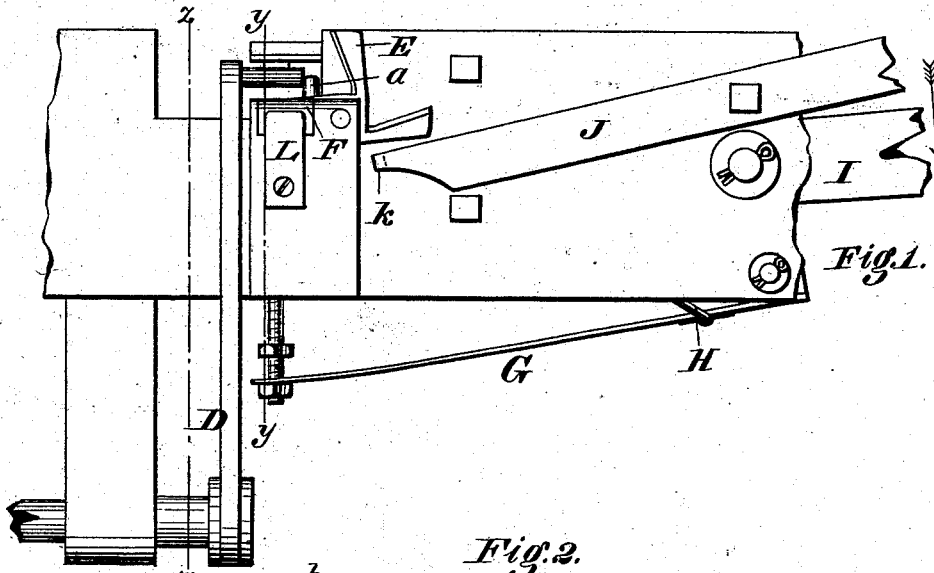

Witnesses:

Donn S. Twitchell.  
S. M. Madden

Inventor:

C. L. Travis  
C. R. Chute  
By his attys.  
Dodgson

# UNITED STATES PATENT OFFICE.

CHARLES L. TRAVIS AND CHARLES R. CHUTE, OF MINNEAPOLIS, MINN.

## IMPROVEMENT IN GRAIN-BINDERS.

Specification forming part of Letters Patent No. **205,442**, dated June 25, 1878; application filed March 27, 1878.

*To all whom it may concern:*

Be it known that we, CHARLES L. TRAVIS and CHARLES R. CHUTE, of Minneapolis, in the county of Hennepin and State of Minnesota, have invented certain Improvements in Grain-Binding Machines, of which the following is a specification:

This invention relates to improvements in the machine for binding grain with paper and similar bands recently patented to Olmsted, Travis, and Chute.

The invention consists in means for insuring an accurate adjustment of the two band-fastening dies with relation to each other; in operating with a positive motion the catch or dog which serves to hold the ends of the applied band prior to its being punched; in an improved arrangement of the carrier-arm, by which the first end of the band is passed between the fastening-dies.

In the drawings, Figure 1 represents a side elevation of that portion of the binding mechanism to which our improvements relate; Fig. 2, a vertical central section through the same on the line  $x x$  of Fig. 4; Fig. 3, a vertical cross-section on the line  $y y$  of Fig. 1; Fig. 4, a cross-section on the line  $z z$  of Fig. 1.

In its general construction and mode of operation the machine represented is essentially the same as that of Olmsted, Travis, and Chute, above referred to, for a detailed description of which reference is made to their patent.

The mechanism represented consists of four essential parts: a vertically-moving die, A; a horizontally-moving die, B, arranged to advance over the former; the vertically-moving dog or catch C, arranged to rise in advance of the die A, and hold the ends of the applied bands against the die B prior to their being punched; the swinging arm or carrier D, by which the first end of the band is brought into position to be embraced between the dies, and a rotary band-cutter, E, which also acts, in conjunction with the pivoted cam F, to retain the end of the band.

The dies A and B are constructed and arranged to operate in the same manner as in the patented machine above referred to. In that machine, however, difficulty has been sometimes experienced in bringing the two

dies exactly in line with each other, so that the one would accurately enter the other.

The first feature of our invention is designed to overcome this difficulty, and to this end consists in mounting upon one of the dies a taper or inclined pin or guide, arranged to enter a corresponding hole or cavity in the other die, so that, as the one die approaches the other, the two are brought exactly in line before commencing their action upon the band. The form and location of the pin or guide with relation to the dies may be modified as experience shall dictate; but good results have been secured by simply providing the vertically-moving die A, on its upper end, with a rigid tapering pin,  $a$ , and providing the upper die B with a corresponding hole,  $b$ . The upper die being first advanced to its operative position; the rise of the die A causes its pin to enter the hole  $b$ , the effect of which is to bring the two dies exactly in line before their action upon the band commences. The die A is, of course, arranged to descend and withdraw the guide-pin from the upper die before the latter moves backward. The dog or catch C is arranged to slide upward through or beside the die A, as in the original machine referred to; but instead of being dependent for its operation upon a spring, we connect it at its lower end to the free end of the pivoted arm G, which latter is connected by a link, H, to the lever I, which latter engages with and serves to operate the vertically-moving die A.

The link H is connected to the arm G at a point near its fulcrum, and connected to the lever I at a greater distance from its fulcrum, the consequence of which is that the arm G moves upward with greater rapidity than the lever I. When, therefore, the lever I is operated to lift the die A the dog or catch C is moved upward in advance of the die, and caused to hold the ends of the band against the die B, while the die A rises and acts upon them.

In order that the lever I may continue its movement with the die A after the dog C has come to a stop, the arm G is made elastic, but of such strength as to move the dog or catch upward with absolute certainty and hold it with great firmness upon the band. Other mechanism may be substituted for imparting

a positive motion to the catch or dog; but the arrangement shown is considered the best for practical use that can be adopted.

The upper end of the arm D operates in the same manner as in the original machine to pass the band over the vertical die; but the body of the arm, instead of being made straight and passed upward directly through the frame from the rock-shaft at its lower end, as in the original machine, is now curved outward and upward behind the outside of the frame, and thence inward over the top of the same, as clearly represented in Figs. 1 and 4. This curvature of the arm gives an open clear space within the frame, and avoids the necessity which existed in the original machine of cutting an opening through the rear side of the frame to allow the arm to swing inward and outward.

The rotary cutter E is constructed in the same, or substantially the same, manner as in the original machine; but, instead of being rotated by a vertical pawl, it now receives motion from the pivoted lever J, provided at one end with a beveled lip, K, and made sufficiently elastic to swing sidewise over the arms of the cutter. On depressing the forward end of the lever J its lip K rides over one arm of the cutter and engages thereunder, as shown in Fig. 1, and then, as the end of the lever rises, its lip, acting upon the said arm, imparts to the cutter one-fourth of a revolution, and so on repeatedly, the different arms of the cutter being acted upon successively, and the cutter rotated continually in one direction and one-fourth of a revolution at each rise of the lever.

The lever may receive its vibratory motion from any suitable part of the machine; but it is preferred to connect its outer end to a sliding rod, acted upon by the cam-wheel.

The eccentric or cam F, by which the band is held, is located, as in the original machine, directly behind the cutter, and pressed toward the same by a spring, L, the front face of the cam being provided with teeth or serrations, whereby it is enabled the better to hold the band.

Having thus described our invention, what we claim is—

1. In a grain-binding machine, the combination, with the band-carrying mechanism, of two dies movable in relation to each other, and a guide attached to one of said dies and arranged to act upon the other, for the purpose of bringing them exactly in line with each other.

2. In combination with the dies A B, the dog or clamp C, operated by positive-acting mechanism, and arranged to rise in advance of the die A, substantially as shown.

3. The combination of the die A, dog C, lever I, arm G, and link H.

4. In a grain-binding machine, the combination of the dies A B and the carrier-arm D, curved upward and around the outside of the band-fastening mechanism, substantially as shown.

CHARLES L. TRAVIS.  
CHARLES R. CHUTE.

Witnesses:

FRANK J. MEAD,  
JOSEPH G. TURNER.