

A. GERARD.
 Electric Auto-Pneumatic Water Indicator.
 No. 205,539. Patented July 2, 1878.

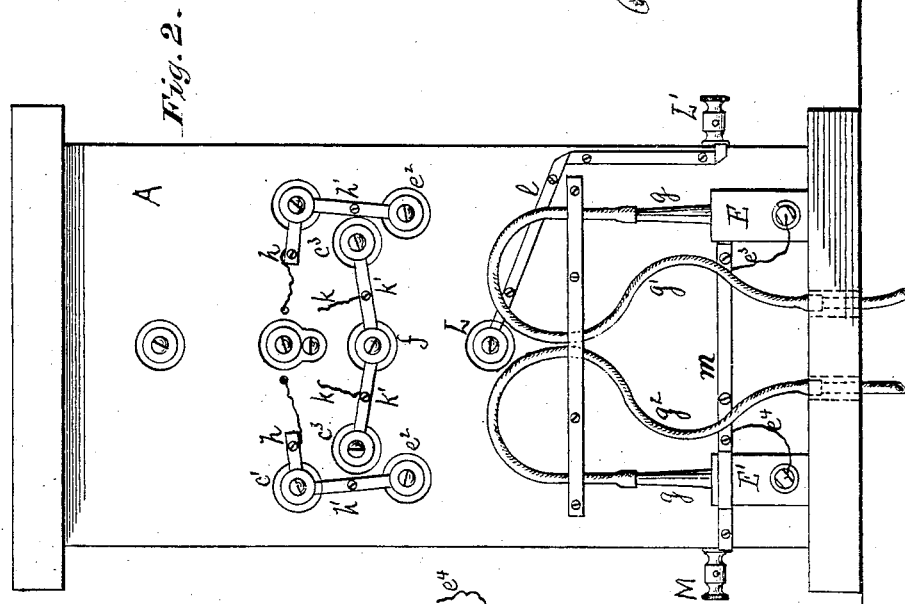
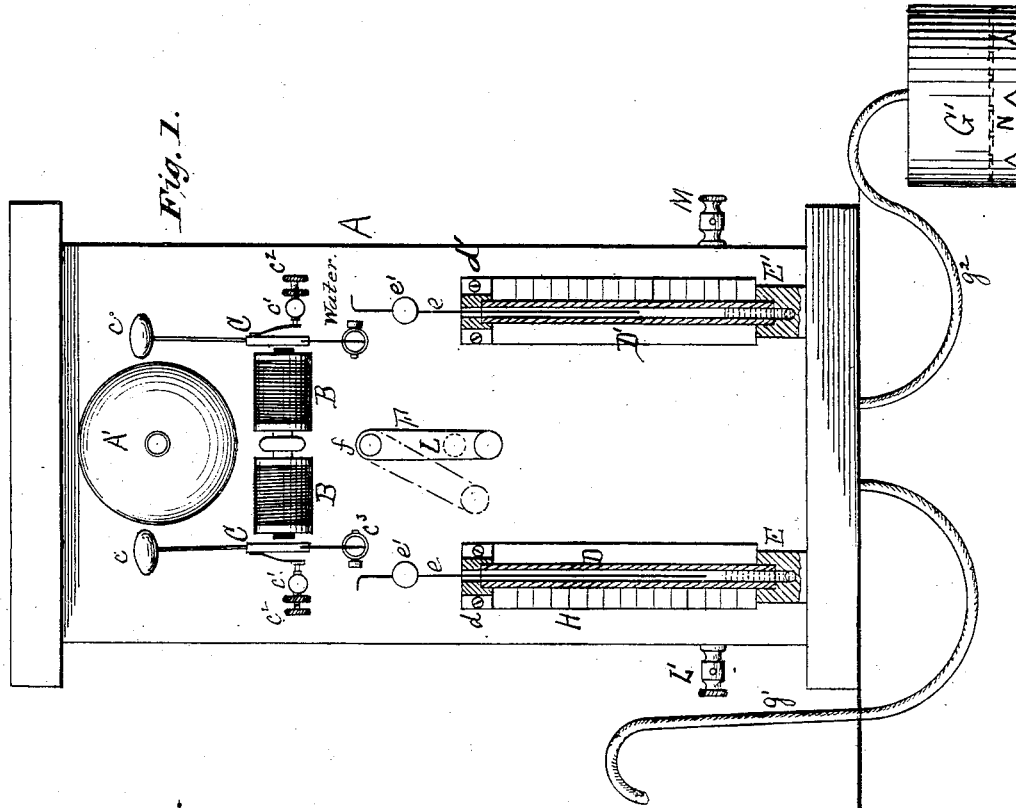

Witnesses:

J. C. Brecht
J. J. Lampson

Fig. 3.

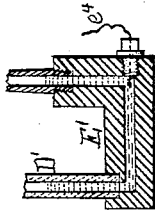

Inventor:

Gerard

UNITED STATES PATENT OFFICE.

ARISTIDE GERARD, OF NEW ORLEANS, LOUISIANA.

IMPROVEMENT IN ELECTRIC AUTO-PNEUMATIC WATER-INDICATORS.

Specification forming part of Letters Patent No. 205,539, dated July 2, 1878; application filed January 28, 1878.

To all whom it may concern:

Be it known that I, ARISTIDE GERARD, of New Orleans, in the parish of Orleans and State of Louisiana, have invented certain Improvements in Auto-Pneumatic Water-Indicators, of which the following is a full, clear, and exact description, reference being had to the accompanying drawings and the letters of reference marked thereon, making part of this specification, in which—

Figure 1 is a front view, parts being removed. Fig. 2 is a rear view, and Fig. 3 is a vertical sectional view of the tube containing the mercury.

The nature of my invention consists in a simple and effective arrangement for the almost instantaneous detection of the presence of water in the holds of vessels, notice of the danger being given and recorded by the indicator at any desired place from the point protected by the apparatus in the hold, or any compartment thereof.

The construction and operation of my invention are as follows:

A is the frame, to which the different features of the mechanism are secured. In the upper section of this frame is secured the bell A', and immediately below the bell are the magnets B B. C C are the armatures, to which are secured the clappers *c c*. D D' are tubes located on each side of the frame and in the lower section thereof. The upper ends of these tubes are secured to the frame by means of the brackets *d d'*, while the lower ends are connected with the tubes E E', which contain the mercury. *e e* are needles, which pass down into the tubes D D' respectively, being adjustable by means of the screws *e' e'*, or any other suitable means. From the fact that these needles are adjustable, it allows their points to be set so near to the mercury-column that the slightest pressure of water upon the air in the cylinder G' will complete the connection and cause the alarm to sound. These needles *e e* pass through the binding-posts *e² e²*.

F is the switch, which is pivoted at *f*. E E' are the tubes which contain the mercury, and are bent in the form shown in Fig. 3. *e¹ e¹* are binding-posts, which are connected with the armatures C C by means of screws *e² e²*.

e³ e³ are the binding-posts of the armatures C C.

On the rear side of the frame A, as shown in Fig. 2, to each of the tubes E E' is secured a tube, *g*. From each of the tubes *g g* extend flexible air-tight tubes *g¹ g²*, which are connected with cylinders G', only one of which is shown. These cylinders G' are open at the bottom for the free passage of water therein, and may be located in different compartments of the hold of the vessel. A short distance above their bottom they are provided with a perforated plate, N, or other suitable device, to prevent débris or other matter from collecting in the cylinders and preventing their successful operation. *h h* are the connections between the binding-posts *e¹ e¹* and the magnets B B. *h' h'* are the connections between the binding-posts *e² e²* of the adjustable needles *e e* and the binding-posts *e¹ e¹*. *k k* are the connections between the binding-posts *e³ e³* of the armatures C C and the magnets B B, and *k' k'* are the connections between the armatures C C and the switch F.

L is a button, which is connected with the binding-post L' of the battery by the band *l*. *m* is a band, which is connected with the binding-post M of the battery.

The mercury in the tube E is connected with the band *m* by means of the wire *e³*, and the mercury in the tube E' is connected with the band *m* by means of the wire *e⁴*.

H H are graduated scales, located respectively in the rear of the tubes D D', and indicate the rise and fall of the water after the alarm is given and the attention of the person in charge is called to the fact that there is water in the hold of the vessel.

The operation is as follows: For the detection of water in any one of the compartments of the hold of the vessel, one of the cylinders G', open at the bottom and connected from its interior with one of the indicators D D' through one of the extensible flexible air-tight tubes *g¹ g²*, is placed in that compartment. As soon as any ingress of water takes place surrounding the cylinder G' the atmospheric air thus confined is submitted to the vertical pressure and density of that water, no matter to what degree that may be. The air so compressed transmits that pressure to the indi-

cator with which the cylinder is connected through its extensible flexible air-tight tube. That pressure is received upon the surface of the mercury contained in one of the branch tubes E', depressing it in that branch in proportion to the amount of hydrostatic pressure in the hold, and raising it in the opposite branch of the bended tube E' to a height corresponding to the hydrostatic pressure on the air in the cylinder in the bottom of the hold.

The use of the mercury has two objects, one to record and indicate the progress of the water, the other to close the electric circuit with the battery. The circuit is closed by means of the adjustable needle E.

The needle can be set at any height to give the alarm, and, being adjustable, can be set so close to the mercury that the presence of almost the slightest quantity of water in the

cylinder G' will cause the mercury to rise and give the alarm. The presence of water being detected, the ringing of the bell A' can be stopped at will by disconnecting the switch F from its button L.

What I claim as new, and desire to secure by Letters Patent of the United States, is—

In an auto-pneumatic water-indicator, the cylinder G', air-tight tube g^2 , mercury-tube E', wire e^4 , tube D', adjustable needle e , and screw e^1 , in combination with an electric alarm, substantially as described.

In testimony that I claim the foregoing I have hereunto set my hand this 28th day of January, 1878.

A. GERARD.

Witnesses:

J. S. LANPHIER,

J. W. HAMILTON JOHNSON.