

O. S. DEMING.
Corn-Planter.

No. 205,618.

Patented July 2, 1878.

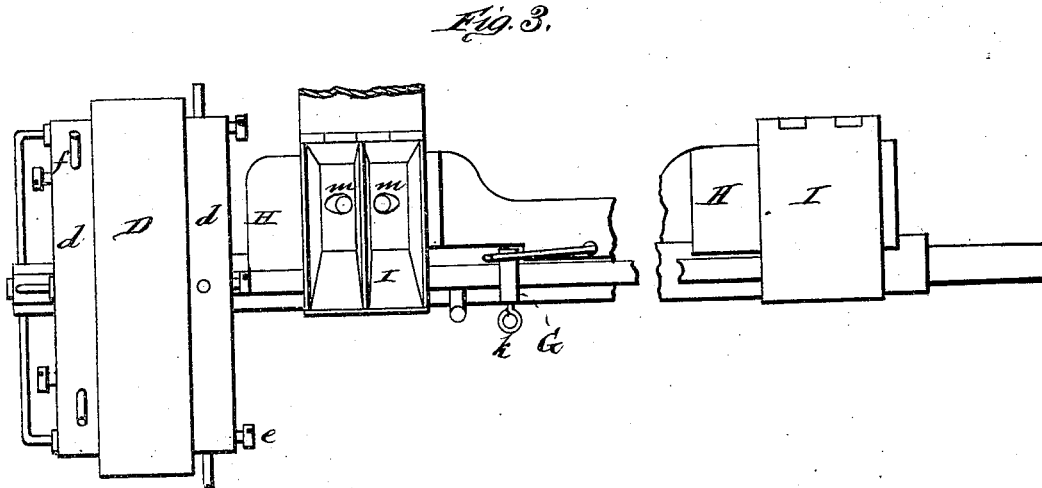
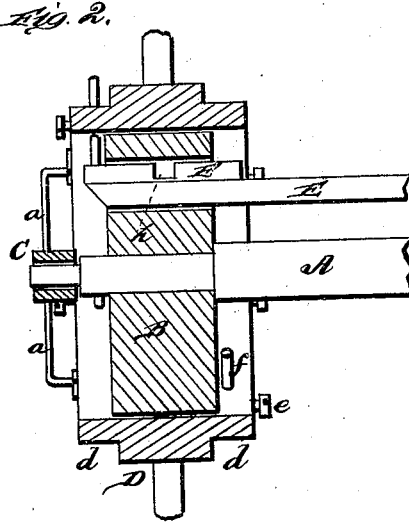
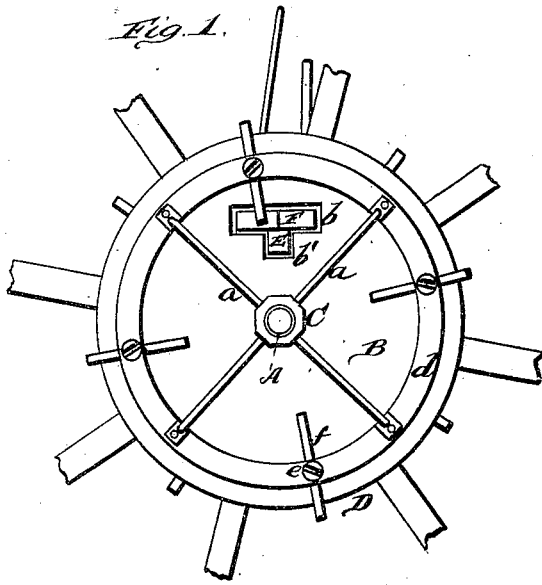

WITNESSES

Robert Sweett
James J. Sheehy

INVENTOR.

Oscar S. Deming
Gilmore Smith

ATTORNEYS.

O. S. DEMING.
Corn-Planter.

No. 205,618.

Patented July 2, 1878.

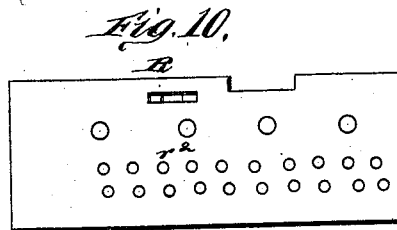
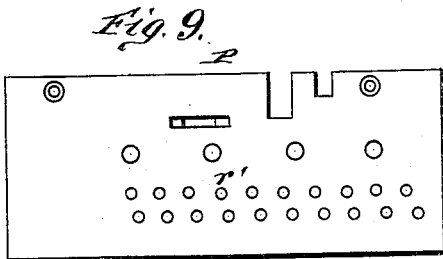
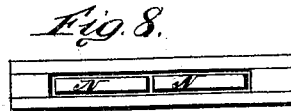
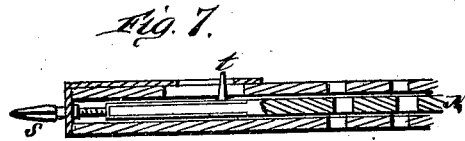
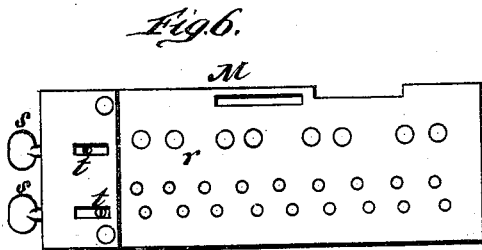
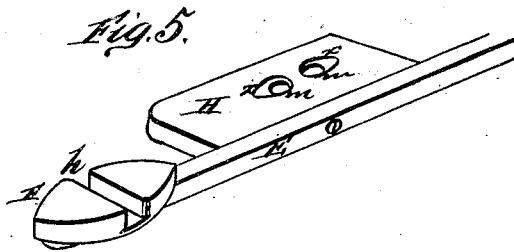
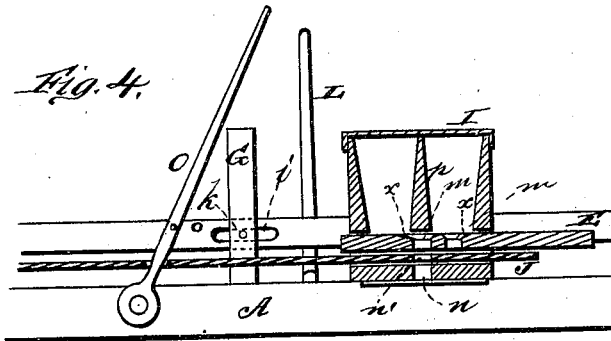

WITNESSES
Robert Smith
James J. Sherry

INVENTOR.
Oscar S. Deming
Gilmore Smith & Co.
 ATTORNEYS.

UNITED STATES PATENT OFFICE.

OSMER S. DEMING, OF MOUNT OLIVET, KENTUCKY.

IMPROVEMENT IN CORN-PLANTERS.

Specification forming part of Letters Patent No. **205,618**, dated July 2, 1878; application filed April 6, 1878.

To all whom it may concern:

Be it known that I, OSMER S. DEMING, of Mount Olivet, in the county of Robertson and State of Kentucky, have invented a new and valuable Improvement in Combined Sulky Corn-Planters; and I do hereby declare that the following is a full, clear, and exact description of the construction and operation of the same, reference being had to the annexed drawings, making a part of this specification, and to the letters and figures of reference marked thereon.

Figure 1 of the drawings is a representation of a side view of a portion of my combined planter and drill. Fig. 2 is a sectional view. Fig. 3 is a plan view. Fig. 4 is a sectional view. Fig. 5 is a perspective detail. Fig. 6 is a detail. Fig. 7 is a sectional detail; and Figs. 8, 9, and 10 are detail views thereof.

The nature of my invention consists in the construction and arrangement of a combined sulky corn-planter and drill, corn-plow, broadcast grain and seed sower and drill, as will be hereinafter more fully set forth, and pointed out in the claims.

The annexed drawings, to which reference is made, fully illustrate my invention.

In the construction of my machine, a pair of shafts or a tongue is to be so attached to an iron axle, A, as to allow the axle to turn in the fastenings. One end of the axle enters and is secured to the wheel in the ordinary way. The other end of the axle passes through a stationary center wheel, B, firmly attached to the axle, the end resting in a small hub, C, which revolves around the end of the axle, and is firmly connected by braces *a a* with the hub D of the driving-wheel, giving a steady movement to the wheel. The axle A and center wheel B remain stationary.

Through and near the top of the center-wheel B is an oblong mortise, *b*, communicating with a slot, *b'*, under the center of said mortise, and the center of said slot is directly over the center of the axle. Through this mortise and slot move the shuttle-shaped cam F and horizontal feed-bar E.

The opening through the driving-wheel hub D is sufficiently large to allow it to rotate around the stationary center wheel B.

On each side of the hub D is a projecting

flange, *d*, through which pass a series of pins, *f f*, held in their places by set-screws *e e*. These pins are intended to drive the cam F, and are arranged radially at equal distances apart, in such a manner that those on one side will be directly opposite a point midway between those on the other side.

The ends of the cam or shuttle F are made oval or V-shaped, and when the driving-wheel revolves the pins or shuttle-drivers *f* on opposite sides come alternately in contact with the ends of the shuttle, thus forcing the shuttle and feed-bar, to which it is firmly attached at one end, alternately from right to left, and vice versa.

Across the shuttle F, in the center, is a slot, *h*, through which the drivers *f* on the inner flange of the hub D move when the machine is thrown out of gear, thus preventing the movement of the machinery.

The oval ends of the shuttle allow the machine to work equally as well in backing as in going forward.

The feed-bar E extends from the slot *b'* in the center wheel B parallel with the axle, and passes through a rest, G, nearly to the other wheel. At the point in the feed-bar passing through said rest G is a slot, *i*, through which passes a gage-pin, *k*, regulating the stroke of the shuttle.

Attached to the feed-bar E are two or more feed-slides, H H, in such a way that they can be easily removed, which feed-slides pass horizontally through the hoppers I I, and are each provided with two openings, *m m*, for the reception of the grain.

The hoppers are attached to the axle A, and each one has an opening, *n*, in the bottom, through which the corn or grain passes to the ground through a hollow leg or conductor attached to the axle, and provided with a shoe or plow-point to make a place for and cover the grain.

Passing horizontally through the bottom of the hoppers, and immediately beneath the feed-slides H, is a cut-off, J, with openings *n'* corresponding to the delivery-openings *n* in the hoppers, which cut-off is moved and regulated by a lever, O, held fast at the top by a ratchet near the driver's seat. When the lever O is moved to the left the delivery-open-

ings *n* in the hoppers are closed, and no grain can escape, though the feed-slides may be in motion.

The hoppers are each provided with a partition, *p*, which may have, if desired, a brush in the bottom over the delivery-openings *n*.

The openings *m m* in the feed-slides *H* are to be provided with adjustable slides to regulate the quantity of grain to be delivered each time in any of the known and usual ways.

The lateral movement of the feed-bar *E* causes the feed-slides *H* to move from right to left, and vice versa, alternately exposing one of the openings *m* in each slide for the reception of the grain, while the other opening *m* is under the partition *p* and over the delivery-opening in the bottom of the hopper, thus allowing the escape of the grain.

The machine may be thrown out of gear by removing the gage-pin *k* and placing the same, through a hole in the feed-bar, into the lever *O*, and turning said lever to the left, which will allow the drivers *f* on the inner flange *d* to pass through the slot *h* in the shuttle *F*. A movement of the lever *O* to the right, and replacing the pin *k* in the rest *G*, throws the machine in gear again.

The hoppers and feed-slides may be moved in or out on the axle and feed-bar to vary the distance between the rows, and by raising or lowering corresponding drivers *f* on the right and left of the hub *D*, so that a greater or lesser number will come in contact with the shuttle—which can be done by loosening the set-screws *e*—the distances between the hills may be varied to suit the operator.

The machine may be changed from a planter to a drill by simply lessening the size of the delivery-openings *m* in the feed-slides *H* and causing a greater number of shuttle-drivers *f* to come in contact with the shuttle *F*, and vice versa.

L is a lever attached to the axle. By throwing this lever forward the axle turns, throwing the plows or hoes backward out of the ground, allowing them to pass over small obstacles, while the seat is to turn on the axle and remain in an upright position. The lever *L* is also to be secured by a ratchet near the driver's seat.

In order to use the machine as a sulky corn-plow, it is only necessary to remove a part of the planting attachments—the hoppers, cut-off, shuttle, and feed-bar—and attach to the axle two or more double-shovel plows, the lever *L* being operated for the same purpose as in the planter.

The axle may be made crooked or arched in the middle, in order to pass over higher corn.

To use the machine as a grain-drill and broadcast-sower, the tongue or shafts may be used. The corn planting and plowing attachments are to be removed, retaining the levers, shuttle, and feed-bar. To the feed-bar is then attached the feed-slide *M*, which is provided with one or more rows of delivery-openings, *r*,

of different size, for the passage of the grain and grass-seed, so arranged that one or more of said openings will be continually over the delivery-openings in the bottom of the hopper.

The feed-slide *M* is also provided with adjustable slides *N*, controlled by means of suitable thumb-screws *s*, by means of which the quantity of grain or seed desired to be sown or drilled per acre may be varied to suit the operator, and is regulated by indicators *t* on the upper surface and near the end of the feed-slide.

Attached to the axle *A* should then be the feed-box or hopper, in the bottom *P* of which are delivery-openings *r*¹ for the escape of the grain and seed. Immediately over the bottom *P*, and containing corresponding openings *r*², is the cut-off *R*, controlled by the lever *O*.

The hopper is to contain a partition between the grain and grass-seed openings and other suitable divisions. The alternate lateral movement of the feed-bar will cause the openings in the feed-slide to pass over the delivery-openings in the cut-off and hopper, thus forcing the grain and seed out.

If it is desired to sow the seed broadcast, no hoes or other drill attachments are necessary; but a harrow may be attached to the axle to follow along and cover the grain.

If it is desired to drill in the grain, the hoes and other suitable drill attachments of any of the known and usual grain-drills may be added. The levers *O* and *L* are to be operated in a similar way and for a like purpose as in the planter.

The operation of my device is not necessarily confined to a sulky corn-planter and drill, as above set forth, but may be attached to a small shovel-plow for the purpose of planting or drilling one row of corn at a time, when the nature of the ground will not allow the sulky planter and drill to be used, the plow then having similar attachments and to be operated in a similar way as in the sulky-planter; and for the purpose of a grain-drill, to be used between corn-rows, one or more side beams may be added on each side of the beam containing the driving-wheel, so attached at the front end as to allow the machine to be widened or drawn together at pleasure, all controlled by levers similar to the planter, and to have suitable hoe or plow attachments to make places for and to cover the grain.

Hoppers, feed-slides, and cut-offs similar to those in the sulky grain-drill are to be placed on each side of the driving-wheel. The shuttle will be placed in the middle of the feed-bar, with similar arrangements for regulating the quantity of seed to be drilled, and for throwing in and out of gear, and for cut-off, as in the sulky-drill.

The openings *m* in the feed-slides *H*, it will be seen, have each a bevel, *x*, in the side farthest from the partition in the seed-box, which is a great advantage, as it gives an easier passage of the slides under the partition, causing less

friction, and when no brush is used it entirely prevents the cutting of the grain in passing under the partitions.

The driving-wheel of the planter will be provided with a rubber or suitable lever to regulate and adjust the wheel at the beginning points in the field, so that uniformity of rows may be secured.

The shuttle may be made round and attached to the feed-bar by a bolt in such a way that it will turn when it comes in contact with the drivers.

The driving-wheel may also be made to turn on the axle like an ordinary carriage-wheel. On the inner side of the hub, or surrounding the hub and attached to the inner side of the spokes, will be fastened a flange in such a way that it can be removed at pleasure, and this flange to contain the shuttle-drivers. The feed-bar will be supported on the axle, and the shuttle made diamond-shaped.

Having thus fully described my invention, what I claim as new, and desire to secure by Letters Patent, is—

1. The driving-wheel provided with a flanged hub, *D d*, and adjustable shuttle-drivers *f* and shuttle *F*, combined with adjustable feed-slides and a cut-off mechanism, as herein specified.

2. The oval or diamond shaped shuttle *F*, operated by the adjustable drivers *f* in the flange *d*, combined with a feed-bar, and operating two or more adjustable feed-slides in movable hoppers, as herein specified.

3. The oval or diamond shaped shuttle *F*, with slot *h*, adapted to throw the feed mechanism out of action, and allow the drivers *f* to pass idly through the slot, as specified.

4. The combination of the shuttle *F h* with the slotted feed-bar, rest, and gage-pin, as and for the purpose described.

5. The cut-off *J*, with openings *n'* and lever *O*, arranged and combined to serve relatively to two or more slides, *H m*, and movable hoppers *I n*, as herein specified.

6. The lever *O*, adapted to serve the double function of operating the cut-off and also to throw the shuttle and feed mechanism out of gear by means of gage-pin *k*, as specified.

In testimony that I claim the above I have hereunto subscribed my name in the presence of two witnesses.

OSMER S. DEMING.

Witnesses:

GEO. W. WHITE,
N. T. BUCKNER.