

L. GIBBS.
Plow.

No. 205,631.

Patented July 2, 1878.

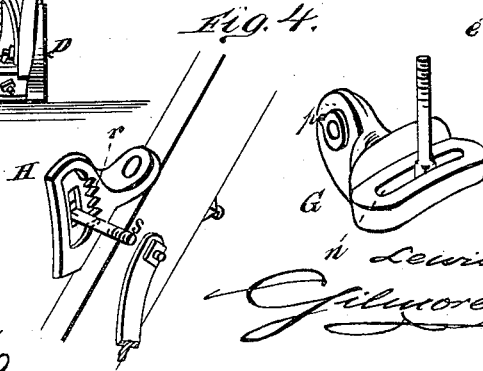
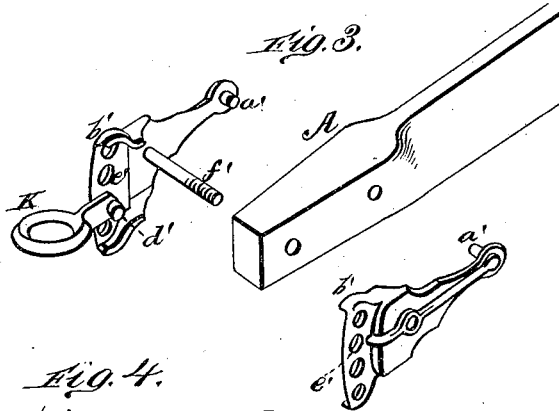
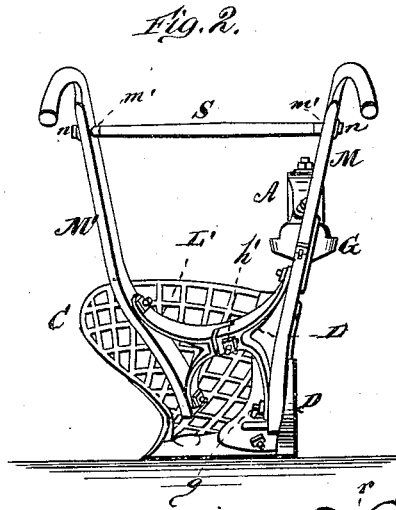
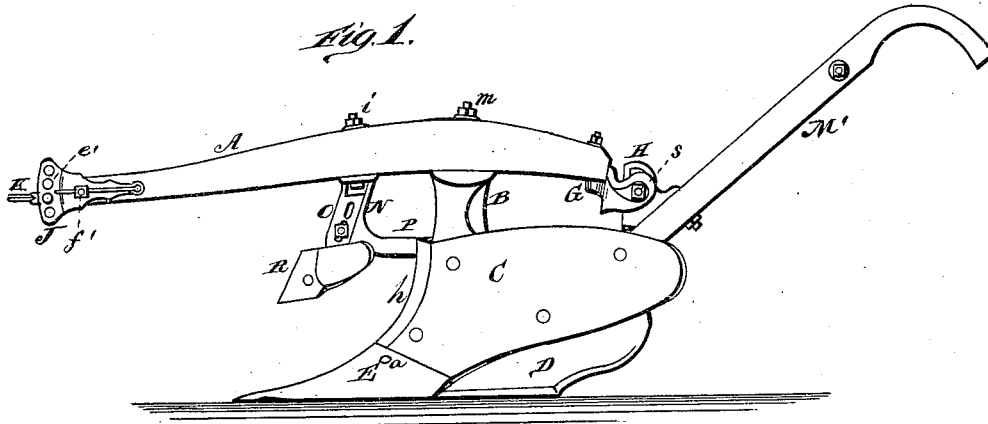

WITNESSES

Robert Everett,
Jas. J. Shreeve,

INVENTOR.

Lewis Gibbs.

Gilmore, Smith & Co.

ATTORNEYS.

L. GIBBS.
Plow.

No. 205,631.

Patented July 2, 1878.

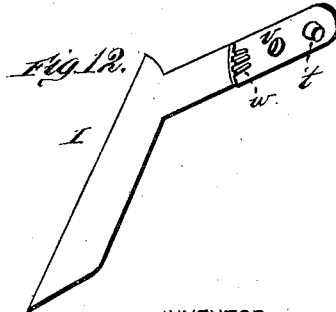
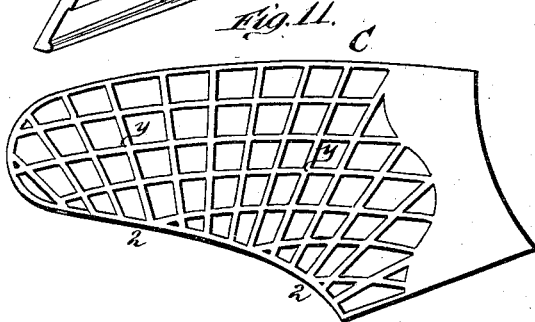
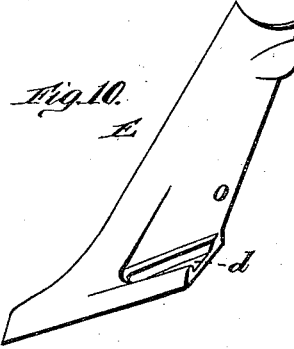
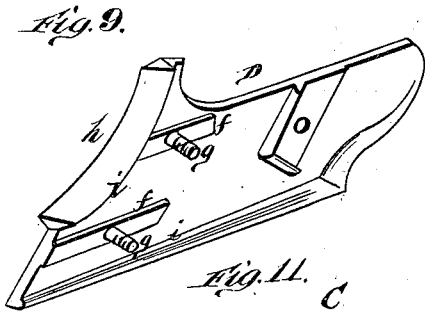
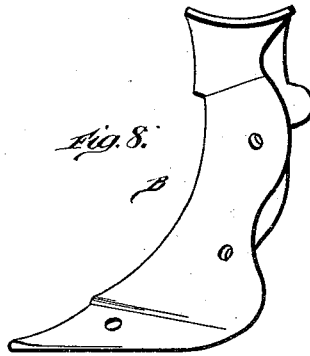
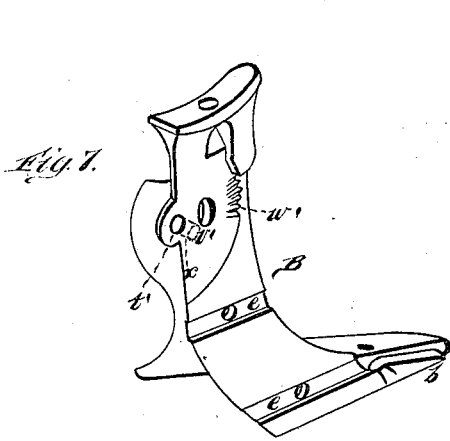
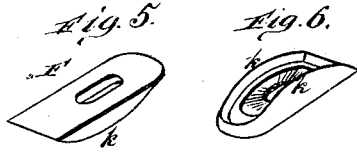

WITNESSES
Robert Everett
Geo. J. Shreeve

INVENTOR,
Lewis Gibbs.
Spilwoore, Smith & Co.
ATTORNEYS.

UNITED STATES PATENT OFFICE.

LEWIS GIBBS, OF CANTON, OHIO, ASSIGNOR TO HIMSELF, JOHN R. BUCHER,
AND WILLIAM A. WIKIDAL, OF SAME PLACE.

IMPROVEMENT IN PLOWS.

Specification forming part of Letters Patent No. **205,631**, dated July 2, 1878; application filed
March 2, 1878.

To all whom it may concern:

Be it known that I, LEWIS GIBBS, of Canton, in the county of Stark and State of Ohio, have invented a new and valuable Improvement in Plows; and I do hereby declare that the following is a full, clear, and exact description of the construction and operation of the same, reference being had to the annexed drawings, making a part of this specification, and to the letters and figures of reference marked thereon.

Figure 1 of the drawings is a representation of a side view of my plow. Fig. 2 is a rear view. Figs. 3, 4, 5, 6, 7, 8, 9, 10, 11, and 12 are perspective details of the same.

The nature of my invention consists in certain improvements in a plow, as will be hereinafter more fully set forth, and pointed out in the claims.

The annexed drawings, to which reference is made, fully illustrate my invention.

A represents the plow-beam; B, the standard; C, the mold-board; D, the land-side bar; and E, the share.

The standard B is provided at its lower forward end with a lug, *b*, upon which fits snugly a depression or socket, *d*, of the land-side portion of the share E, thus securing the share fully against breakage or strain upon the bolt *a*, which connects the standard and share. This form of lock fully overcomes the difficulty of shrinkage often experienced in the hard iron generally used for shares.

The land-side D is provided with parallel projecting bars or ribs *f f*, which fit snugly into grooves or depressions *e e* on the standard, and thereby preventing all strain upon the bolts *g g*, which secure the land-side to the standard.

The front part of the land-side forms a sharp dividing edge or colter, *h*, that extends upward far enough to cut the full depth of the furrow-slice, and projects over far enough on the mold-board side to form a bearing or base for the forward edge of the mold-board, and on a line with the face of the mold-board. Thus the cutting or front edge of the plow is renewed each time the land-side is worn out, or replaced without the additional cost of an extra shin-piece.

The shin-piece of the land-side D forms a shoulder or bearing, *i*, upon the standard B, giving it additional strength, and forms, in connection with the bars *f* and depressions *e*, the base-line or set of the plow, and which is so strong and rigid that no strain or wear can change it.

The top part of the standard B is made concave to fit a movable or sliding cap-piece, F, which is made convex to fit the rounding side of the same circle, and is provided with flanges *k k* to keep it from moving sidewise, but allowing it to move freely in the plane of its circle.

The cap F is provided with a slot, through which passes the bolt *m*, and which slot is made long enough to prevent its coming in contact with the bolt when the cap is moved forward or backward to change the pitch of the beam.

Upon the rear end of the beam A is a casting, G, having a slot, *n*, for the purpose of setting the beam in or out of land, and a lug or point, *p*, which fits or meshes with the teeth *r* on the handle-piece H, said piece being firmly bolted to the handle. Any degree of pitch is obtained by changing the point *p* of the beam-piece G up or down in the teeth or ratchet *r* of the handle-piece H, and is firmly secured together by a bolt, *s*, passing through both pieces, and moving the adjustable cap-piece F of the standard B back or forward to suit the pitch of the beam required.

A knee-cutter, I, has at its upper end a projecting lug, *t*, bolt-hole *v*, and teeth *w*, arranged to correspond with a recess, *t'*, bolt-hole *v'*, and teeth *w'* on the standard B, and is adjustable up and down on the standard, and held firmly in any desired position by a bolt, *x*, passing through the bolt-holes *v v'*.

Chilled-iron mold-boards very often break in cooling in use; and to avoid this expense and trouble they are made of extra thickness, which adds much to the weight and cost of the plow. The mold-board C, over about two-thirds of its inner surface, is recessed or barred to about one-third of its thickness, as shown at *yy*, thus removing a great deal of useless iron and having it of full strength against breaking in cooling. The forward part, where the friction

is the greatest upon the mold-board, is of full thickness to receive the extra wear. The bars *y* are so arranged as to diverge from the points *z z*, which represent the gate or sprue, cut from *z* to *z*. This arrangement of the bars induces the molten iron to flow and diffuse itself more evenly over the entire mold-board, and a much lighter mold-board is obtained, still retaining the full strength.

J represents the clevis, provided with lugs *a'* and flanges *b'*, and a number of holes, *e'*, into which latter fits the cross-bars *d'* of the link K, which, when inserted in the holes *e'* and corresponding holes bored in the beam for the lugs *a'* and bolt *f'*, makes a very strong and light clevis. The cross-bar *d'* of the link is inclined forward, so as to prevent the clevis from spreading.

L L' represent a beam and mold-board handle brace-frame. The upper end of the part L is secured to the handle M by the same bolt that fastens the handle-piece H, and the lower end fastened to the same handle by the same bolt that fastens the land-side. The part L' is fastened to the handle M' by the mold-board bolts, the frame itself forming at its ends washers for the nuts to screw against.

The centers of the two parts extend inward, overlapping each other, and bringing two serrated surfaces in contact. These parts have also elongated holes for the passage of a bolt, *h'*, to secure or lock the frame firmly in position. This device is self-adjusting, adapting itself to the difference of width in plows, and braces firmly in all directions.

N represents a jointer-frame, having a slotted head, O, which allows the bolt *i'* that secures it to the beam to move easily through the slot when the nut on the bolt is loosened as the beam is moved in or out of land. The arm P of said frame extends back, and is secured to the standard B by a bolt through

holes in it. This arm acts as a strong brace to receive all the strain upon the joints, and at the same time keeps the jointer in perfect line with the plow while changing the beam to any set.

R represents the jointer, adjustably secured to the frame N.

The upper round used in fastening the ends of plow-handles together has, generally, its ends inserted in holes bored large enough through the handles to admit them, and is fastened by pins or nails. This destroys the strength of the handle, and frequently causes it to break. The round S, (shown in the drawing,) is at each end provided with a metal ferule, *m'*, and fastened by passing a wood-screw, *n'*, through each handle. The small hole required for the bolt through the handle leaves it of full strength at that point.

What I claim as new, and desire to secure by Letters Patent, is—

1. The combination of the standard B with lug or projection *b* and the share E, with the depression or socket *d*, constructed as described, and for the purpose set forth.
2. The adjustable handle-brace frame L L', made in two pieces, connected together and to the handles, substantially as set forth.
3. In a plow, the combination of a jointed clevis at the rear end of the beam, made in two parts, for attachment to the beam and handle, and a knee-colt attached to the standard by a lug, bolt, and ratchet, both admitting of up and down movement, as herein specified.

In testimony that I claim the above I have hereunto subscribed my name in the presence of two witnesses.

LEWIS GIBBS.

Witnesses:

HIRAM K. GRANT,
F. B. WERNER.