

W. S. HULL.
Flying-Toy.

No. 205,647.

Patented July 2, 1878.

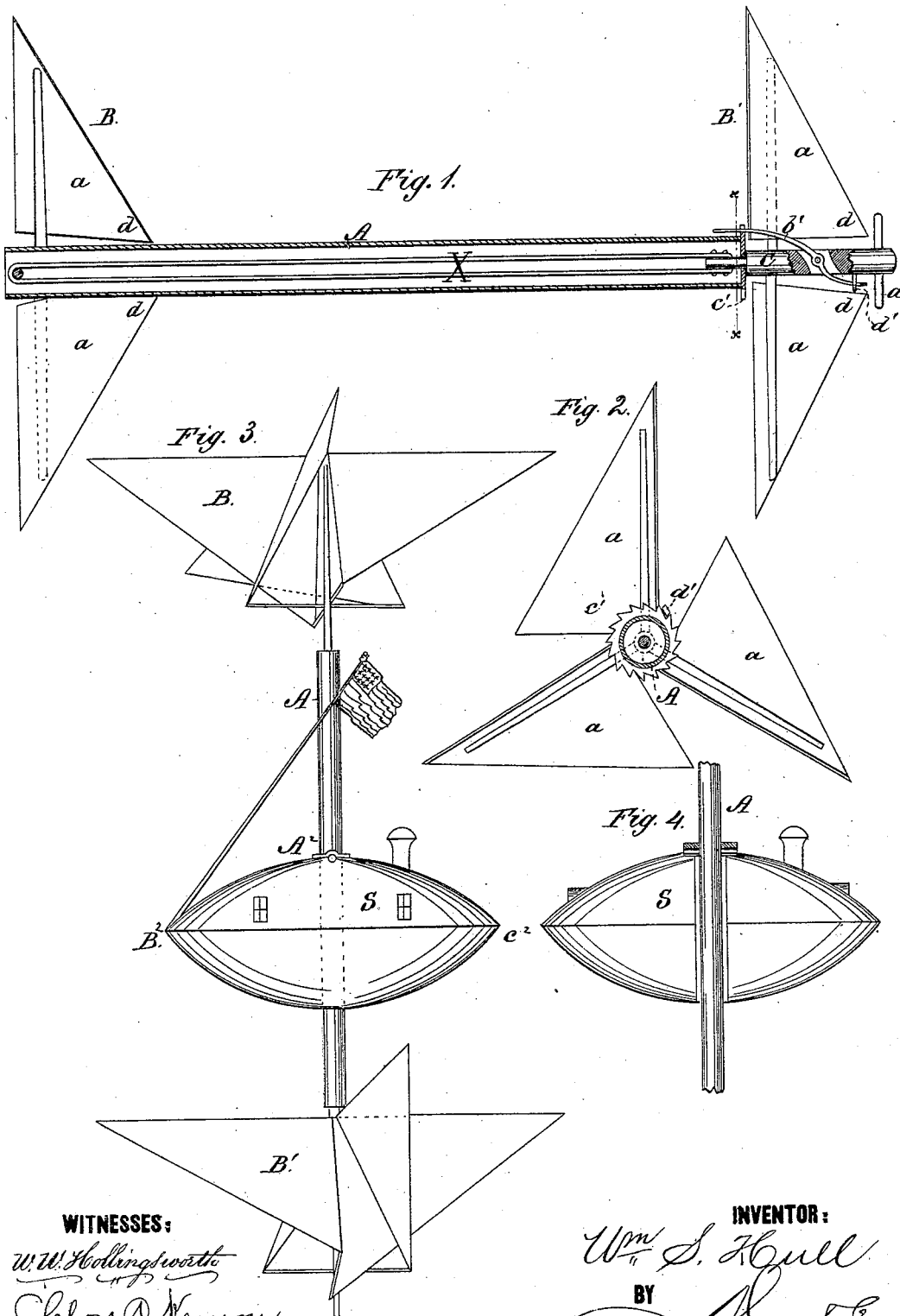

WITNESSES:

W. W. Hollingsworth
Colon Kemou

INVENTOR:

Wm S. Hull
BY *Wm R. E.*

ATTORNEYS.

UNITED STATES PATENT OFFICE.

WILLIAM S. HULL, OF JACKSON, MISSISSIPPI.

IMPROVEMENT IN FLYING TOYS.

Specification forming part of Letters Patent No. **205,617**, dated July 2, 1878; application filed March 9, 1877.

To all whom it may concern:

Be it known that I, WILLIAM S. HULL, of Jackson, in the county of Hinds and State of Mississippi, have invented a new and Improved Aerostat; and I do hereby declare that the following is a full, clear, and exact description of the same, reference being had to the accompanying drawing, forming part of this specification, in which—

Figure 1 is a longitudinal section of the aerostat arranged for a toy; Fig. 2, a transverse section through line *xx* of Fig. 1, looking from left to right. Figs. 3 and 4 are side elevations of the aerostat arranged for a flying-machine.

My invention relates to a novel construction of aerostat, the same being designed to be used either in miniature form as a toy, or upon a larger scale, with steam or other suitable motive power, as a flying-machine.

The improvement consists in the combination of reversely-arranged propellers at opposite ends of a tubular frame on a propeller-shaft with an interposed torsional spring, and a spring-catch and locking device, as will be hereinafter described.

In the drawing, my aerostat, at Fig. 1, is arranged for a toy. It consists of a tubular frame, *A*, made lightly of stiff paper or other suitable material. This tube is provided at its opposite ends with propellers *B B'*, arranged to revolve in opposite directions, the first of which is fixed upon the end of the tube itself, while *B'* is arranged upon a central shaft, *C*, revolving in bearings in the end of the tubular frame. These propellers are constructed of one, two, three, or four right-angled triangular blades or fans, *a*, one side of which fans is arranged at right angles to its driving-axis, while their larger acute angles *d* are deflected away from the said shaft. The fans of the upper and lower propellers are deflected to opposite sides of the axis, so that when revolving in different directions they shall co-operate to propel the aerostat in the same direction. The angle made by the hypotenuse of the fans with its base is preferably about that shown in the drawing; but I do not limit myself to the same, as it may be varied without departing from the invention.

With the form of propeller constructed as

thus described, I am enabled to secure a much greater lifting effect with a smaller expenditure of driving-power than I have been able to obtain by any other construction, as, while the work done is distributed in proportion to the leverage, the deflection of the rear end of the blade secures a free clearance. This form of propeller, therefore, is best adapted to the purposes of my invention, whether employed as a toy or a flying-machine. By locating the propeller also at the opposite ends of the frame, and as far apart as possible, there is less slip or loss of motive effect than can be obtained in any other way, the diminution of the said slip being in proportion to the increased distance between the said propellers.

For driving the propellers, I have connected the end of the tube carrying one propeller with the shaft at the opposite end carrying the other by means of strips of elastic india-rubber, which not only hold the rear propeller-shaft securely in its bearing, but, when twisted by any suitable means, supplies in untwisting the necessary power for driving the two propellers and elevating the aerostat in the air.

In winding up the device the tube is held in one hand, while the shaft *C* is rotated by means of a cross-pin, *a'*, a spring-catch, *b'*, serving to hold the power which is thus stored up by engaging with the teeth of a circular ratchet, *c'*, affixed to the end of the tubular frame. Now, when the device is to be given to its flight, the spring-catch *b'* is released from said ratchet, which is effected by releasing the rear end of said spring-catch from a hook, *a'*, upon shaft *C*, that holds it.

The device which has thus been described as a toy will be enlarged to carry freight and passengers. When so constructed a car, *S*, will be suspended to the tubular frame at a central point between the two fans or propellers, upon a hinge or other like device, as shown in Figs. 3 and 4, the object of which will be hereinafter described.

The car will contain a steam-engine or other driving mechanism, and will carry the passengers and freight. The car will be egg-shaped, or something approximating thereto, so that a line drawn longitudinally through the center of the car will always be parallel with the

horizon. This result will be obtained by means of the hinge before mentioned, universal joints at the points of suspension connecting the driving mechanism with the fans, and by means of a way cut through the egg-shaped car, beginning at the point of suspension A^2 , Fig. 3, extending vertically downward to B^2 , thence backward and upward to C^2 , thence upward and forward to the starting-point A^2 , making a passage-way through which the tubular frame will swing when operated by the pilot for changing the direction of the aerostat from vertical to horizontal flight, or vice versa.

The two fans before described, when the machine begins flight in a vertical direction, will, when horizontal flight is desired, thus change their position in regard to the car in a maximum of forty-five degrees, the upper fan canting downward and forward, and the lower fan canting upward and backward.

To make the machinery in the car adjust itself to the shafting in the tubular frame which connects with the fans, universal joints, flexible shafting, cams, or other devices will be used, or engines will be located upon the tubular frame, and connection will be had with the boiler upon the car through flexible piping.

Having thus described my invention, what I claim as new is—

The combination, with the tubular frame A , having one of the propellers rigidly attached thereto at one end, of the propeller-shaft C and propeller B^1 , connected with the tube by means of a torsional spring, together with a spring-catch or locking device, substantially as shown and described.

WILLIAM S. HULL.

Witnesses:

JNO. T. HULL,
E. B. COMFORT.