

W. MORRISON.
Chemical Fire-Engine.

No. 205,756.

Patented July 9, 1878.

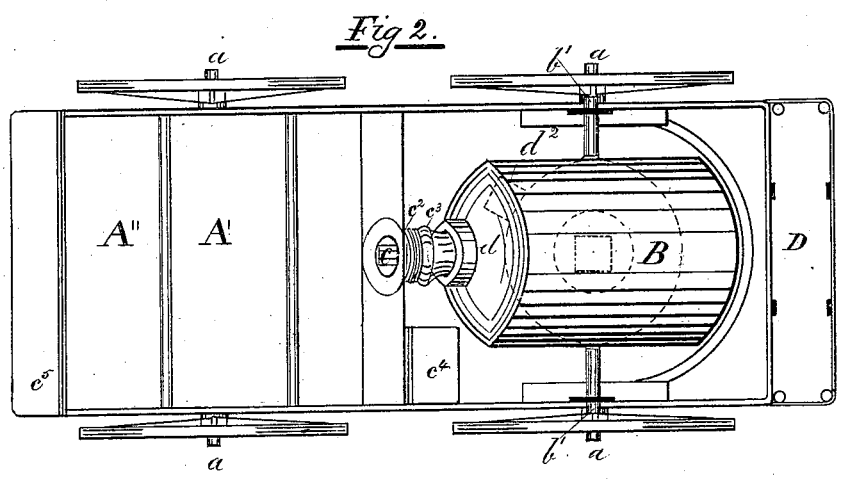
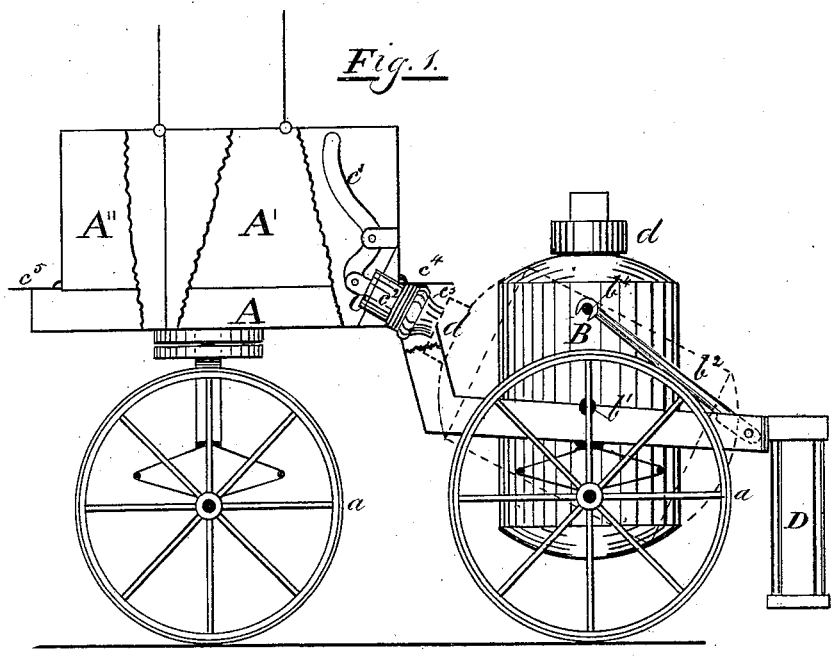

Witnesses
William Gill
Geo. Woodbridge

Inventor
W. Morrison

UNITED STATES PATENT OFFICE.

WILLIAM MORRISON, OF TORONTO, ONTARIO, CANADA.

IMPROVEMENT IN CHEMICAL FIRE-ENGINES.

Specification forming part of Letters Patent No. **205,756**, dated July 9, 1878; application filed May 27, 1878.

To all whom it may concern:

Be it known that I, WILLIAM MORRISON, of the city of Toronto, in the county of York, in the Province of Ontario, Canada, have invented certain new and useful Improvements on Chemical Fire-Engines; and I do hereby declare that the following is a full, clear, and exact description of the same.

My invention relates to chemical fire-engines which are mounted on a carriage and wheels and which are moved from place to place, either by horses or by men.

It consists, first, of a carriage constructed of any suitable material, having two or more wheels, as may be desirable; and, second, of a cylinder in which the chemicals are placed and the carbonic-acid gas is produced; and, third, in a supply-tank placed on the forward or other part of the carriage aforesaid, and at an elevation sufficient to empty, in running, its contents in the gas-producing cylinder aforesaid. This cylinder, when not in actual use, rests in an upright position and on journals, on which it revolves, in order to be charged and to be discharged.

In the accompanying drawings the same letters of reference indicate the same parts in both the views and in this specification.

Figure 1 is a sectional elevation, showing the carriage A, the supply-tank A', and cylinder B. The supply-tank A' is provided with a delivery-valve, *c*, and is operated by a lever, *c'*. It is also provided with a nozzle, *c''*, and hose-piece *c'''*, for guiding the water into the mouth *d* of the cylinder B. The tank A' is placed, in this case, on the forward part of the carriage A, and at an elevation to run out its contents into the cylinder B, the cylinder B being suspended on journals *b' b'*, which admit of its being turned partly over to receive its charge from tank A', and also to admit of its being turned fully over in an inverted position, in order to mix the water and the chemicals to produce the gas and to discharge the same. The said cylinder B, when not in use, rests in an upright position, and is secured in this position by the pivoted arm *b''*, which acts as a common latch on the stud *b'''*.

Fig. 2 is a plan or ground view, showing the carriage A, with wheels *a a a*, the tank A', with valve *c*, lever *c'*, nozzle *c''*, hose-piece *c'''*, and the compartment A'', for tools and chemicals; showing, also, the cylinder B, with journals *b' b'*, and is turned forward and receiving

the water from the tank A'. The normal position of the cylinder B is shown in this figure in dotted lines, and the branch *d''*, to which the hose is attached. There is also shown, attached to the rear end of the carriage A, the hose-hamper D, in which the hose is kept when not in use.

It will be seen, on reference to the drawings, that the invention is a new and improved mode of charging and recharging the cylinder of a chemical fire-engine.

On starting for a fire, the cylinder B is charged with its chemicals, and also with water, and by simply inverting the cylinder B the chemicals are mixed, and consequently the engine is ready to bring a stream to play on the fire when it arrives at the scene of action. The recharging-tank A' is empty when being run to a fire, but can be filled with water by means of pails, or other speedy means, from the nearest well or other convenient source of supply while the charge that is in the cylinder B is being discharged on the fire, and, when exhausted, is restored to its upright position, when the cap *d* is removed, as also the bottle, and the cylinder B tilted forward, and, by opening valve *c* in tank A' by means of handle *c'*, the charge is quickly let into cylinder B, which, when filled, is restored to its normal position. The bottle with the sulphuric acid is then inserted, the cap *d* screwed down, and the cylinder B inserted, when the engine is again ready to be discharged on the fire; and which operations can be repeated as often as may be desired.

I am aware that a box has been used in chemical fire-engines for conveying the chemicals therein; but it has not been yet applied or in use as a water-supply tank, as A' in the drawings accompanying this specification.

I claim—

The combination of the water-supply tank A', valve *c*, lever *c'*, nozzle *c''*, and hose-piece *c'''* with the tilting gas-producing cylinder B of a chemical fire-engine, by which combination and arrangement the gas-producing cylinder B is more speedily charged and recharged than by the usual practice, as specified and described.

W. MORRISON.

Witnesses:

WILLIAM GILL,
THO. THOETHIDGE,