

J. H. CARRIER, B. R. BAKER & W. McCARTY.
Washing-Machine.

No. 205,784.

Patented July 9, 1878.

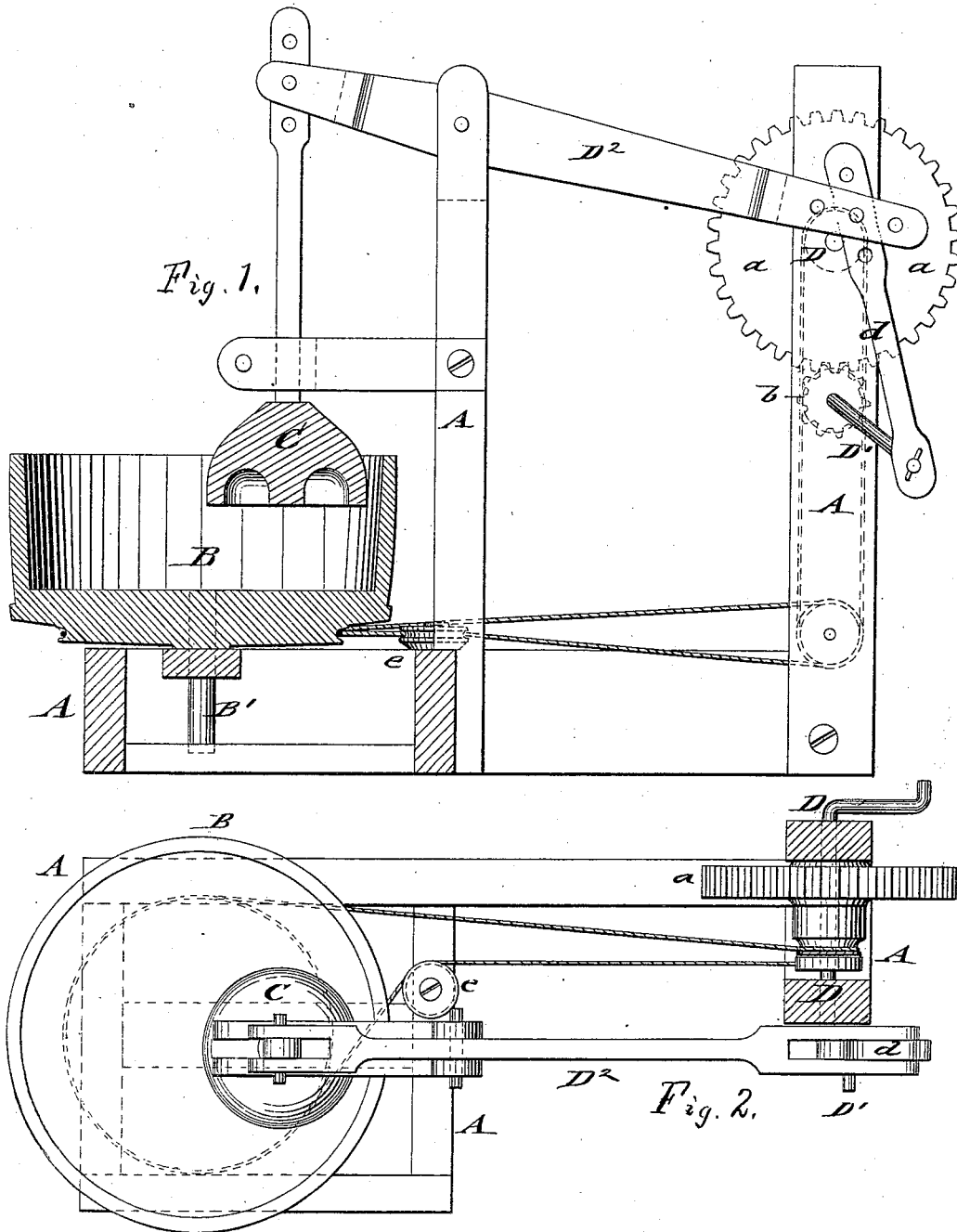

WITNESSES:

A. Schehl.
C. Sedgwick

INVENTORS.

J. H. Carrier
B. R. Baker

BY

W. McCarty
M. L. ...

ATTORNEYS.

UNITED STATES PATENT OFFICE.

JOHN H. CARRIER, BARTON R. BAKER, AND WILLIAM McCARTY, OF
LONDON, KENTUCKY.

IMPROVEMENT IN WASHING-MACHINES.

Specification forming part of Letters Patent No. **205,784**, dated July 9, 1878; application filed
April 23, 1878.

To all whom it may concern:

Be it known that we, JOHN H. CARRIER, BARTON R. BAKER, and WILLIAM McCARTY, of London, in the county of Laurel and State of Kentucky, have invented a new and Improved Washing-Machine, of which the following is a specification:

In the accompanying drawing, Figure 1 represents a sectional side elevation of our improved washing-machine; and Fig. 2, a top view of the same.

Similar letters of reference indicate corresponding parts.

This invention has reference to an improved washing-machine of that class in which a reciprocating pounder and an intermittingly-revolving tub is used.

Referring to the drawing, A represents the supporting-frame of our improved washing-machine; B, the wash-tub; and C, the pounder of the same. The wash-tub turns by a central bottom shaft, B', in bearings of the base-frame, and is revolved by suitable belt-and-pulley connection with the operating crank-shaft, the pulley of the tub being made either in one piece with the bottom of the same or attached otherwise to the shaft of the tub. To the crank-shaft D is keyed a cog-wheel, *a*, that gears with the pinion *b* of a second crank-shaft, D¹. To the outer end of the second crank-shaft D¹ is pivoted an intermediate crank-rod, *d*, which is perforated at the upper end and connected by a pivot-pin in adjustable manner with the fulcrumed operating-lever D² of the reciprocating pounder C. The front end of the operating-lever D² is pivoted to the stem of the pounder, the same being, like the crank-rod, adjustable to a greater or less

height, so as to regulate the stroke of the pounder.

The stem of the pounder is guided in a forked arm of one of the upright standards of the machine, so that a regular and reliable motion of the pounder is obtained. The pounder strikes between the center and circumference of the tub, and is provided with an annular concave cavity, so as to work in effective manner successively on all the clothes in the wash-tub, as the same revolves by the belt-and-pulley connection with the main crank-shaft.

The belt of the wash-tub is kept at a proper tension by means of an idler, *e*, so as to produce in reliable manner the simultaneous revolution of the tub with the reciprocating motion of the pounder.

We are aware that it is not new in washing-machines to use a revolving tub and reciprocating pounder, both operated simultaneously, and belt-and-pulley mechanism of a similar character to ours.

Having thus fully described our invention, we claim as new and desire to secure by Letters Patent—

A washing-machine employing a pounder and rotary tub, and having its pounder-stem operated by means of the lever D², crank-rod *d*, crank-shaft D¹, pinion *b*, and crank-shaft D, having cog-wheel *a*, all arranged substantially as shown and described.

JOHN HENDERSON CARRIER.
BARTON RUSSELL BAKER.
WILLIAM McCARTY.

Witnesses:

JAMES DEES,
JOHN CHESNUT.