

J. H. GABLE.  
Condenser for Steam-Engines.

No. 205,793.

Patented July 9, 1878.

*Fig. 1.*

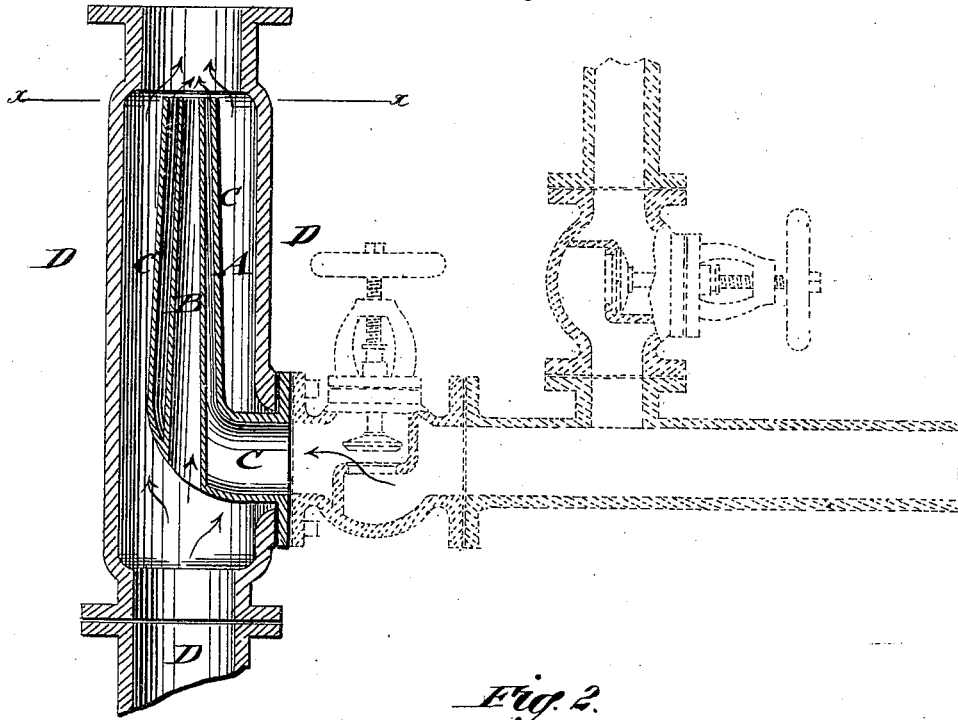

*Fig. 2.*

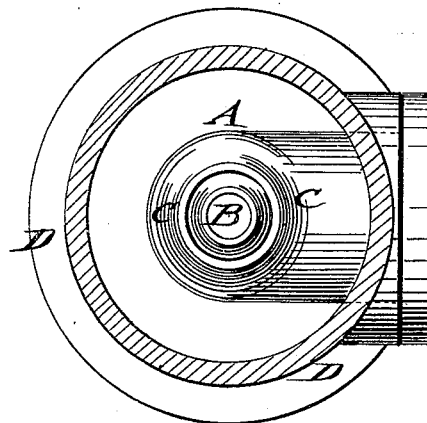

WITNESSES:

*Francis McArthur.*  
*C. Sedgwick*

INVENTOR:

*J. H. Gable*  
BY *Munn & Co*

ATTORNEYS.

# UNITED STATES PATENT OFFICE.

JOHN H. GABLE, OF SHAMOKIN, PENNSYLVANIA.

## IMPROVEMENT IN CONDENSERS FOR STEAM-ENGINES.

Specification forming part of Letters Patent No. **205,793**, dated July 9, 1878; application filed June 3, 1878.

*To all whom it may concern:*

Be it known that I, JOHN H. GABLE, of Shamokin, in the county of Northumberland and State of Pennsylvania, have invented a new and Improved Condenser for Steam-Cylinders, of which the following is a specification:

In the accompanying drawing, Figure 1 represents a vertical central section of my improved condenser for steam-cylinders, and Fig. 2 a horizontal section of the same on line *x x*, Fig. 1.

Similar letters of reference indicate corresponding parts.

This invention relates to a simple and effective condenser for steam-cylinders of all kinds, in which a current of water is employed to condense the exhaust-steam, and create thereby a vacuum that facilitates the running of the steam-engine or pump and gives it a greater percentage of power; and the invention consists of a condenser consisting of an inner tube passing through an outer tube connected to the end of the exhaust-pipe, and placed either into the receiving or suction pipe of a pump, or into any pipe through which a current of water passes that condenses the exhaust-steam in the space between the condensing-tubes.

Referring to the drawing, A represents my improved condenser for steam-cylinders, which is made of an inner tube, B, that passes through an outer tube, C, so as to be capable of conducting a current of water through the interior of the condenser.

The outer tube C is attached in any suitable position to the end of the exhaust-pipe of a steam-cylinder, the exhaust-pipe being provided with two stop-valves, as indicated in dotted lines in Fig. 1, so as to shut off the condenser from the exhaust-pipe and exhaust when it is desired to exhaust in the common manner.

The condenser A is arranged at the inside of a pipe, D, through which a current of water passes, the pipe D being either the receiving or suction pipe of a pump; or it may be fastened to the side of a steam-vessel, so that a current of water is forced through pipe D, or so placed that a running stream or any other current of water may be utilized. In either case the water passes through the inner and around the outer tube of the condenser, and condenses the steam in the narrow space between the double tubes, so as to cause a vacuum therein and in the exhaust-pipe, which will give an increase of power to the cylinder. The quicker the water passes through the condenser the more rapid will be the condensation of the steam and the greater the gain in power of the cylinder.

The condenser may be used in connection with the steam-cylinder of any engine or pump, provided the required current of water can be supplied to the double tubes of the condenser, and thereby the more effective working of the steam-cylinder by the condensation of the exhaust-steam obtained.

I am aware that it is not broadly new to condense steam between two streams of water; but

What I claim is—

A tube, C, having an open-ended pipe, B, passing centrally through the straight part thereof, and in one piece therewith, as shown and described, to adapt it to be inserted in a water-pipe, the receiving or suction pipe of a pump, at the side of a vessel, or in a stream of running water, for the purpose specified.

JOHN H. GABLE.

Witnesses:

W. H. GILGER,  
URIAH SOBER.