

E. MOOG.
 Clearing Attachment for Carding-Machines.
 No. 205,805. Patented July 9, 1878.

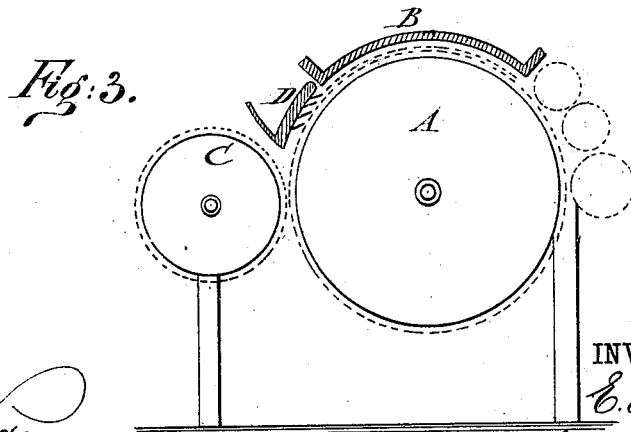
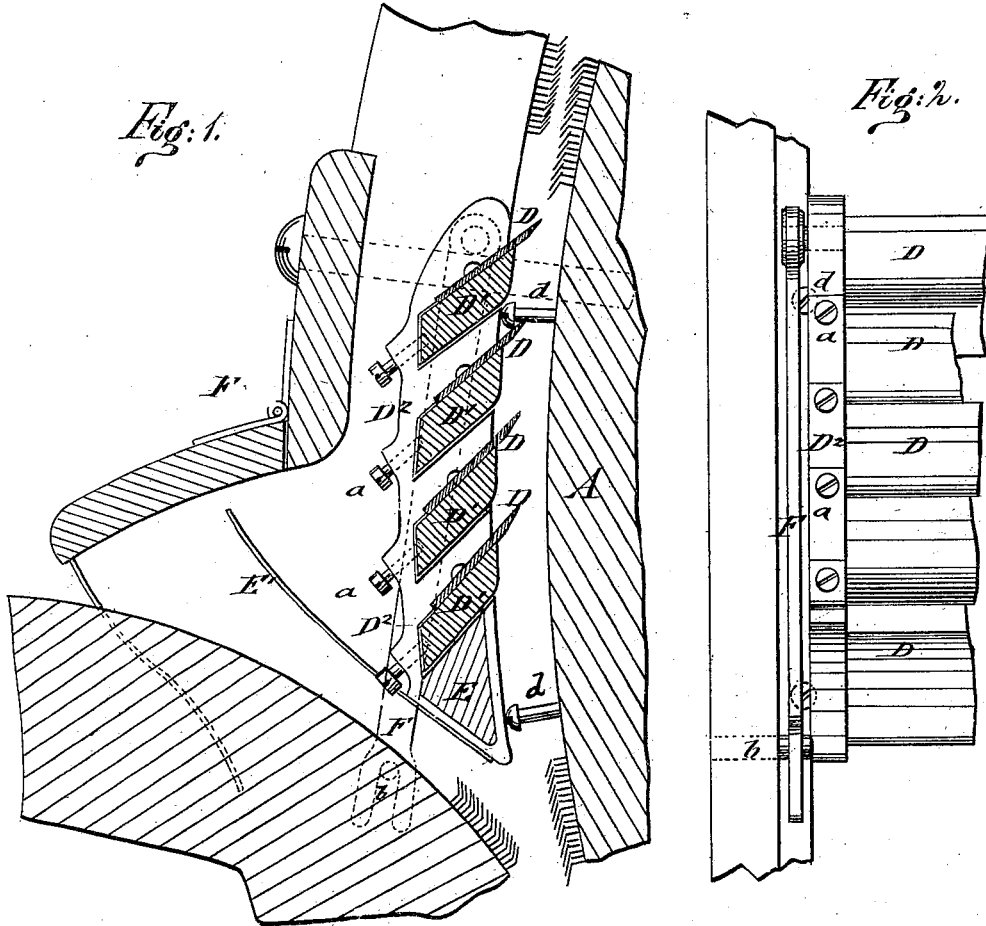

WITNESSES:
Cras Nida
J. H. Scarborough

INVENTOR:
E. Moog
 BY *[Signature]*
 ATTORNEYS.

UNITED STATES PATENT OFFICE.

EGIDI MOOG, OF OGGERSHEIM, BAVARIA, GERMANY.

IMPROVEMENT IN CLEARING ATTACHMENTS FOR CARDING-MACHINES.

Specification forming part of Letters Patent No. **205,805**, dated July 9, 1878; application filed November 30, 1877.

To all whom it may concern:

Be it known that I, EGIDI MOOG, of Oggersheim, in the Kingdom of Bavaria and Empire of Germany, have invented a new and Improved Clearing Attachment to Carding-Machines, of which the following is a specification:

In the accompanying drawing, Figure 1 is a sectional elevation of the clearing attachment on a large scale. Fig. 2 is a front view of a portion of the same. Fig. 3 is a section of a carding-machine on a small scale, showing position of my improved attachment in relation to the main cylinder, top cards, and doffer.

Similar letters of reference indicate corresponding parts.

The invention relates to a clearing attachment for carding-machines, which is designed to be placed into the space between the top cards, doffer, and main cylinder of the machine for acting on the surface of said cylinder.

The invention consists in the construction of the attachment and the means for supporting the same in position, as will be hereinafter more fully described, and then set forth in the claims.

By referring to the drawing, A represents the main cylinder, B the top cards or top flats, and C the doffer, of a carding-machine of the usual construction.

In the triangular space formed between main cylinder, top cards, and doffer I arrange my improved clearing attachment, which consists of scraping-knives D, which are attached to wooden rails or blocks D¹, that are let into recesses of the cast-iron side pieces D² of the attachment. The knives and rails extend the whole length of the main cylinder, and are placed at an angle of about forty-five degrees to the circumference of the same.

The scraping-knives D are made of steel plates of suitable thickness, and well hardened to prevent their wearing out, they being provided with a sharp edge at the end next to the cards of the main cylinder.

The knives D are adjusted nearer to or farther from the main cylinder by means of regulating-screws a, which pass through the side pieces D² and bear on the rear parts of the sliding rails D¹. By the use of these screws

one or all of the knives may be regulated with the greatest ease while the machine is at work. The degree of adjustment has to be according to the length and quality of the cotton, and has to be determined by actual tests in each case.

Below the lowermost knife-block is arranged a wooden connecting-piece, E, of triangular shape, which serves to fill out the empty space between the main cylinder and doffer, and to support the collecting-trough E'.

The entire clearing attachment is supported on arms F, which are pivoted by their upper ends to the upper parts of the side pieces D², and applied by their lower forked ends to fixed bolts b of the side frame of the carding-machine. The arms F swing on the bolts b, and serve to carry the attachment into position toward the main cylinder.

The side pieces D² bear by side flanges on wood-screws d, that are screwed into the lining between the main cylinder and the frame of the carding-machine, the wood-screws retaining the clearing attachment at the proper distance from the cards.

To the side frame of the carding-machine is attached a wooden casing, F, or dust-cover, that extends over the entire apparatus and back to the doffer, the cover being made of a fixed section, attached to the concave shell of the top flats, and of a hinged section that may be conveniently thrown up for the purpose of adjusting the scraping-knives or entire attachment.

This clearing mechanism may be attached with equal facility to old or new carding-machines by merely screwing the supporting-bolts and regulating-screws in position, and placing then the attachment in position on the same.

The scraping-knives serve to detach the tufts and knots from the cotton forced against them by the cards of the main cylinder, and to collect them in the trough, which is emptied from time to time by taking off the entire device from its supports. Any adhering impurities that escape the top cards are thus reliably removed by the clearing attachment, and a more uniform fleece or layer of cotton furnished for the successive treatment.

Having thus described my invention, I claim

as new and desire to secure by Letters Patent—

1. The clearing attachment for carding-machines, consisting of the grooved side pieces D², bottom connecting-piece E, rear collecting-trough E', pivoted supporting-arms F, and adjustable rails and knives D¹ D, all constructed as herein described, and adapted for use in the manner set forth.

2. The combination of the pivoted arms, having forked lower ends, with the clearing

attachment D² D¹ D E, for adjustably hanging said attachment to the frame of a carding-machine, and holding it in proper relation to the carding-cylinder, as herein set forth.

In testimony that I claim the foregoing I have hereunto set my hand this 2d day of September, 1877.

E. MOOG.

Witnesses:

SCHUTT,

C. W. ALTIERY.