

H. ADLER.
Fender-Bar.

No. 205,821.

Patented July 9, 1878.

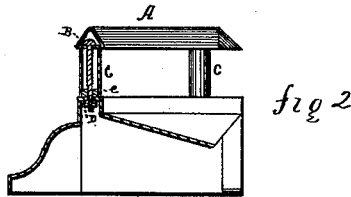
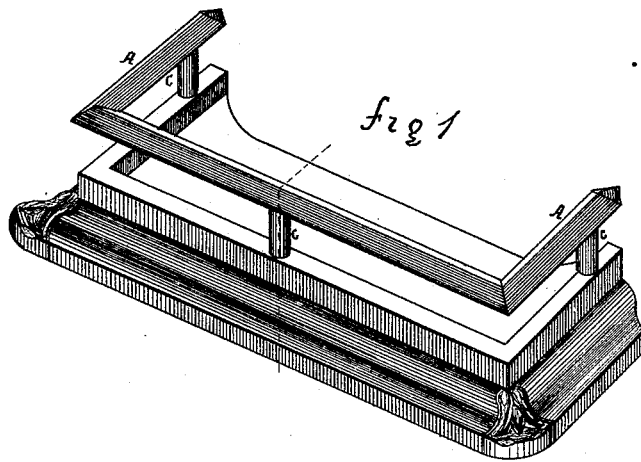

Witnesses
A. J. Davis
B. L. Johnson

Inventor
Henry Adler
by *A. L. Johnson*
att'y

UNITED STATES PATENT OFFICE.

HENRY ADLER, OF PITTSBURG, PENNSYLVANIA.

IMPROVEMENT IN FENDER-BARS.

Specification forming part of Letters Patent No. **205,821**, dated July 9, 1878; application filed December 26, 1877.

To all whom it may concern:

Be it known that I, HENRY ADLER, of Pittsburg, in the county of Allegheny and State of Pennsylvania, have invented a new and useful Improvement in Fender-Bars; and I do hereby declare that the following is a full and exact description thereof, reference being had to the accompanying drawings, and to the letters of reference marked thereon.

My invention relates to an improvement in fender-bars; and consists in providing its under surface with a recess or recesses for the reception of the head of a screw-bolt of the posts upon which the fender-bar rests, whereby the fender-bar and its posts may readily be secured to the fender.

My invention also consists in a hollow post provided with a screw-nut for the bolt, used for locking the posts and fender-bar to the fender.

To enable others skilled in the art to make my invention, I will describe its construction.

Figure 1 is a perspective view of the fender-bar and its posts secured in position on a fender, and Fig. 2 is a vertical section of the fender-bar, posts, bolts, and fender.

In the drawings, A represents the fender-bar, the under side of which is furnished with a groove for the reception of the head of the bolt B, which bolt passes down through the hollow post C, the lower end of which is furnished with a screw-nut, *e*. The bolt also passes through an opening made in the fender, and is secured to the fender by means of a screw-nut, D, on the lower end of the bolt B.

By means of the groove or recess in the fender-bar, the position of the post may be adjusted so that the bolt B may, with ease and facility, enter the opening in the fender, and the post C and bar A secured in position on the fender by the nut D.

By constructing a fender-bar and its posts as hereinbefore described, they may be secured to the fender without trouble, and without straining either the bar or posts in the operation of securing them on and to the fender, which is a very great advantage in connection with a fender constructed of sheet metal, it being necessary to secure the bar and posts to the fender without undue strain; otherwise the fender would be twisted and warped, which twisting and warping is very objectionable.

Having thus described the nature and construction of my improvement, what I claim, and desire to secure by Letters Patent, is—

1. A fender-bar provided on its under surface with a recess or recesses for the reception of the head of a screw-bolt, whereby said fender-bar and its posts may be secured to the fender, substantially as herein described, and for the purpose set forth.

2. A hollow post for a fender-bar, provided with a screw-nut, in combination with a bolt and screw-nut for uniting the fender-bar with the fender, substantially as and for the purpose set forth.

HENRY ADLER.

Witnesses:

A. C. JOHNSTON,
B. L. JOHNSTON.