

BEST AVAILABLE COPY

C. L. BAYRD & S. PAUL.  
Music-Leaf Turner.

No. 205,826.

Patented July 9, 1878.

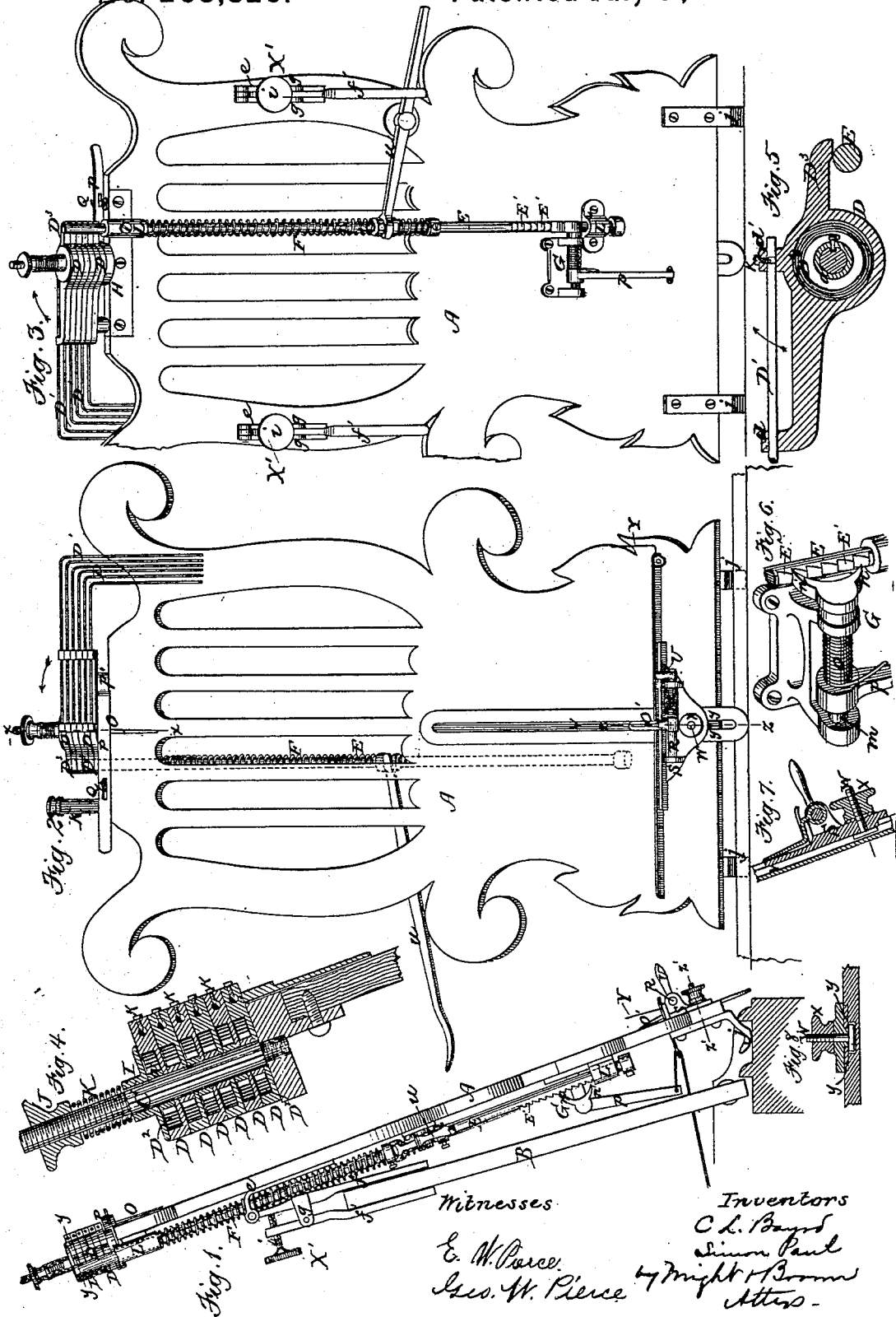

Witnesses  
E. W. Pierce  
Geo. W. Pierce

Inventors  
C. L. Bayrd  
Simon Paul  
by Wright & Brown  
Attors.

# UNITED STATES PATENT OFFICE.

CHARLES L. BAYRD, OF WAKEFIELD, AND SIMON PAUL, OF WALTHAM,  
MASSACHUSETTS.

## IMPROVEMENT IN MUSIC-LEAF TURNERS.

Specification forming part of Letters Patent No. 205,826, dated July 9, 1878; application filed  
January 23, 1878.

*To all whom it may concern:*

Be it known that we, CHARLES L. BAYRD, of Wakefield, in the county of Middlesex, and SIMON PAUL, of Waltham, in the county of Middlesex and State of Massachusetts, have invented certain Improvements in Music-Leaf Turners, of which the following is a specification:

This invention has for its object to provide an effective and easily-operated music-leaf turner which can be attached to the music-rack of a piano or other musical instrument; and to this end it consists in the construction and combinations of the various parts, which we will now proceed to describe.

Of the accompanying drawing, forming part of this specification, Figure 1 represents an edge view of my improved music-leaf turner applied to the music-rack of a piano. Fig. 2 represents a front view of the same. Fig. 3 represents a rear view of the same. Fig. 4 represents a section on line *xx*, Fig. 2. Fig. 5 represents a section on line *yy*, Fig. 1. Fig. 6 represents a perspective view of the escapement. Fig. 7 represents a section on line *zz*, Fig. 2. Fig. 8 represents a section on line *z'z'*, Fig. 1.

Similar letters of reference refer to like parts in all the figures.

In the drawing, A represents the rack or support, which is preferably made of wood, in the shape of a lyre, or in any suitable design. This rack is provided with three general attachments—viz., leaf-turning mechanism, adapted to turn sheets or leaves of music placed upon the rack; leaf holding or clamping mechanism, adapted to secure the sheets or leaves to the rack; and devices whereby the rack may be attached to the permanent music-rack B of a piano.

The leaf-turning mechanism is composed of the following elements, viz: First, a stationary bearing-pin, C, suitably attached to the upper end of the rack A, and projecting upwardly therefrom; second, a series of hubs or base-pieces, D, which are journaled on the bearing-pin C so as to revolve thereon, each carrying a pivoted turning-finger, D<sup>1</sup>, and a spring, D<sup>2</sup>, adapted to impel or rotate the hub and its finger in the direction indicated by the

arrows in Figs. 2, 3, and 5; third, a sliding stop-pin, E, adapted to hold the base-pieces D and their fingers D<sup>1</sup> against the force of the springs D<sup>2</sup>, and to release said hubs and fingers independently; fourth, a spring, F, whereby the pin E is automatically depressed; and, fifth, an escapement, G, under the control of the operator, adapted to regulate the automatic depression of the pin E in such manner as to cause the latter to release the base-pieces D and their fingers D<sup>1</sup> one at a time, the stop-pin being provided with ratchet-teeth, E<sup>1</sup>. The bearing-pin C is preferably secured into a flanged bracket or casting, H, which is attached to the upper end of the rack A.

The hubs or base-pieces D are each composed of a circular portion, having a central orifice to receive the pin C; an annular chamber, surrounding the pin C and containing the coiled spring D<sup>2</sup>; two bearings, *d d'*, for the turning-finger D<sup>1</sup>; and an arm or abutment, D<sup>3</sup>, to bear against the stop-pin E before the base-pieces and turning-fingers are released by said stop-pin.

The spring D<sup>2</sup> is attached at one end to the hub or base-piece D and at its other end to a collar, *a*, which is keyed to the bearing-pin. Any desired number of base-pieces may be employed, and the series are held downwardly by a plate or washer, I, a nut, J, and an interposed spring, K, applied to the upper end of the bearing-pin, which is threaded.

Each turning-finger D<sup>1</sup> is composed preferably of an angular or curved wire, arranged to extend horizontally through the bearings of its base-piece or hub D, and project downwardly at its outer end over the outer surface of the rack A, to be interposed between the sheets or leaves of music.

The fingers D<sup>1</sup> are adapted to vibrate in their bearings, so that they can swing outwardly from the surface of the rack A when arranged as shown in Figs. 2 and 3, (this being the position they occupy before being released by the stop-pin E;) but as it is necessary that they shall not swing in the opposite direction when in the act of turning the leaves, I provide each finger with a stopping device adapted to prevent it from turning backwardly, but allowing it to swing out-

wardly when in the position shown, such device consisting, in the present instance, of a pin or screw, K, entering one of the bearings of the finger, and projecting into a recess or scarf cut in the finger, the pin or screw K having a pointed end, and serving at once to prevent the backward swinging or rotation of the finger and the longitudinal movement of the same in its bearings.

The stop-pin E is arranged to slide longitudinally in bearings L L on the rear side of the rack A.

The spring F, whereby the pin E is automatically depressed, is interposed between the bearing L and a fixed collar attached to the lower portion of the pin.

The ratchet-teeth E' are so spaced that the distance between each and the one following is equal to the length of movement of the pin E required to release one of the base-pieces D.

The escapement G is composed of a rock-shaft, *m*, journaled in bearings attached to the back of the rack A; a double pawl, composed of two arms or points, *n n'*, rigidly attached to said rock-shaft; a spring, *o*, applied to the shaft, to hold the arm *n* of the double pawl in yielding contact with the ratchet-teeth E'; and a lever, *p*, rigidly attached to the rock-shaft, and held away from the rack A by the spring *o*, and connected, by a cord or otherwise, with a treadle or other means for moving said arm against the force of the spring *o*.

When the stop-pin E is elevated and held by the arm *n'* of the double pawl, a downward movement of the lever *p* will move the arm *n'* away from the pin E, and at the same time move the arm *n* into contact with said pin. The space between the points of the arms *n n'* is such that this operation causes the pin E to be released by the arm *n'* and forced downwardly by its spring about half the length of one of the ratchet-teeth, when it will be caught and supported by the engagement of the arm *n* with a tooth below the one released. Then, the lever *p* being released, the spring *o* will remove the arm *n* from contact with the pin E, thus releasing the same, and at the same time forcing the arm *n'* into contact with said pin, and causing the arm *n'* to arrest the next tooth above and again support the pin E, the two movements thus effected being equal to the length of one of the ratchet-teeth, and hence resulting in the release of one of the base-pieces D and fingers D<sup>1</sup>.

The leaf holding or clamping mechanism is composed of two clamps, O O', one located at the top and the other at or near the bottom of the rack A, on the front side thereof. The upper clamp O is composed of a finger, preferably attached to an arm, P, which is pivoted at *p'* to the upper end of the rack A, and is adapted to be held in contact with the front surface of the rack by a latch or hook, Q.

By disconnecting the arm P from the latch

Q, the clamp O may be removed from the surface of the rack A.

The lower clamp O' is preferably composed of a finger rigidly attached to a shaft, R, which is journaled in bearings on a bracket or plate, S, and is provided with a spring, T, which forces the finger O' toward the surface of the rack A, and with a handle, U, by which to turn the finger O' away from the rack A. The bracket or plate S is extended on each side, to form a shelf or support for the lower ends of the leaves or sheets of music which are placed against the rack A, and are then secured by bringing the clamps O O' to bear upon them.

I prefer to make the bracket S and clamp O' adjustable vertically, and to this end provide the rack A with a vertical groove or guide, V, and adapt the bracket to slide in this guide, the bracket being provided with a projecting lug, which lies in the guide.

W represents a screw, having an enlarged head, which lies in the inner portion of the guide V, the latter being T-shaped in cross-section. This screw passes through the bracket S, and is provided with a nut, X. By screwing down the nut X the head of the screw W will be clamped against the lip or flange *y*, which surrounds the guide V, and thus the bracket S will be firmly held.

It will be seen that by the described arrangement sheets or leaves of different lengths can be applied and secured to the rack A.

I do not limit myself to the precise construction of the clamps, as they may be varied as desired.

I provide the bracket S with a yielding pivoted finger, Y, of wire, adapted to bear against the leaves or sheets of music with a yielding pressure, and prevent the leaf following the one being turned from being carried over accidentally, said finger bearing against the outer surface of the outer unturned leaf—that is to say, the leaf at the right of the operator—and being arranged to yield when the leaf against which it bears is turned by its turning-finger, and to regain its position and bear against the succeeding leaf, to prevent the latter from being turned by the atmospheric pressure induced by the turning of the preceding leaf.

The devices for attaching the rack A and its attachments to the permanent music-rack of a piano consist, preferably, of two clamps, X', each composed of a bearing-piece or support, *e*, rigidly attached to the back side of the rack A, a jaw, *f*, pivoted to said bearing-piece, and provided with lugs *g g*, and a jaw, *f'*, pivoted to the lugs *g*, and provided with a screw, *i*, which bears against the jaw *f*, as shown in Fig. 1. When the clamps are applied to the permanent rack B of the piano, they are caused to grasp the same tightly by turning the screws *i*.

The rack is provided with feet *j j*, which are preferably coated with some soft material, as also the jaws *f f'*, and these feet rest against

the ledge of the piano above the key-board, as shown in Fig. 1.

Operation: The rack A being secured to the piano, the operator clamps the music leaves or sheets thereto by the clamps O O', turns the base-pieces D and turning-fingers D<sup>1</sup> into the position shown in Figs. 1, 2, and 3, elevates the stop-pin E, and interposes the fingers D<sup>1</sup> between the sheets or leaves to be turned.

When the operator desires to turn a leaf, he gives a slight movement to the lever *p*, the result being a depression of the pin E sufficient to release one base-piece D, the spring of which forces it, with its finger D<sup>1</sup>, over toward the left of the operator until the finger D<sup>1</sup> strikes a stop, K, which is preferably located on the upper end of the rack A, as shown in Fig. 2. This motion of the finger, turning the leaf at every repetition of the movement of the lever *p*, releases base-piece and finger until all are released.

When the stop-pin E has been entirely depressed, it is raised by a lever, *u*, pivoted to the back side of the rack A.

It will be seen that the clamps X' for attaching the rack A to the music-rack of a piano, being hinged to the rack A, enable the same to be inclined at different angles, so that the music can be held at any desired angle or inclination, and the rack A can be accommodated to the distance between the top of the music-rack of the piano and the ledge on which the feet *j* rest, be such distance greater or less.

We claim as our invention—

1. In a music-leaf turner, the combination of a stationary bearing-pin, a series of hubs or base-pieces journaled thereon, each carrying a pivoted finger arranged to turn in its bearing, a series of springs whereby the hubs and fingers are independently impelled, a stop-pin whereby one or all of the hubs and fingers are held in position to turn the music-leaves when released, and mechanism, substantially as described, actuating the stop-pin to independently release the hubs and turning-fingers, as set forth.

2. In a music-leaf turner employing a series of spring-impelled hubs, D, journaled on a stationary bearing-pin, C, at the upper end of a rack or support, A, and a series of pivoted fingers, D<sup>1</sup>, depending from said hubs, the combination, with said hubs and turning-fingers, of a ratcheted stop-pin, E, located on the rack or support, impelled downwardly by a spring, F, and regulated in its descent by an escapement, G, substantially as described.

3. In combination with the rack or support A, provided with leaf-turning mechanism, substantially as described, located at its upper end, the clamp O, also located at the upper end of the rack or support, and the vertically-adjustable clamp O', located below the clamp O, substantially as and for the purpose specified.

4. In combination with the rack or support A, having the slot or guide V, the adjustable shelf or bracket S, arranged to be held and guided in the slot, and provided with a clamp, O', for holding the sheets or leaves of music, and suitable locking devices, whereby the shelf or bracket is held at any desired height, substantially as described.

5. In combination with the shelf or bracket S, the shaft R, having the clamping-finger O', spring T, and lever V, as set forth.

6. In combination with a music-leaf turner having spring-impelled turning-fingers, the spring finger or detent Y, arranged to bear against the outer surface of an unturned leaf with a yielding pressure, said finger being adapted to yield to allow the leaf to turn when its turning-finger is released, and to regain its position to prevent the turning of the succeeding leaf, as set forth.

7. The combination of the spring-impelled hubs or base-pieces D, provided with bearings *d d'*, the angular depending fingers D<sup>1</sup>, arranged to vibrate in said bearings, and stops K, whereby the vibration of said turning-fingers in one direction is limited, substantially as and for the purpose specified.

8. The combination of the chambered hubs or base-pieces D, constructed as described, the coiled springs D<sup>2</sup>, the bearing-pin C, and the sliding stop-pin E, as set forth.

9. The stop-pin E, having ratchet-teeth E', and adapted to be automatically depressed by a spring, F, combined with the hubs or base-pieces D, and the spring-escapement G, substantially as described.

10. In combination with the stop-pin E, the lever *u*, whereby said pin is elevated, as set forth.

11. In combination with the rack or support A, the clamps X' X', pivoted to the back of said rack, and arranged to grasp the music-rack of a piano, whereby the rack or support is enabled to be inclined at different angles, as set forth.

12. The escapement G, consisting of the rock-shaft *m*, pawls *u u'*, spring *o*, and lever *p*, combined with the downwardly-impelled ratcheted pin E, substantially as described.

13. In combination with the rack or support, the clamps X', each composed of the following elements, to wit: a bearing-piece, *e*, rigidly attached to the rack or support A; a jaw, *f*, pivoted to said bearing-piece and provided with lugs *g g*; and a jaw, *f'*, pivoted to said lugs and provided with a screw, *i*, substantially as described.

In testimony whereof we have signed our names to this specification in the presence of two subscribing witnesses.

CHARLES L. BAYRD.  
SIMON PAUL.

Witnesses:

GEO. W. PIERCE,  
C. F. BROWN.