

R. D. CHATTERTON.  
Car-Coupling.

No. 205,838.

Patented July 9, 1878.

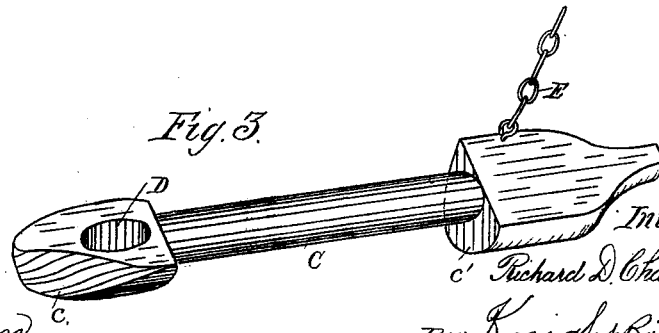
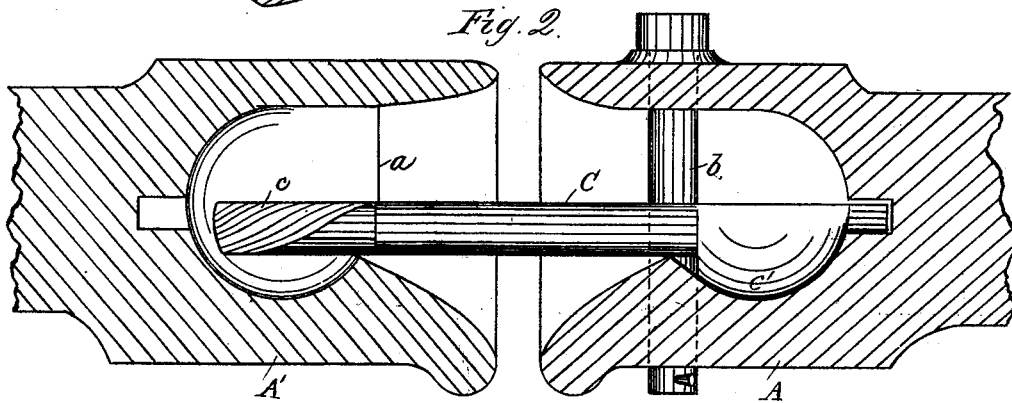
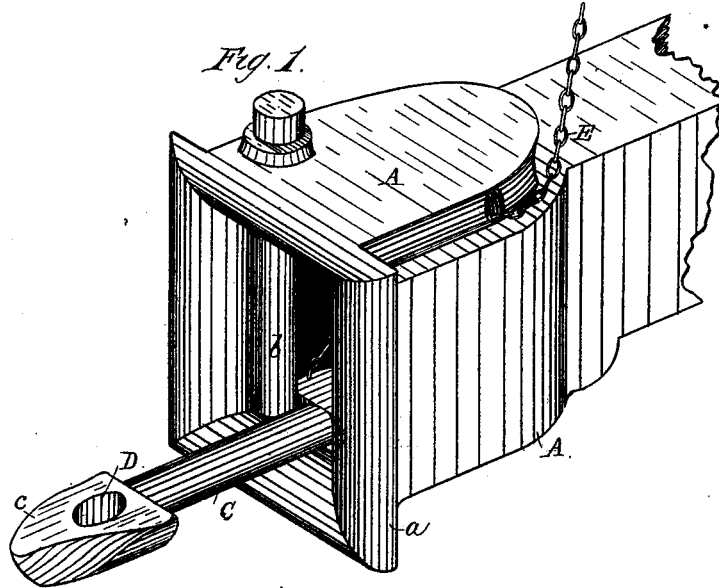

Attest  
Geo. T. Smallwood Jr.  
Walter Allen

Inventor:  
Richard D. Chatterton.  
By Knight & Pines Atty.

# UNITED STATES PATENT OFFICE.

RICHARD D. CHATTERTON, OF COBOURG, ONTARIO, CANADA.

## IMPROVEMENT IN CAR-COUPPLINGS.

Specification forming part of Letters Patent No. 205,838, dated July 9, 1878; application filed June 4, 1878.

*To all whom it may concern:*

Be it known that I, RICHARD DOVER CHATTERTON, of Cobourg, in the Province of Ontario and Dominion of Canada, have invented a new and useful Improvement in Car-Couplings, of which the following is a specification:

Using an ordinary railway draw-head, I substitute for the central holding-pin two vertical side jaws within the mouth-piece, and for the link a strong loose iron bar having at its connecting end a stout spiral or screw-pointed arrow-head of sufficient size to contain within it an opening or small link for convenience in coupling, when necessary, with cars fitted with a common link and pin. At the other end of said bar is an eccentric counterpoise-weight, which, in coupling, is turned up edgewise by the partial rotation of the bar from the action of the screw until its head passes between the holding-jaws, and then is instantly restored to its holding position by gravity. A chain attached to the counter-weight is employed to draw it up to release the head in uncoupling.

In order that my invention may be clearly understood, I will proceed to describe it with reference to the accompanying drawings, in which—

Figure 1 is a perspective view of a draw-head with the coupling-bar in position. Fig. 2 is a longitudinal section of two draw-heads connected by the coupling-bar. Fig. 3 is a perspective view of the coupling-bar detached.

A A' are two draw-heads provided with holding-jaws, one of which may be stationary, as at *a*. The other is preferably in the form of a vertical removable pin, *b*. C is my improved coupling-bar, constructed with a spiral or screw-shaped arrow-head, *c*, adapted to enter between the jaws *a b*, turning the bar C in so doing, and, when the bar turns back to its normal position, to catch and hold securely behind said jaws. To cause the bar to automatically assume and retain this locked posi-

tion, its rear end is constructed with an eccentric counterpoise-weight, *c'*. D represents a slot or hole in the head *c* of the bar to adapt it to receive a common coupling-pin when used with a car not provided with my improved coupling. E is a chain or cord extending obliquely upward through an opening in the draw-head, and carried to the top or side of the car for use to turn up the counter-weight *c'*, thereby turning the holding-shoulders of the head *c* into vertical position and permitting the head to be withdrawn freely from the draw-head A'.

The removal of the pin *b* permits the passage of the counter-weight *c'*, so that the bar may be taken completely out for changing it from one draw-head to another, or for repairs or any other purpose. In ordinary use the pin *b* is not disturbed. The counter-weight *c'* serves also to support the bar in horizontal position in readiness to enter the draw-head.

My improved coupling is cheap, simple, durable, and sure, and operates easily and effectively, even with cars of varying height.

Having thus described my invention, what I claim as new therein, and desire to secure by Letters Patent, is—

1. The bar C, constructed and operating as described, with spiral or screw-shaped arrow-head *c* and counter-weight *c'*, in combination with the draw-head A, provided with jaws *a b*, one removable, as and for the purposes set forth.

2. The combination of the bar C, constructed with spiral arrow-head *c* and counter-weight *c'*, the draw-heads A A', provided with holding-jaws *a b*, and the chain E for turning the draw-bar to release it, all substantially as herein described.

R. D. CHATTERTON.

Witnesses:

R. RUTTAN,  
ROE BUCK.