

H. DORPMÜLLER.
Speed-Recorder.

No. 205,844.

Patented July 9, 1878.

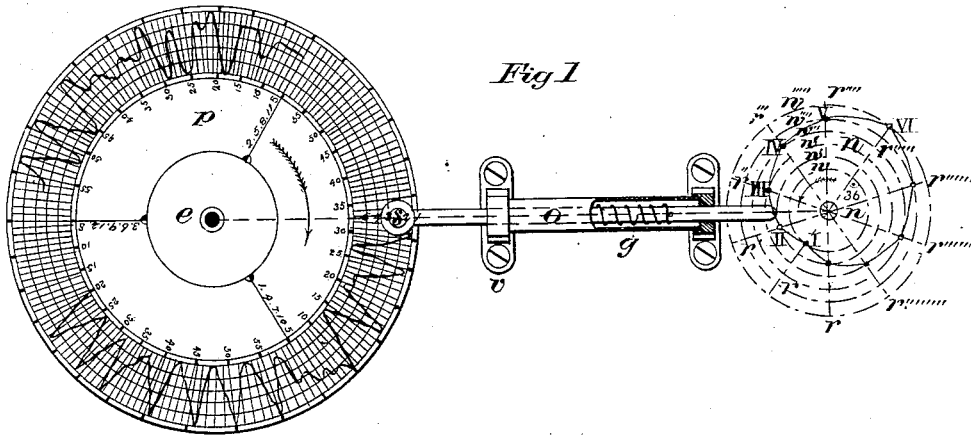

Fig 1

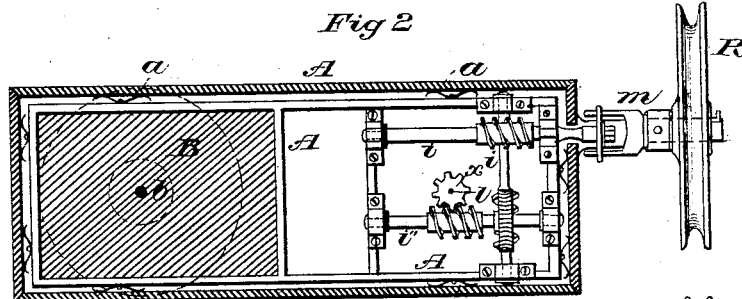

Fig 2

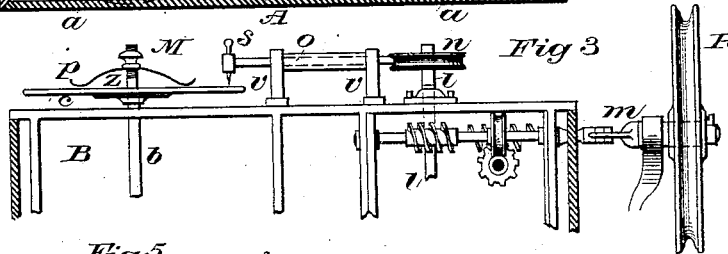

Fig 3

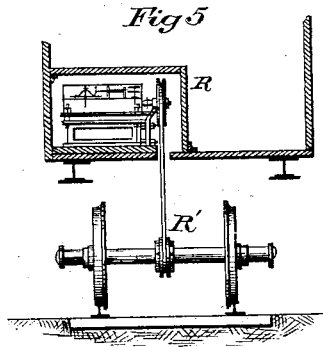

Fig 5

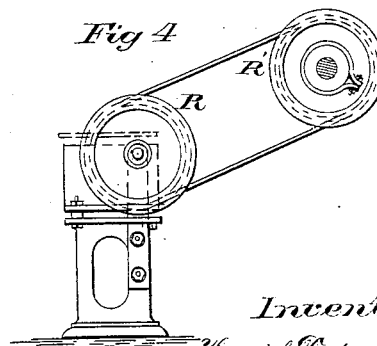

Fig 4

Witnesses:

E. Volkmann
H. Meyer

Inventor:

Herrich-Dorpmüller
by Ernst Birkhäuser
his Attorney.

UNITED STATES PATENT OFFICE.

HEINRICH DORPMÜLLER, OF MUNICH-GLADBACH, GERMANY.

IMPROVEMENT IN SPEED-RECORDERS.

Specification forming part of Letters Patent No. 205,844, dated July 9, 1878; application filed May 14, 1878.

To all whom it may concern:

Be it known that I, HEINRICH DORPMÜLLER, of Munich-Gladbach, Germany, have invented a new and useful Improvement in Speed-Indicators, of which the following is a specification:

The object of my invention is to provide an apparatus which shall graphically represent the number of revolutions of a rotating shaft or axle, registering as well the time required for the whole or any part of the revolutions.

The invention consists in a heart-shaped cam, receiving its motion from the rotating shaft or axle in such a manner that its number of revolutions shall be in a known direct ratio to the number of revolutions of the shaft or axle, the speed of which is to be graphically recorded, said cam imparting rectilinear reciprocating motion to a marker moving in guides, the extent of such rectilinear motion being likewise proportional to the number of revolutions, and graphically recorded by the marker on a paper dial, or on a strip of paper moved by clock-work, and containing divisions for the time and the number of revolutions; also, in a novel construction of inclosing-case for a speed-recorder or other delicate apparatus attached to or carried by a vehicle.

In the accompanying drawing, in which similar letters of reference indicate like parts, Figure 1 is a ground plan of the dial, marking-slide, and heart-shaped cam. Fig. 2 is a ground plan on a smaller scale, showing the means for transmitting motion to the cam-shaft and the position of the clock-work. Fig. 3 is an elevation of the operating parts. Fig. 4 shows the apparatus connected to a rotating shaft. Fig. 5 shows the apparatus connected to the rotating axle of a car.

A is the frame on which the entire apparatus is mounted. In the compartment B of this frame a clock-work of the usual construction is placed, of which, in the drawing, the arbor *b* only is shown, which projects above the top of the compartment. This arbor makes one revolution in three hours; but any other convenient speed may be selected.

To the upper end of the arbor *b* a circular disk, *c*, is attached, which shares the motion of the arbor. On the top surface of this disk a card or dial, *p*, is placed, which has printed

on it radii, for indicating time, and equidistant concentric circles. It is held in position by a spring, *z*, and nut M, or by other suitable means.

R is a pulley, the shaft of which turns in a bearing in the frame A, or in a bracket attached to the same. From the pulley R motion is transmitted to the shaft *i* by means of a forked coupling, *m*.

By means of a series of worms and worm-wheels on the shafts *i*, *i'*, *i''*, and *l*, or by any other equivalent means, the speed is reduced in such a manner that the vertical shaft *l* makes one revolution for every one thousand revolutions of the pulley R.

To the pulley R motion is imparted from a pulley, R', of the same diameter, but made in halves, and attached to the rotating shaft or axle the speed of which is to be recorded, as shown in Figs. 4 and 5.

The vertical shaft *l* projects above the frame and carries at its upper end a heart-shaped cam, *n*, Fig. 1 and Fig. 3, the outer surface of which is formed of two symmetrical curves, which act on a slide, O. This slide is placed in guides *v v*, and a spiral spring presses its right end against the cam, so that the slide is compelled to take a reciprocating rectilinear motion as the cam revolves.

To the opposite end of the slide O a marker, S, is fitted, which, during the reciprocating rectilinear motion, marks a line on the card *p*, which is revolved by clock-work.

The shape of the heart-shaped cam is such that for equal angular motion of its shaft the slide, with its marker, is moved equal distances—that is to say, it forms two symmetrical spirals, the radius vector of which increases or decreases as the angles. This is shown in Fig. 1, to the right, where the eccentricity is divided into five spaces by equidistant concentric circles, intersected by ten radii at equal angular distances of thirty-six degrees, the successive intersections of I II III IV V VI, of the radii *r* *r'* *r''* *r'''* *r''''* *r'''''*, and of the concentric circles *w* *w'* *w''* *w'''* *w''''* *w'''''* being connected by a curve. The distance between the outer and the inner concentric circle on the dial *p* is equal to the eccentricity of the cam, and the concentric circles are at equal distances apart, the distance in the drawing

being divided into five spaces. By this arrangement the marker will trace diagrams, in which, for equal numbers of revolutions, equal radial distances will be recorded. The curves on the dial will form a series of Vs, each complete V corresponding to a full revolution of the heart-shaped cam, or at the ratio represented in the drawing, to one thousand revolutions of the pulley R. The distance between two concentric circles on the dial indicates one hundred revolutions of R. The instrument thus graphically traces the number of revolutions made by a shaft and the time, showing all the irregularities of the motion, also backward motion.

In order that the time and recording mechanism may be protected from the jarring incident to the movement of the car or other vehicle, I attach to the outer surface of each side and end of the case A cushion-springs *a*, the outward branching arms of which bear against the inner surfaces of an outer fixed case, A', and the yielding of these springs takes up to a great extent the jarring, which would otherwise tend to disarrange the working parts of the apparatus.

If the instrument be attached to the axle of a car, as in Fig. 5, and if the circumference of the wheels be known, the distance traveled by the car is readily found. In practice, it will be convenient to run the car over a known

distance—say one mile; take the reading of the dial, and for any other indication divide the same by the reading for one mile to find the distance. In place of a circular rotating dial, a strip of paper may be used, which advances in a straight line by means of clock-work, and which has equidistant longitudinal lines, corresponding to the concentric circles of the circular dial, and equidistant lines at right angles to the strip, corresponding to the radii of the circular dial.

What I claim as my invention is—

1. The combination of the disk *c*, rotated by time mechanism, and having its paper face, or a part thereof, divided into concentric circles, the spring-slide *o*, carrying a marker at one end, the heart-shaped cam *n*, bearing edgewise against the other end of said slide, and having its two curves so proportioned that equal angular movements of said cam will force said slide longitudinally equal distances, substantially as and for the purpose set forth.

2. The combination, with the inner case A, provided on its outer surface with springs *a*, of the outer case A', inclosing said inner case, substantially as and for the purpose set forth.

HEINRICH DORPMÜLLER.

Witnesses:

CARL HAMMERSCHMIDT,
FERDINAND BRAATZ.