

J. E. FERGUSON.
 Railway Rail-Joint.

No. 205,848.

Patented July 9, 1878.

Fig. 1.

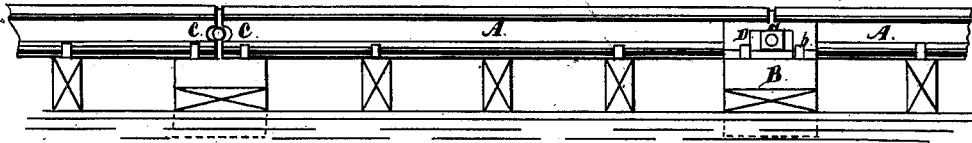

Fig 2.

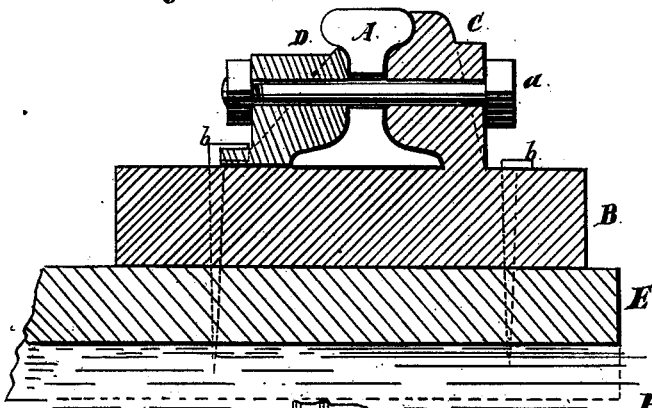
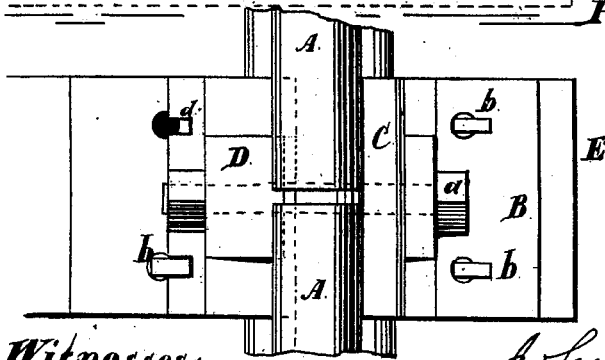

Fig. 3.



Inventor:

Witnesses:

*Henry Z. Barnes
 C. W. Bond*

*John C. Ferguson
 By Wm. H. Bond Atty.*

UNITED STATES PATENT OFFICE.

JOHN E. FERGUSON, OF CHICAGO, ILLINOIS.

IMPROVEMENT IN RAILWAY-RAIL JOINTS.

Specification forming part of Letters Patent No. **205,848**, dated July 9, 1878; application filed June 10, 1878.

To all whom it may concern:

Be it known that I, JOHN E. FERGUSON, of Chicago, Cook county, State of Illinois, have invented a new and useful Improvement in Railroad Chairs and Rails, of which the following is a full description, reference being had to the accompanying drawing, in which—

Figure 1 is a side elevation. Fig. 2 is a vertical cross-section, showing the bolt and end of a rail in elevation. Fig. 3 is a plan.

Railroad-rails in use are liable to wear at their ends more rapidly than at other points for well-known reasons. It is necessary to leave a small space between the rails to allow for expansion; but running trains have a tendency to move the rails in the direction of the moving train, crowding the rails against each other.

My invention consists in constructing a chair with a tram on one side permanently connected with the base of the chair, and extending up to the top of the rail to receive the tread of the wheels, and in so combining such chair with the rails that they cannot be forced out of place longitudinally by the action of the running trains.

In the drawings, A represents the rails. B is the base of the chair; C, the tram of the chair permanently connected with the base B, C and B forming a single piece. C extends up to the top of the rail, so as to receive the tread of the wheels. D is a separate splice-piece resting on the base B and fitting the neck of the rail, but not extending to its top. This splice-piece D is held in place by means of a bolt, *a*, which passes through the parts C D, but not directly through the rail.

The ends of the rails are provided with elongated recesses *e*, through which the bolt *a* passes.

The rails are to be laid with a little space between them as usual, to allow for expansion and contraction, and in consequence of the

described construction the rails will be free to expand and contract, and can have a limited longitudinal movement, such movement being limited by the bolts with which the ends of the rails will come in contact.

The chair is to be secured to the tie by means of suitable spikes *b*, which pass through holes in the base B. The edge of the part D should have notches or recesses to receive the spikes, as seen at *d* in Fig. 3, which shows one spike removed.

The rails are to be secured to a suitable number of ties, as usual; but the ties E at the ends of the rails should be large and well embedded in the ground.

The chair may be made of cast-iron. The part C, being fitted to all parts of the neck of the rail, and extending to the top, will support the rail by receiving the tread of the wheels at the joint, and will be efficient in preventing undue and rapid wear at that point. At the same time the rails will be free to expand and contract, as the bolts do not pass through them; but as the longitudinal movement of the rails will be limited by the bolts *a*, with which their ends come in contact, they cannot be forced from their proper positions by running trains.

In manufacturing the chair the parts B and C will be cast together.

What I claim as new is as follows:

A railroad-chair consisting of a base, B, tram C, permanently connected with the base and extending to the top of the rail, and splice-piece D, in combination with rails A, having elongated recesses *e* in their ends, and bolt *a* passing through said recesses, substantially as and for the purposes set forth.

JOHN E. FERGUSON.

Witnesses:

E. A. WEST,
H. F. BRUNS.