

J. KIRBY.
Bung-Lock.

No. 205,873.

Patented July 9, 1878.

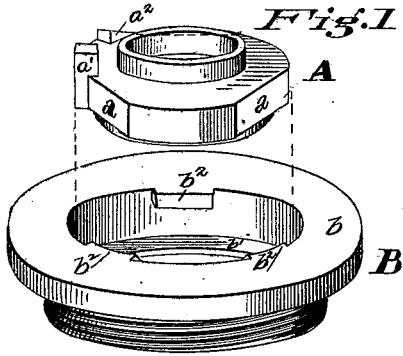

Fig. 2

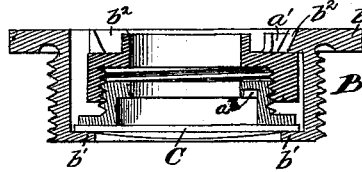

Fig. 4

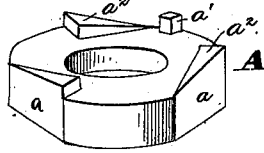

Fig. 3

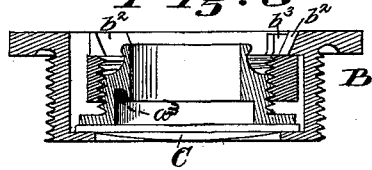

Fig. 5

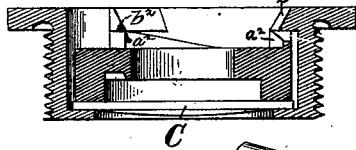
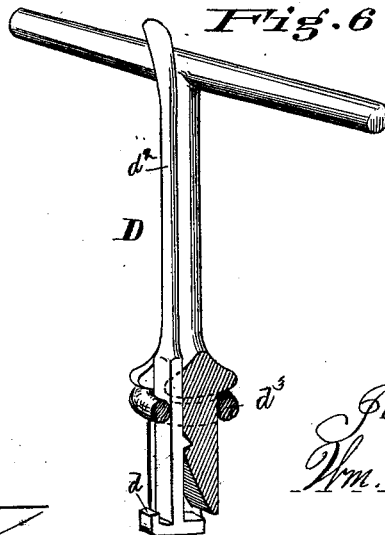

Fig. 6



Attest

Jas. W. Freckle.
Jas. A. Latten.

Inventor

Josiah Kirby per
Wm. Hubbell Fisher

Atty.

UNITED STATES PATENT OFFICE.

JOSIAH KIRBY, OF CINCINNATI, OHIO.

IMPROVEMENT IN BUNG-LOCKS.

Specification forming part of Letters Patent No. 205,873, dated July 9, 1878; application filed April 26, 1878.

To all whom it may concern:

Be it known that I, JOSIAH KIRBY, of the city of Cincinnati, county of Hamilton and State of Ohio, have invented certain new and useful Improvements in Bung-Locks, or devices for securing bungs in bung-holes, of which the following is a specification:

My invention has for its primary object, such a construction of the devices for retaining the bung in the bung-hole as that the security of the bung shall be absolute, excepting under the application of a suitable key, which will be in the possession of the proper parties.

The invention consists in such a novel construction of the followers as that by the engagement of the key with a portion of the underlying or concealed surface of the follower the above object shall be attained.

Among the other advantages derived from my invention are:

First, it enables me to employ a thin wafer-like bung. The advantages of such a bung over the old style of bungs are evident when it is understood that the devices employed by me to secure it are not more expensive than those extant and in use to protect the bung-stave when the common thick wooden bung is employed, these advantages being in substance economy in manufacture, owing to the saving in material, and, when made of wood, increased convenience in applying a ventilator by perforation.

Secondly, where, as will usually be the case, the key-hole in the follower is sizable and reaches the bung, the latter can be perforated, and a ventilator inserted through the follower and into the perforation of the bung.

Referring to the drawings, Figure 1 is a perspective view of the follower and its bushing. Fig. 2 is a sectional view of the same, showing the bung in position. Fig. 3 is a sectional view of a modified form of follower. Fig. 4 is a perspective view of still another form of follower. Fig. 5 is a sectional elevation of same; and Fig. 6 is a perspective view of one of the many and various forms of key which may be employed for removing the follower.

A is the follower, for securing the bung; and B is the bushing, which is secured in the

barrel, and forms the boundary of the bung-hole. The said bushing is intended to occupy not more space than the thickness of the barrel-stave supplies, except possibly what may be occupied by an extension-rim, *b*, and it is provided at its inner extremity with an interiorly-extending flange, *b'*, which serves as a seat to support the bung C, in order to enable the follower to force and keep the bung against the seat *b'*.

I provide the bushing B with inwardly-projecting lugs *b²*, and, as seen in Figs. 2 and 3, form the follower in two parts, having screw-threaded connection, so that it is in fact expansible, and enabled to extend itself between the said lugs and the bung until the latter is forced as firmly against the seat as desired.

In order to enable the lugs *b²* to retain the follower, the latter must be of greater diameter than the circular space lying exactly within the inmost extremities of the former; and in order to enable the follower to pass the lugs, it is formed with peripheral blanks *a*, and hence after insertion it must be partially revolved to remove the blanks from in line with the lugs in order that the latter may secure it. To prevent the turning of the follower too far, it is provided with an upright lug, *a¹*, to come in contact with one of the lugs *b²*; and in the case of the expansible follower (seen in Figs. 1, 2, and 3) I provide another lug, *a²*, so located upon the exterior portion of the follower as to, in conjunction with lug *a¹*, embrace the ends of one of the lugs *b²* when held there, and, causing the part to which it is secured to remain stationary, enable the rotation of the other part, so as to force the bung against seat *b'*, after which the only way of releasing the bung is to contract the follower by revolving the inner portion, and thus, disengaging the aforesaid lugs, enable the withdrawal of the follower from the bushing.

Now, as the inner portion of the follower cannot be turned by hand, the bung is substantially locked, and in order to enable the unlocking of it by the proper parties, as well as to lock it in the first place, I have formed in the under surface of a flange upon the said inner portion of the follower a depression, *a³*, to receive the projection of a suitably-formed key,

which may be brought in contact therewith through the central opening in the follower.

The key D, as seen in Fig. 6, is formed with a T-handle and provided with a pivoted or hinged projection, *d*, which, by means of its arm *d*², may be retired within the shank of the key to enable its insertion through the opening of the follower, and, by virtue of spring *d*³, be projected to engage with depression *a*³ of the follower. There are obviously many ways of forming the key and the obstruction for it to act upon in turning the lower portion of the follower; but the essential feature is the locating of the obstruction upon the under face of the projecting flange of the inner portion of the follower, which makes an inexpensive and reliable locking device.

The key D, aforementioned, although invented by me, does not constitute a part of the invention forming the subject of this specification and Letters Patent.

In the event of dispensing with the expansible characteristics of the follower shown in Figs. 1, 2, and 3, a suitable form of follower is shown in Figs. 4 and 5, where it will be seen that the follower is solid, and is provided with suitable inclined surface to act against the lugs *b*², so as to force the bung against the annular seat when the follower is rotated. This rotation is accomplished in the same manner as it is accomplished in the same followers shown in Figs. 1, 2, and 3—viz., by means of a key and a recess, *a*³, or equivalent obstruction, upon a portion of the concealed or underlying surface of the followers. It is also preferably provided with stop *a*¹.

If it is desired to apply a ventilator to the barrel, in order to enable the withdrawal of

the inclosed liquor, the ventilator is applied to the bung through the opening in the follower, when it may pierce the bung to gain the desired communication with the interior of the barrel.

It must be understood that the devices employed do not constitute a metallic bung, but are means of securing in place a relatively thin and wafer-like bung, so that it may, with the securing devices, come within the thickness of the barrel-stave, while it is essentially rigid and self-supporting against gaseous pressure from within.

Having thus described my invention, I claim—

1. In combination with a bung and its annular seat, the securing-follower A, arranged to be operated to release and secure the bung by means of the engagement of a key with an obstruction upon any portion of its underlying or concealed surface.

2. A bung-lock consisting of the bushing and the expansible follower, substantially as specified, the follower being in two parts, having a screw-threaded connection, the whole arranged to be operated to release and secure the bung by means of the engagement of a key upon any portion of its underlying or concealed surface.

3. In combination with a bung, an annular seat and a follower arranged to secure the bung up to the annular seat, and provided with an orifice through which a ventilator can be introduced to perforate the bung.

JOSIAH KIRBY.

Attest:

W. S. CHRISTOPHER,

C. WALTON, JR.