

L. G. KREGEL.
Wind-Engine.

No. 205,877.

Patented July 9, 1878.

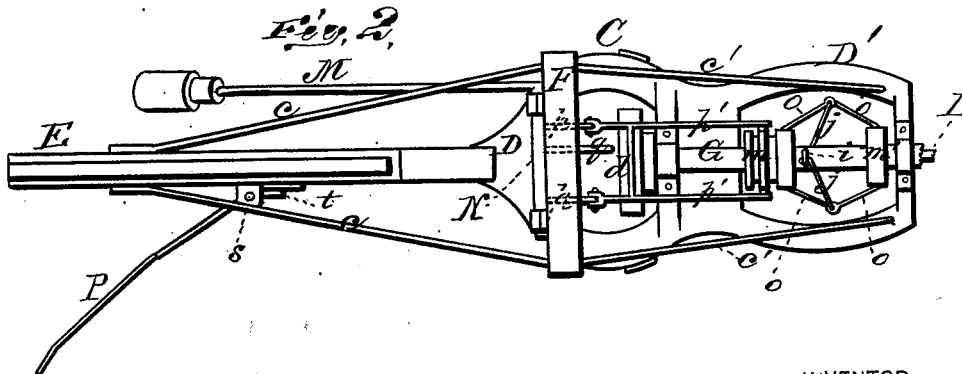
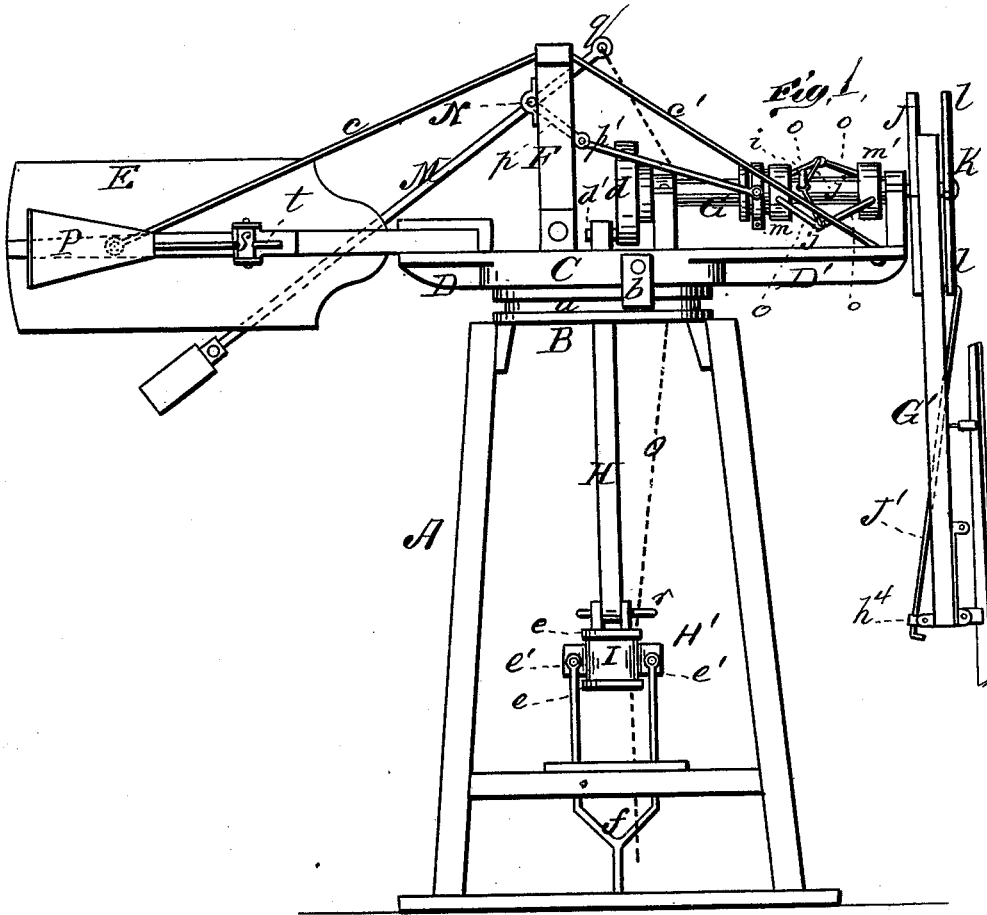

WITNESSES
J. J. Bates
F. J. Masi

INVENTOR
Louis G. Kregel.
by *E. W. Anderson.*
ATTORNEY

L. G. KREGEL.
Wind-Engine.

No. 205,877.

Patented July 9, 1878.

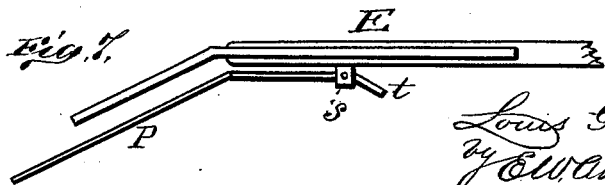
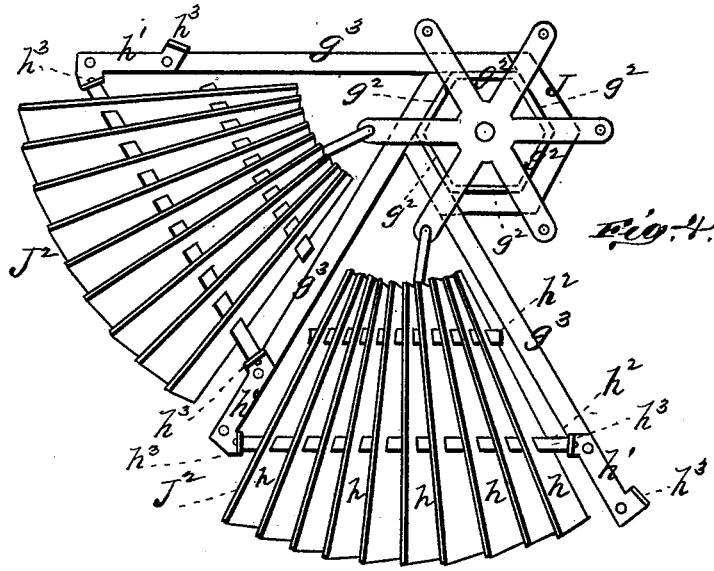
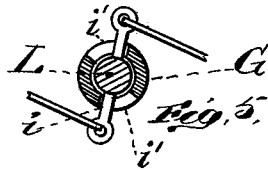
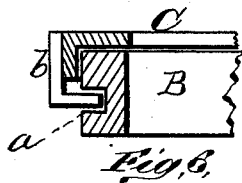
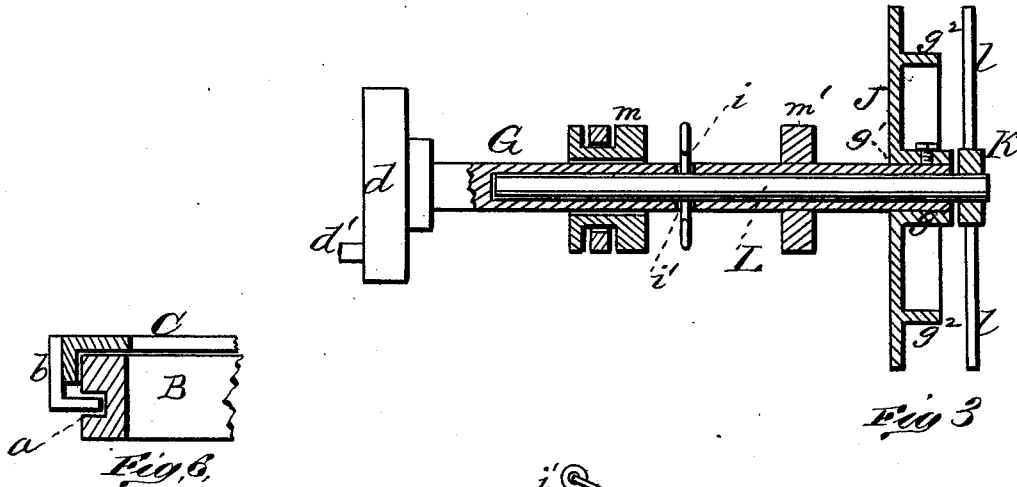

WITNESSES
E. J. Bates
J. J. Khasi

INVENTOR
Louis G. Kregel
 by *Edw. Anderson*
 ATTORNEY

UNITED STATES PATENT OFFICE.

LOUIS G. KREGEL, OF NEBRASKA CITY, NEBRASKA.

IMPROVEMENT IN WIND-ENGINES.

Specification forming part of Letters Patent No. 205,877, dated July 9, 1878; application filed March 9, 1878.

To all whom it may concern:

Be it known that I, LOUIS G. KREGEL, of Nebraska City, in the county of Otoe and State of Nebraska, have invented a new and valuable Improvement in Windmills; and I do hereby declare that the following is a full, clear, and exact description of the construction and operation of the same, reference being had to the annexed drawings, making a part of this specification, and to the letters and figures of reference marked thereon.

Figure 1 of the drawings is a representation of a side view of my invention. Fig. 2 is a top view thereof, and Figs. 3, 4, 5, 6, and 7 are detail views.

This invention has relation to improvements in windmills for actuating various descriptions of machinery.

The nature of the invention consists in certain novel combinations of parts, whereby very useful results are obtained, as will be hereinafter more fully explained.

In the annexed drawings, the letter A designates the tower of my mill, having at its upper end a smooth bed-plate, B, upon which the table C revolves horizontally. The bed-plate is circular in form, and has an annular groove, *a*, in its perimeter, with which plates *b*, rigidly secured to the turn-table C, are engaged, thereby holding it on the bed and allowing it to revolve thereon. The turn-table has two oppositely-projecting horizontal offsets, D D', to the first of which is rigidly secured a large vane, E, that is prevented from sagging by means of the brace-rods *c*, secured at one end to the vane-shaft and at the other to an upright frame, F, upon the table. The offset D', is braced to the said frame by the rods *c'*, and affords bearings to the tubular shaft G of the wind-wheel G'. This shaft has upon its inner end a wheel, *d*, having a wrist-pin, *d'*, to which is secured in the usual manner a pitman, H, pivoted by means of a bolt to a coupling device, H'. This is composed of a cylinder having at its upper and lower ends a flange, *e*, in the space between which is placed a metallic annulus, I, having lugs *e'* diametrically opposite each other, to which are secured in any suitable manner the ends of the branches of a forked connecting-rod or piston, *f*. By

this means the table may turn without in any manner affecting the said piston, for the reason that the cylinder rotates in the ring. This latter is made in two semi-annular sections bolted together around the cylinder, edge flanges *e* being made on the sections for this purpose.

The hub of the wheel consists of an equilateral hexagonal plate, J, provided with a box, *g*¹, by means of which it is passed upon and secured to the shaft G, and having upon its outer faces the hexagonal flange *g*², to the faces of which the arms *g*³, supporting the wind-sails J², are rigidly secured.

The wind-sails are of the general shape of a triangle, and are composed of tapering inclined slats *h* let into the spaced transverse cross-bars *h*², the outermost of which is provided with end plates, into which are screwed the spindles upon which the said sails revolve.

The arms *g*³ are each provided with a bearing-plate, *h*¹, having at each end, upon opposite sides thereof, a bearing, *h*³, in which the spindles aforesaid are journaled. The cross-bar *h*² has at its middle portion a furcated lug, *h*⁴, pivotally connected to a spoke, *l*, of a wheel, K, by means of a rigid rod, J¹.

The wheel K is rigidly secured upon the projecting end of a rod, L, that extends through the bore of the tubular shaft G, and is prevented from endwise displacement relative thereto by means of a pin, *i*, extending through registering-slots *i'* in the said shaft G and a perforation in the rod L. The rod L has thus a degree of rotary motion allowed it.

m m' designate, respectively, a movable and a fixed collar upon the shaft G, that are connected by the toggle-jointed rods *o* upon their opposite sides. The plane of these rods is at right angles to the length of the pin *i*, and their joints are connected with the projecting ends of the pin *i* by means of the rigid rods *j*.

When the movable collar is thrust toward the fixed one, the distance between the main shaft and the joints of said rods *o* is increased, a rotary motion imparted to the rod L through the rods *j*, and the wind-sails drawn up with their flat surfaces in the wind through the medium of the spoke-wheel K and connecting-rods J¹.

The movable collar is connected to a rock-shaft, N, having its bearings in the uprights F, and provided with a weighted arm, M, by means of the spaced suitably-braced jointed rods $p p'$.

The weighted arm M holds the sections of the wheel into the wind; but they may be readily swung down out of it by drawing down forcibly upon a rope, rod, or chain, O. This pull is secured to an arm, q , of the rock-shaft, extends downward through a guide-eye, r , upon the cylinder, and is carried through the heads of the cylinder. By this means the pull is prevented from being twisted by the rotations of the turn-table as it is carried around by the cylinder aforesaid.

The weather-vane is provided with a subsidiary fan or vane, P, extending along its sides, and having free horizontal vibration upon a hinge, s , by means of which it is connected thereto. The subsidiary vane is provided with a projecting arm, t , in front of said hinge, forming an obtuse angle with the longitudinal axis, and being in the same horizontal plane with the said axis of the vane. When a thunder-gust comes on from the rear the wind forces its way in between the main and subsidiary vane, and, being confined, compels the latter to swing outward from the former vane as far as its projecting arm t will permit—that is, at an acute angle to the main vane—thus overbalancing the main vane and causing the wheel to turn with its edge more or less to the wind. By this means the wind acts so forcibly in the space between the main and subsidiary vane that it readily overcomes the stiffness of the hinge s , caused by the rusting thereof or its being clogged by dust. A vane hinged to the end of the main vane would not possess this quality, and would therefore be much less sensitive. Should its force be very great, the sections of the wheel will swing out, allowing

the wind free passage by overbalancing the weighted arm aforesaid.

In practice, the main vane may be sometimes bent at its free end parallel to the subsidiary vane, as shown in Fig. 7.

What I claim as new, and desire to secure by Letters Patent, is—

1. The wind-wheel consisting of the hub-plate J, having the box g^1 and the hexagonal flange g^2 , the arms g^3 , secured to the faces of the said flange, and the wind-sails J^2 , journaled in the said arms, substantially as set forth.

2. The combination, with a wind-wheel having the vibratory wind-sails J^2 and the tubular shaft G, with a movable collar, m , and a fixed collar, m' , of the toggle-jointed rods o , connecting the said collars, the rotatory rod L, the pin i , the connecting-rods j , the spoke-wheel K, and the rods J^1 , substantially as specified.

3. The combination, with the tubular shaft G, having transverse slots i' and the movable and fixed collars $m m'$, of the shaft L in the shaft G, the pin i , the toggle-jointed rods o , the connecting-rods j , and a sliding mechanism for the said movable collar, substantially as specified.

4. The combination, with the tubular shaft G and the inside rotary shaft L, of a fixed and a movable collar on the former, toggle-jointed rods connecting said collars, rods connecting the shaft L and the rods o , the jointed rods $p p'$, the rock-shaft N, and weighted arm m , substantially as specified.

In testimony that I claim the above I have hereunto subscribed my name in the presence of two witnesses.

LOUIS G. KREGEL.

Witnesses:

HENRY KREGEL,
HERMAN H. PETRING.