

W. H. MORRISON.
King-Bolts.

No. 205,891.

Patented July 9, 1878.

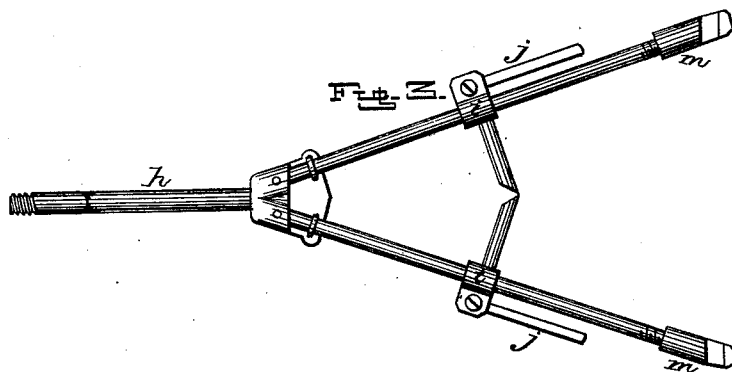
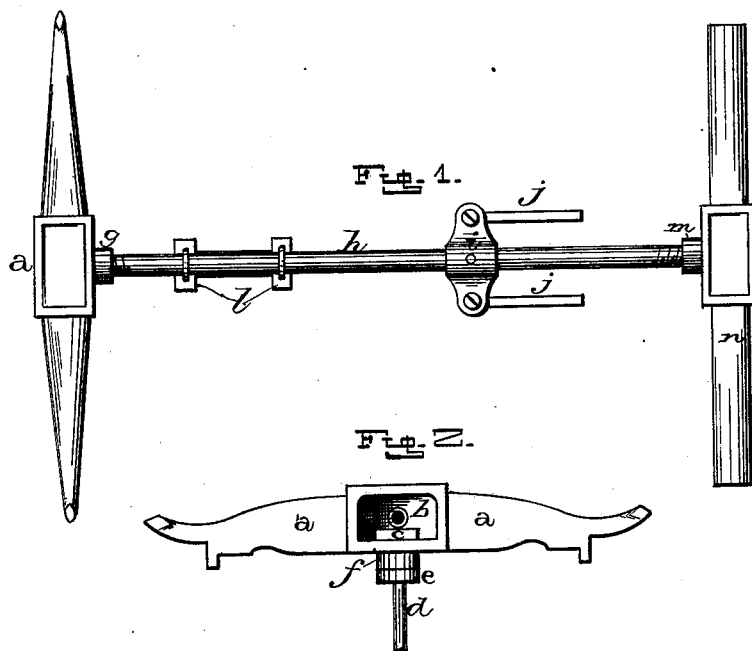

Witnesses:

J. W. Garner
W. S. D. Haines

Inventor:

W. H. Morrison.
per
F. A. Lehmann,
att'y.

UNITED STATES PATENT OFFICE.

WILLIAM H. MORRISON, OF CANNING, ONTARIO, CANADA.

IMPROVEMENT IN KING-BOLTS.

Specification forming part of Letters Patent No. **205,891**, dated July 9, 1878; application filed June 6, 1878.

To all whom it may concern:

Be it known that I, WILLIAM HENRY MORRISON, of Canning, in the county of Oxford and Province of Ontario, Canada, have invented certain new and useful Improvements in Running-Gear; and I do hereby declare the following to be a full, clear, and exact description of the invention, such as will enable others skilled in the art to which it pertains to make and use it, reference being had to the accompanying drawings, which form part of this specification.

My invention relates to an improvement in running-gear for vehicles; and it consists in the peculiar construction of parts, whereby the gear is made both lighter and cheaper, and can be more readily taken apart, as will be more fully described hereinafter.

The accompanying drawings represent my invention.

a represents the head-block, which is made of malleable iron, in one piece, and of any shape and size desired. Through the front edge of this block is made a suitably-shaped opening, *b*, which extends back nearly through the block, and which is of sufficient size to readily accommodate the nut *c* and give free access to it at all times. Passing up through the block *a* into this opening *b* is the king-bolt *d*, upon the top of which the nut *c* screws. This bolt *d* has a circular flange, *e*, formed upon it, which bears up against the under side of the projection *f* on the block. By tightening the nut *c* the bolt can be clamped rigidly in position, and yet can be loosened and removed at any moment without interfering in any way with any other part of the gearing.

This construction of parts is very simple, cheap, and a great convenience.

Screwed into the screw-socket *g*, on the rear side of the block, is the reach *h*, which is made of gas or other suitable pipe, so as to combine both lightness and strength. Screwed to this reach, or otherwise held in position, is the clip *i*, the screws of which not only hold the two halves of the clip in position, but the braces *j* also. At any suitable distance in the rear of the head-block is the circle-keep *l*, which is made of malleable cast-iron, and is clamped to the under side of the reach by any suitable devices. The rear end of the reach screws into the connection *m*, which passes down over the top of the rear axle *n*.

Where a double reach is necessary, it will be composed of two pieces of pipe instead of one, and all of the fittings connected thereto will be made of malleable cast-iron.

Having thus described my invention, I claim—

The bolt *d*, having flange *e* and clamping-nut *c*, in combination with the metallic head-block *a*, provided with recess *b*, open from the front, so that access may be had to the nut at all times, substantially as shown.

In testimony that I claim the foregoing I have hereunto set my hand and seal this 29th day of May, 1878.

WILLIAM HENRY MORRISON. [L. S.]

Witnesses:

JONATHAN KITCHEN,
ROBERT J. TURNER.