

G. SANFORD.  
Fiber Machines.

No. 205,91f.

Patented July 9, 1878.

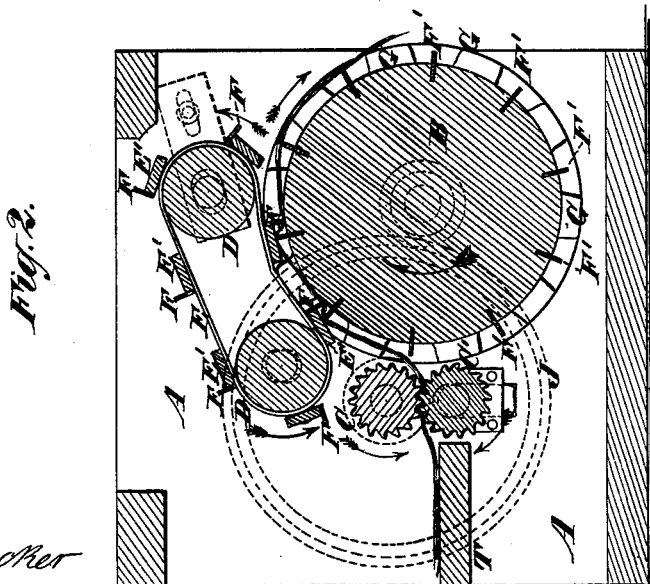
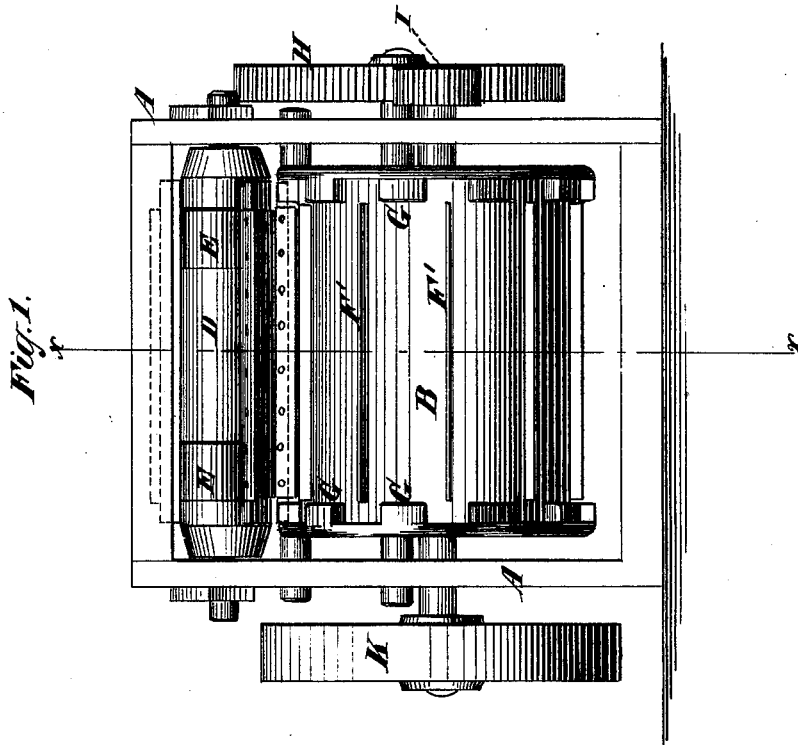

Witnesses  
*John Becker*  
*Geo. Haynes*

Inventor  
*Geleton Sanford*  
*By his Attorneys*  
*Brown & Allen*

# UNITED STATES PATENT OFFICE.

GELSTON SANFORD, OF BROOKLYN, ASSIGNOR TO MALLORY & SANFORD AMERICAN AND FOREIGN FLAX AND HEMP DRESSING MACHINE COMPANY, OF NEW YORK, N. Y.

## IMPROVEMENT IN FIBER-MACHINES.

Specification forming part of Letters Patent No. 205,911, dated July 9, 1878; application filed May 14, 1878.

### *To all whom it may concern:*

Be it known that I, GELSTON SANFORD, of the city of Brooklyn, in the county of Kings and State of New York, have invented an Improvement in Machines for Separating Fiber from the Stalks and Leaves of Fiber-Producing Plants; and I do hereby declare that the following is a full, clear, and exact description of the same, reference being had to the accompanying drawing, forming a part of this specification.

My invention is an improvement on a machine Letters Patent for which were granted to me June 24, 1862, said Letters Patent being numbered 35,708.

My present invention has for its object the removal of some of the defects inherent in the said machine and the carrying out of some new features that have been suggested by experience.

The invention consists in the combination of a cylinder carrying scrapers, a belt or belts, also carrying scrapers, and bars or lags of wood or other material that will not injure the edges of the said scrapers, said lags of wood or other material being attached to the said belt or belts, and arranged to present their faces to the edges of the scrapers carried by the said cylinder, as more fully hereinafter set forth.

Figure 1 in the drawing represents a machine constructed in accordance with my present invention, that side of the machine from which the material is delivered after being operated upon being presented to the front. Fig. 2 is a section made on the line *x x* in Fig. 1.

A is the frame of the machine, supporting bearings for the shafts for a cylinder, B, fluted feed-rolls C C', and pulleys or rollers D D, the said shafts being arranged in parallel relation with each other in the said frame. The said frame also supports a feed-table, T, placed in relation with the said feed-rolls C C', as shown in Fig. 1, and hereinafter described.

Upon the pulleys or rollers D D are arranged a belt or belts, E E. The said belts E E are connected and held in parallel relation with each other by bars or lags of wood

or other material that will not injure the edges of scrapers hereinafter described; or the said bars may be made of metal, and clothed with rawhide or other material which will not injure the said edges of said scrapers.

To one margin of each of the said bars is attached a scraper, F, which acts in conjunction with other scrapers, F', arranged at uniform intervals around, and inserted in or attached to, the cylinder B, and projecting radially therefrom in such manner that their edges lie in parallel relation with the shaft of the said cylinder B.

Arranged centrally between the said scrapers F', and projecting from or attached to the said cylinder, are teeth G, preferably placed at each end of the said cylinder, as shown in Fig. 1. The said teeth are of such width and pitch that they engage the said bars F between them, and actuate the belts in a manner analogous to that of an endless chain and rag-wheel movement. In other words, the rotation of the cylinder B causes the belts E E to rotate, as indicated by the arrows in Fig. 2.

The said cylinder B is made of wood or other material that will not blunt or injure the edges of the scrapers carried by the said belts.

The upper feed-roll is driven by a pinion, H, which meshes into a gear, I, on the shaft of the cylinder B. The flutes of the said feed-roll intermesh with the flutes of the lower feed-roll, and cause the same to turn when the upper feed-roll is turned. The lower of the said feed-rolls is the pressure-roll, or that to which pressure is applied to cause the said rolls to firmly engage the material to be operated upon, as hereinafter specified.

By making the lower of the said feed-rolls the pressure-roll, I am enabled, while placing the belts E E above the cylinder B, to bring the said feed-rolls so close to the cylinder B that the entire length of the material to be treated, when fed in between the said rollers, will be subjected to the action of the scrapers, except a very small portion at the butts, which is of little or no value.

The pinion I on the shaft of the cylinder B is considerably smaller than the gear on the upper feed-roll C; and the result is that,

as the circumference of the said cylinder is much larger than the circumference of the said feed-roll, the circumferential velocity of the feed-rolls will be very much less than that of the said cylinder and the belts E E, the latter of which move at the same velocity as the perimeter of the said cylinder, being driven by the teeth G on the said periphery.

The rotation of the said cylinder is effected by power applied to the shaft of the said cylinder through the pulley K or any other suitable transmitter of motion. This causes the simultaneous rotation of the feed-rolls and of the belts E E, and successively presents the scraping-edges of the scrapers F to the periphery of the cylinder midway between the scrapers F', which project from the said periphery. At the same time the scrapers F' are successively presented to the surfaces of the bars or lags E' about midway of the width of said bars.

The material from which the fiber is to be separated is shown at *m*, Fig. 2. It is operated upon by the machine as follows: The machine being driven, as hereinbefore described, and as indicated by the arrows, the stalks or leaves of the plant from which the fiber is to be separated are arranged as nearly parallel to each other as is convenient and

practicable, and fed in from the feed-table T between the feed-rolls C C', as shown in Fig. 1.

As the material is fed in by the feed-rolls at a much slower rate than the scrapers F F' move, the said material is scraped between the said scrapers and the surfaces to which the edges of the said scrapers are presented, and the woody and refuse portions of the same are removed, while the fiber, freed from the said refuse portions, is retained. After the said fiber has been retained long enough to free it thoroughly from the refuse matters, it is released, and then passes out of that side of the machine opposite the feed-rolls.

I claim—

The combination of the cylinder B, carrying scrapers F', feed-rolls C C', belt or belts E, carrying scrapers F', and bars or lags E', made of wood or other material that will not injure the edges of scrapers, said lags being attached to the belt or belts E, and arranged to present their outer faces to the edges of the scrapers F', substantially as and for the purpose set forth.

GELSTON SANFORD.

Witnesses:

T. J. KEANE,  
ALFRED BURHORN.