

T. H. SHAHAN.
Candlestick.

No. 205,915.

Patented July 9, 1878.

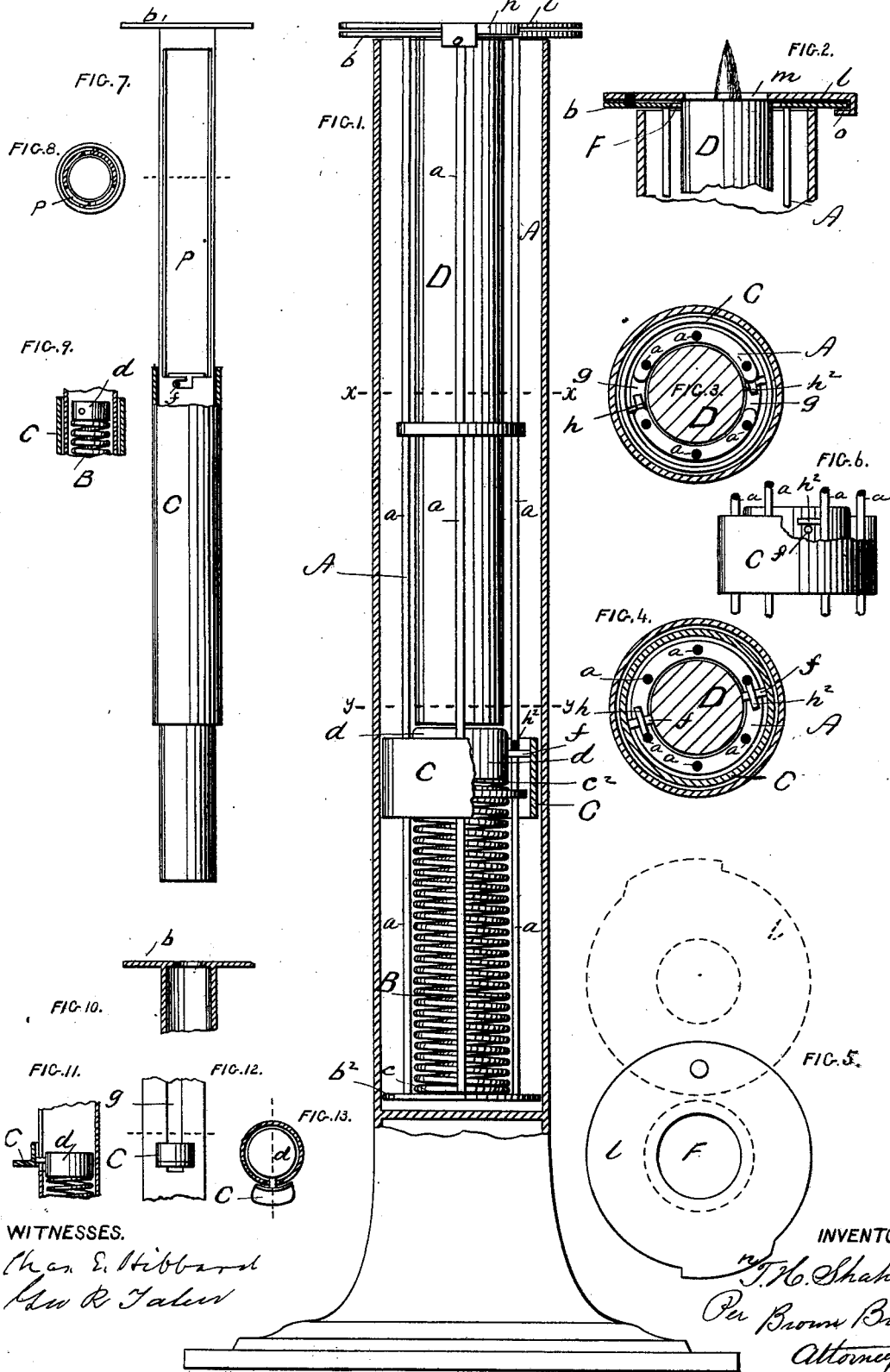

WITNESSES.
Chas. E. Hibbard
Adm R. Talbot

INVENTOR.
T. H. Shahan
Per Brown Bros
Attorneys.

UNITED STATES PATENT OFFICE.

THOMAS H. SHAHAN, OF BOSTON, MASSACHUSETTS.

IMPROVEMENT IN CANDLESTICKS.

Specification forming part of Letters Patent No. 205,915, dated July 9, 1878; application filed June 28, 1878.

To all whom it may concern:

Be it known that I, THOMAS H. SHAHAN, of Boston, in the county of Suffolk and State of Massachusetts, have invented certain new and useful Improvements in Candlesticks, of which the following is a specification:

This invention relates to candlesticks adapted for the automatic feed of the candle to the burning end of the candle-stick as the candle from time to time is consumed.

The invention in main consists in the construction of the stick and of the spring or feed device to the candle for a compression of the spring independent of the insertion of the candle, and in such manner that the compression of the spring can be held while the candle is being inserted and adjusted in its proper position in the candlestick.

Also, in combination with the above, the invention consists in the construction of the stick and spring for the two to be interlocked when the spring is compressed to hold the spring against action except when such interlock is released.

In the accompanying plate of drawings, Figure 1 is substantially a view in elevation of my improved candlestick; Fig. 2, a central vertical section in detail at the burning end of the candlestick; Figs. 3 and 4, cross-sections on lines *x x* and *y y*, respectively, of Fig. 1; Fig. 5, a plan view; Fig. 6, an elevation in detail; Figs. 7, 8, 9, 10, 11, 12, and 13, views illustrative of modifications in construction of the candlestick shown in the preceding figures, which will be hereinafter fully explained.

In the drawings, A represents a skeleton casing, made of parallel wires *a*, at each end secured to parallel head-plates *b* and *b*², to the lower one, *b*², of which is secured one end, *e*, of a spiral spring, B, which lies within the casing, and when not compressed substantially fills the casing from end to end. The end *e*² of the spring B carries a head, *d*, and a horizontal cross-bar, *f*, which passes between two diametrical open spaces, *g*, of the skeleton frame A to the outside thereof, where it terminates in a handle, C, shown as a sleeve which loosely surrounds the outside of the skeleton frame, except in Figs. 11, 12, and 13, wherein it is shown as a thumb-piece; *h h*², two shoulders on the skeleton frame A, and

thereon so located that the projecting ends of the cross-bar *f* to the spring B can be set under them when such cross-bar is brought below and then turned under them, whereby the spring can be interlocked with the skeleton frame, which obviously prevents its movement in the casing A in a direction against such shoulders *h h*².

The shoulder construction of the casing A and the construction of the spring B to be interlocked therewith obviously, under a proper location of the shoulders *h h*² relative to the length of the casing A, enables the spring B when compressed to be held against reaction.

The compression of the spring is secured by sliding the sleeve C down the outside of the casing A, and the spring is held under such compression by setting its cross-piece *f* under the shoulders *h h*² of the casing A, which shoulders are suitably located therefor.

With the spring B thus compressed and held the candle D is placed in the casing A through the central opening F in the head *b*, and brought to rest on the spring B, after which the lid-plate *l*, pivoted to the top of the head-plate *b*, is swung over the opening F of such head-plate *b*, and its central opening *m* is brought over the top of the candle D. The tip end of the candle D rests against the under side, and its wick is exposed at the opening *m* of the lid *l*, and in this position the candle is held while being burned under the pressure of the spring B when released from its interlock with the casing A.

The closing swing of the lid *l* over the head-plate is limited by the abutment of its rim or flange *n* against the edge of the head-plate *b*, and it is held against the upward pressure of the candle not only by being pivoted, as described, but also by the piece *o* of the lid, which projects under the head-plate *b*.

The construction of the candlestick shown in Figs. 7, 8, 9, and 10 is substantially similar to that particularly above described and shown in the preceding figures as to the compression of the spring and the locking of it against reaction, and differs therefrom in the adaptation of the casing A for the insertion of the candle D at one of its sides by constructing it with an opening, *p*, of suitable size therefor; also, in an extended sleeve, C, of suitable length to

cover said opening *p* as the spring and candle rise from the consumption of the candle, and to hold the spring from bulging or projecting through it, and also in dispensing with the swinging lid *l*; but the construction of candlestick particularly described is most preferable.

It is intended that either candlestick herein described is to be suitably cased—as, for instance, as shown in Fig. 1; but obviously such a casing is not essential either to the operation or use of the candlestick herein described.

The sleeve *C* makes a handle to the spring *B*, and as it is attached to the spring relatively to the candle case or holder *A*, as described—that is, so as to be without the casing—and as the casing is formed as described, which permits the connecting part between the spring *B* and sleeve *C* to move along the length of the candlestick, obviously the spring can be first compressed of itself and independently of the insertion of the candle, and then the candle inserted.

I am aware that a candlestick has been provided with a spring impelled plunger having a shank projecting through the lower end of the tube composing the candlestick, said shank being intended to be grasped by the hand for drawing down or depressing the plunger; but such is not my invention, and is hereby disclaimed.

Having thus described my invention, what I claim, and desire to secure by Letters Patent, is—

1. The combination, with the frame or casing *A* and spiral or other suitable spring of a candlestick, of a sleeve connected with the upper end of said spring, and arranged to slide on the exterior of the frame or casing, substantially as and for the purpose described.

2. In a candlestick, the combination and arrangement of a spiral or other suitable spring for being compressed and secured against reaction, substantially as and for the purpose described.

3. The swinging lid *l*, having opening *m*, in combination with the candlestick-casing *A*, having a spiral or other suitable spring, *B*, substantially as described, for the purpose specified.

4. The swinging lid *l*, having opening *m* and flange *n*, in combination with a candlestick having a spiral or other suitable spring, *B*, substantially as described, for the purpose specified.

5. The swinging lid *l*, having opening *m*, flange *n*, and under-projecting lip *o*, in combination with a candlestick having a spiral or other suitable spring, *B*, substantially as described, for the purpose specified.

THOS. H. SHAHAN.

Witnesses:

EDWIN W. BROWN,

GEO. H. EARL.