

F. J. UNDERWOOD.
Railroad Track-Drill.

No. 205,927.

Patented July 9, 1878.

FIG. 1.

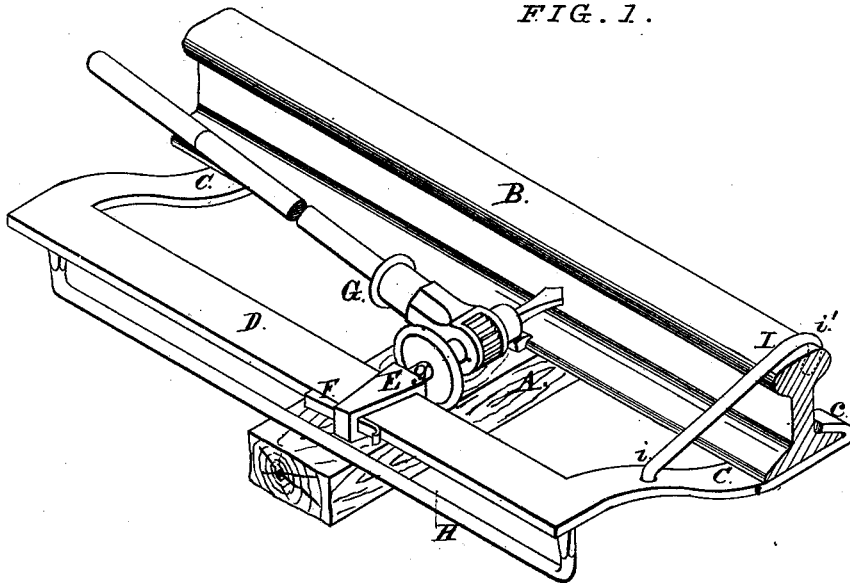
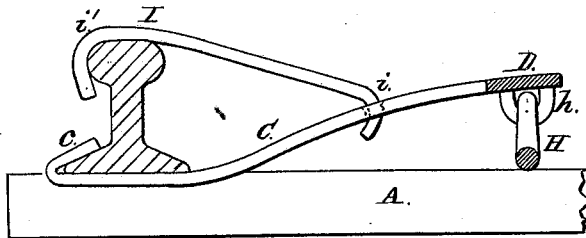

FIG. 2.



ATTEST:
Geo. H. Knight,
Walter Allen

INVENTOR:
Flavie J. Underwood
By Knight, Bro.
Atty.

UNITED STATES PATENT OFFICE.

FLAVIUS J. UNDERWOOD, OF NORTH SPRINGFIELD, ASSIGNOR OF TWO-THIRDS HIS RIGHT TO ANDREW WARREN AND PERRIN G. MARCH, OF ST. LOUIS, MISSOURI.

IMPROVEMENT IN RAILROAD-TRACK DRILLS.

Specification forming part of Letters Patent No. 205,927, dated July 9, 1878; application filed April 20, 1878.

To all whom it may concern:

Be it known that I, FLAVIUS J. UNDERWOOD, of North Springfield, Greene county, State of Missouri, have invented certain new and useful Improvements on Railway-Track Drills, of which the following is a full, clear, and exact description, reference being had to the accompanying drawings, making part of this specification.

My improvement relates to a device for the support of the ratchet-drill in boring transverse holes through the web of the rail when it is in position in the track; and my improvement consists in the described combination of parts going to form such device, and particularly to a pivoted foot or bail, which rests on one or more ties, and serves to support one side of the frame, and to clamp it fast to the rail by gripping the hooks of the frame upon the base of the rail.

The improvement also consists in an adjustable center-block, countersunk to receive the heel-center of the feed-screw of the ratchet-drill, said block being mortised for the passage of the slide-bar of the frame, and fixed to said bar, when in use, by a wedge-key, set-screw, or equivalent device.

In the drawings, Figure 1 is a perspective view of my improvement. Fig. 2 is a transverse section.

A is a tie. B is the rail. C C are two clamp-arms projecting at right angles from the ends of the bar D. The ends of the arms C are turned up into hooks *c*, which engage the outer edge of the rail base.

E is the center-block, which is adjustable endwise upon the bar D, so as to bring it opposite to the part of the rail in which the hole is to be drilled. This block is mortised for the passage of the bar D, and is made to be easily moved on the bar when the wedge-key F is loose, but is held rigidly to the bar when the key is driven in tight, as shown in the drawings. The block E has a countersink or

center-hole to receive center *g* of the ratchet-drill G. In place of a wedge, F, I may use a set-screw or other equivalent fastening.

The bar D is parallel with the rail B, and it is held on the same level as the hole to be drilled, by a bail or bar, H, which rests on the tie A, and is preferably connected to the bar D at each end by joints *h*, so as to allow the bail to be forced into a vertical position beneath the bar D to clamp the frame in place, or to be turned inward or outward to release the gripe of the hooks *c* upon the rail and allow the instrument to be moved from place to place. When the instrument is in the position shown, the hooks *c* tightly gripe the rail.

I claim no novelty in any part of the ratchet-drill proper, G, and need not describe the same.

I is a dog, which is bent into a hook at each end, the hook *i* engaging in a hole in the frame, and the hook *i'* engaging over the top of the rail, so as to hold the rail firmly to the drill in cases when the rail may be loose upon the tie. When the rail is fast to the tie the dog I is not needed, and may be disconnected from the frame by lifting the hook *i* from the hole in the frame. In this case there is nothing in the instrument to prevent a train from passing over the track.

I claim as new and of my invention—

1. The combination of bar D, connected at its ends with the rail by arms C, and carrying an adjustable center-block, E, with center-hole *e* to receive the center *g* of the ratchet-drill, and locked in position by a key, F, or equivalent locking device, as set forth.

2. The clamping and supporting bail H, in combination with the frame D C C, for the purpose set forth.

FLAVIUS J. UNDERWOOD.

In presence of—
SAML. KNIGHT,
GEO. H. KNIGHT.