

H. C. WEY.  
Measuring Device for Shot Canisters.

No. 205,934.

FIG. Patented July 9, 1878.

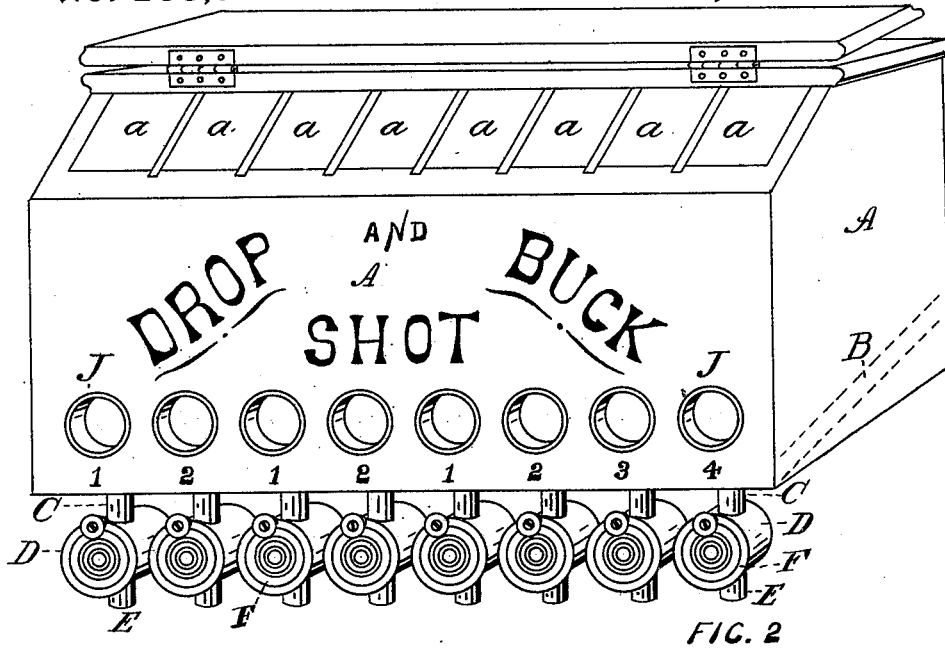
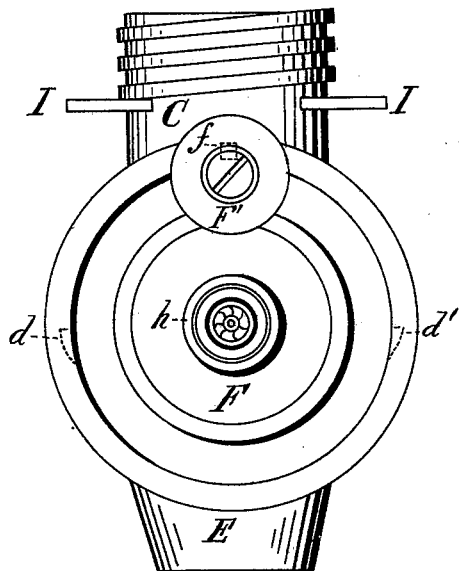
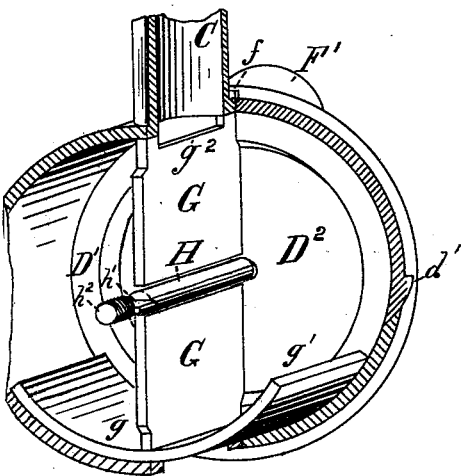

FIG. 2

FIG. 3



ATTEST  
Geo. H. Wright.  
Walter Allen

INVENTOR  
Herman C. Wey  
By Wright & Allen  
Atty.

H. C. WEY.  
Measuring Device for Shot Canisters.

No. 205,934.

Patented July 9, 1878.

FIG. 4

A.

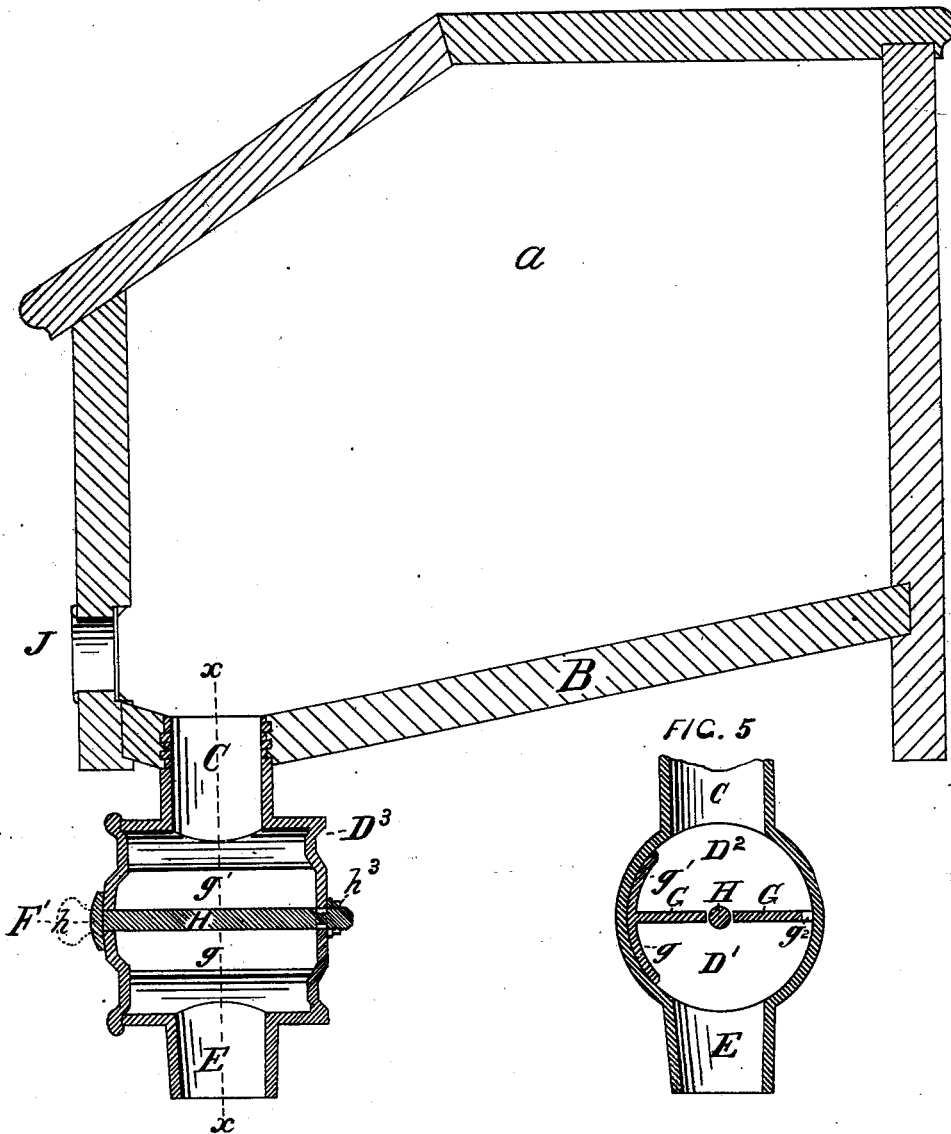

ATTEST,  
Geo. H. Knight,  
Walter Allen

INVENTOR,  
Herman C. Wey  
Geo. H. Knight Atty.

# UNITED STATES PATENT OFFICE.

HERMAN C. WEY, OF HIAWATHA, KANSAS.

## IMPROVEMENT IN MEASURING DEVICES FOR SHOT-CANISTERS.

Specification forming part of Letters Patent No. 205,934, dated July 9, 1878; application filed April 24, 1878.

*To all whom it may concern:*

Be it known that I, HERMAN C. WEY, of Hiawatha, Brown county, Kansas, have invented a certain new and useful Improvement in Canisters for Shot, &c., of which the following is a full, clear, and exact description, reference being had to the accompanying drawings, forming a part of this specification.

This is an improvement on the patent (No. 162,326) granted to me April 20, 1875.

This above invention included a canister or box with a number of compartments for different articles or different sizes or descriptions of the same article, with a valve at the bottom of each compartment to allow any part of the contents to run out.

My present improvement consists in the combination, with a canister divided into compartments for containing shot or other solid articles that will run in a stream, of a measuring-valve, arranged at the lower front part of the canister, to measure the contents as they are withdrawn, and thus dispense with the necessity of using scales to weigh the articles.

In the drawings, Figure 1 is a perspective view of the canister. Fig. 2 is a front view of the valve. Fig. 3 is a rear perspective view of the valve with part of the case broken away. Fig. 4 is a transverse section. Fig. 5 is a section of the measuring-valve at *x x*, Fig. 4.

The canister *A* may consist of a number of compartments, *a*, to contain different sizes of shot or different articles. It should have an inclined bottom, (shown in dotted lines at *B*), to convey the contents to the front over the valve-pipe *C*. The pipe *C* forms communication between the compartments *a* and a horizontal barrel, *D*, in which the valve cut-off oscillates in measuring the shot or other article. The article escapes from the measuring-valve through a nozzle, *E*.

The cylindrical barrel *D* is closed at the rear end *D*<sup>3</sup>, and is stopped at the front end by the circular face-plate *F*, to which is attached the valve-plate *G*, which extends diametrically across the interior of the barrel *D*, and extends from end to end of the same, so as to divide the barrel into two equal compartments, *D*<sup>1</sup> *D*<sup>2</sup>. The plate *G* is slotted through axially, for the passage of the bolt *H*, upon which it turns, and by which the parts are held to-

gether. This bolt *H* has a head, *h*, outside the face-plate *F*, and passes through the rear end of the barrel *D*, where it receives a nut, *h*<sup>2</sup>, to hold it in. Where it passes through the back plate of the barrel it has a spline, *h*<sup>1</sup>, which enters a recess of the end plate, to keep the bolt from turning, and thus to prevent the unscrewing of the nut *h*<sup>3</sup> upon the screw-threaded end *h*<sup>2</sup>.

At the lower edge of the plate *G* is attached a segmental cut-off plate, *g g*<sup>1</sup>, which is concentric with the barrel and fits its inside circumference. By the turning of the plate *G* the cut-off may be placed in position to either open or close the nozzle *E* by means of either of its wings *g* or *g*<sup>1</sup>. When the plate *G* is in the position shown in Fig. 3 the contents of the compartment *a* will run down and fill both of the compartments *D*<sup>1</sup> and *D*<sup>2</sup>. Then, if the plate is turned to bring the stop-lug *f* to the stop-lug *d*, the cut-off wing *g* will be moved from the upper end of the nozzle, and the contents of the chamber or compartment *D*<sup>1</sup> will be discharged through the nozzle. The plate *G* at this time cuts off communication between the compartment *a* and the valve-chamber from which discharge is taking place. When it is turned in the opposite direction until the lug *f* is stopped by the lug *d*<sup>1</sup>, the contents of chamber *D*<sup>2</sup> are discharged, and the chamber *D*<sup>1</sup>, being open to the pipe *C*, is filled from the compartment *a*. Ordinarily, the valve would be left in the position shown in Figs. 4 and 5, with one of the chambers, *D*<sup>1</sup> or *D*<sup>2</sup>, empty, and the other in communication with compartment *a*, and full.

The upper edge of the valve-plate *G* is recessed at *g*<sup>2</sup>, to prevent the shot or other article from becoming jammed between the plate *G* and the lower end of the pipe *C*. The neck *C*, I prefer to make screw-threaded, to screw into the bottom of the canister when the canister is of wood, and it may be additionally secured by screws or bolts passing through the bottom of the canister and through lugs *I*. The valve may be opened by a knob, *F*<sup>1</sup>, or the edge of the plate *F* may be corrugated for the grasp of the hand.

The chambers *D*<sup>1</sup> *D*<sup>2</sup>, I have made to contain, each, one pound of shot, so that with every side oscillation of the valve one pound

of shot will be discharged from the nozzle; but they may be of any desired size.

The contents of each compartment of the canister is seen through apertures J, closed by glass or other transparent material.

I claim herein as new and of my invention—

The combination, with the canister A, having inclined bottom B and compartments *b*, of the oscillating measuring-valve, consisting of

the case D, having openings at C and E, diametric plate G, slotted to receive bolt H, and segmental cut-off plate or wings *g g'*, secured to one end of the diametric plate, as set forth.

HERMAN C. WEY.

Witnesses:

SAML. KNIGHT,  
GEO. H. KNIGHT.