

W. P. BORLAND & H. HOFFMANN.
Adding Machine.

No. 205,993.

Patented July 16, 1878.

Fig. 1.

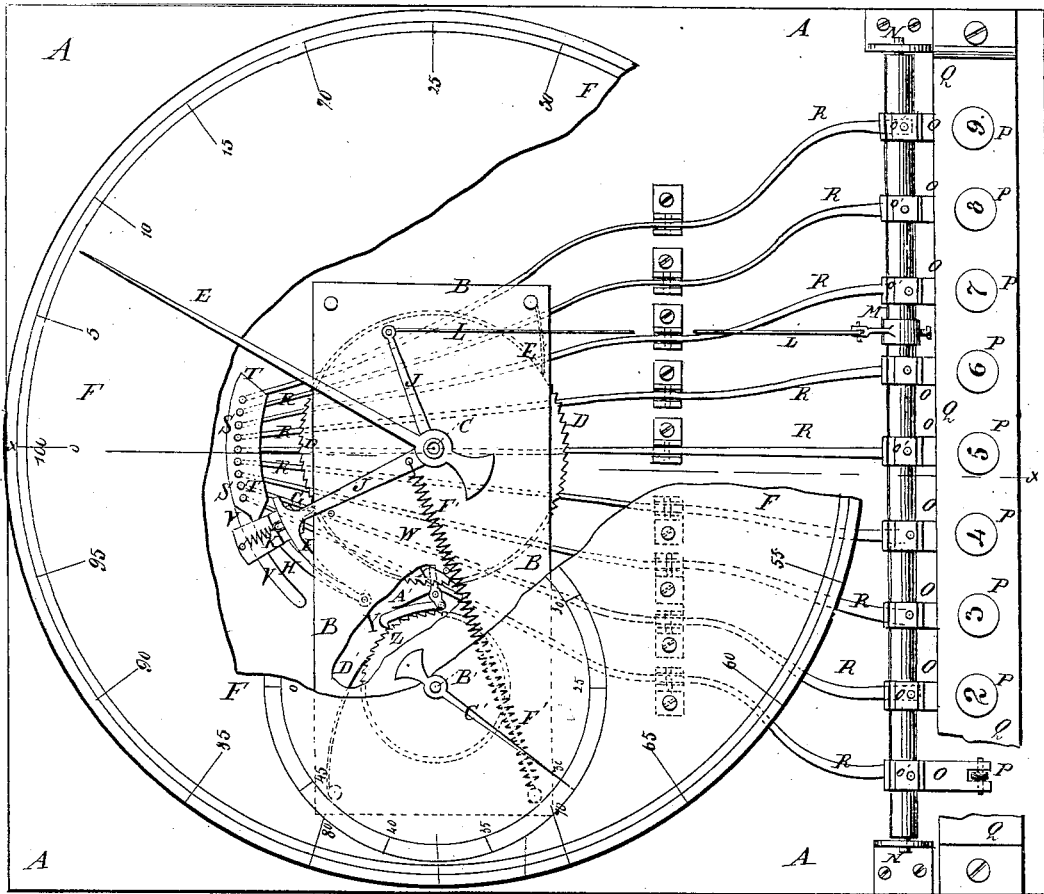
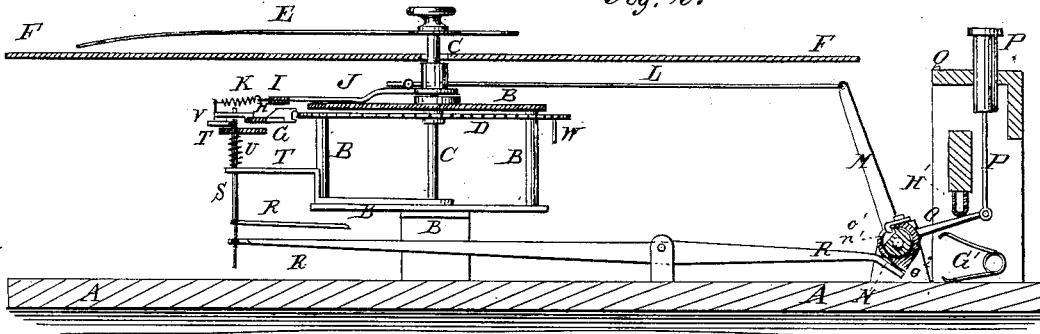

Fig. 2.



WITNESSES:

Chas. Nida
C. Sedgwick

INVENTOR:

W. P. Borland
H. Hoffmann

BY

[Signature]

ATTORNEYS.

UNITED STATES PATENT OFFICE.

WILLIAM P. BORLAND AND HERMAN HOFFMANN, OF LEAVENWORTH,
KANSAS.

IMPROVEMENT IN ADDING-MACHINES.

Specification forming part of Letters Patent No. **205,993**, dated July 16, 1878; application filed
May 14, 1878.

To all whom it may concern:

Be it known that we, WILLIAM P. BORLAND and HERMAN HOFFMANN, of Leavenworth, in the county of Leavenworth and State of Kansas, have invented a new and Improved Adding-Machine, of which the following is a specification:

Figure 1 is a top view of our improved machine, parts being broken away to show the construction. Fig. 2 is a vertical section of the same, taken through the line *x x*, Fig. 1.

Similar letters of reference indicate corresponding parts.

The object of this invention is to furnish an improved machine which shall be so constructed as to enable the user to add up a column of figures quickly and accurately, and without it being necessary for him to look at the machine, so that no time may be lost in looking from his machine to the column of figures to be added, and which at the same time shall be simple in construction, accurate in operation, and may be used with great rapidity.

The invention consists in the combination of the springs, the levers provided with pawls, the shaft provided with the notches or stops, the arm, the connecting-rod, the elbow-lever, the spring-pawl, and the retraction-spring with the toothed wheel, the shaft, the pointer, and the dial-plate; in the combination of the springs, the levers provided with cams, the shaft, the levers, the spring-pins, and the curved bar with the spring-pawl for withdrawing the said pawl from the toothed wheel; and in the combination of the pin, the lever, the pawl, and the spring with the counting-wheels for transferring motion from the one to the other of the said wheels, as hereinafter fully described.

To the upper end of the shaft C is attached of a pointer, E, which moves around the circle division-marks upon the dial-plate F, through which the said shaft C passes, and which is attached to and supported by the frame B or other suitable support. Around the edge of the dial-plate F are formed one hundred division-marks. G is a pawl, which is formed upon or attached to the end of an arm, H, the end of which is pivoted to the end of an arm,

I, formed upon or attached to the end of one arm of the elbow-lever J. The elbow-lever J is pivoted at its angle to the shaft C. The pawl G is held against the teeth of the wheel D by a spring, K, one end of which is attached to said pawl, and its other end is attached to the end of the arm of the lever J. To the end of the other arm of the elbow-lever J is pivoted the end of a connecting-rod, L, the other end of which is pivoted to an arm, M, rigidly attached to the shaft N. The shaft N works in bearings attached to the base A, and upon it are placed nine levers, O, which are kept at proper distances apart by washers placed upon the said shaft N, between the said levers, as shown in Fig. 1. To the outer ends of the levers O are attached, or with them are connected, a set of knobs, P, which knobs I prefer to have pass up through the key-board Q, so that they may be kept in proper relative position, and in such a position that they may be readily found by the fingers of the operator. The knobs or keys P are marked with the numerals in their regular order. To the forward parts of the levers O are attached, or upon them are formed, hooks or pawls o^1 , which enter notches n' in the shaft N, as shown in Fig. 2, so that the said shaft may be turned through a part of a revolution by the downward movement of the outer end of either of the said levers O, the said notches n' being made of such a length that the shaft may be turned by one of the said levers O without moving the other levers.

By this construction, by pressing the outer ends of the levers O downward, the elbow-lever J will be operated to carry the pawl G forward, turning the wheel D and shaft C and moving the pointer E forward over the dial-plate F. Upon the lower side of the inner ends of the levers O are formed cams o^2 , which, when the said levers are turned to turn the shaft N, act upon and operate the levers R. The levers R are pivoted to supports attached to the base A, and through holes in their forward ends pass the lower ends of the pins S, or of small tenons formed upon the ends of the said pins. The upper ends of the pins S pass through guide-holes

in a frame, T, attached to and supported by the frame B. The pins S are held down until raised by the levers R, and are forced down after being raised by coiled springs U placed upon their upper parts. The lower ends of the coiled springs U are attached to the said pins S, and their upper ends rest against the lower side of the top bar of the guide-frame T. To the pawl G is attached a curved bar, V, the forward end of which is beveled off, as shown in Fig. 1.

With this construction, when either of the levers O is operated to revolve the counting-wheel D, the same movement of the said lever operates a lever, R, to raise a pin, S, so that the pawl G will be withdrawn from the counting-wheel D when it has carried that wheel forward as many teeth as was indicated by the number of the lever O that was operated—as, for instance, when lever 4 is operated, the fourth pin will be raised so as to withdraw the pawl G when it has turned the wheel D through the space of four teeth. The pawl G is withdrawn from the wheel D by the inclined or beveled forward end of the curved bar V striking against the upper end of the pin S, that was raised so as to force the pawl G outward and away from the teeth of the wheel D. To the under side of the wheel D is attached a pin, W, which, at each revolution of the said wheel D, strikes against the end of a lever, X, and operates it. The lever X is pivoted to a support attached to the frame B, and to its

her end is pivoted a pawl, Y, which engages with the teeth of a toothed wheel, Z. The pawl Y is held against the teeth of the wheel Z, and at the same time the lever X is held back in position for the pin W to strike it by a spring, A', attached to the said lever X, and which bears against the said pawl Y.

The toothed wheel Z is attached to a shaft, B', which works in bearings in the frame B, passes up through the dial-plate F, and has a pointer, C', attached to its upper end. The end of the pointer C' moves along a second scale of division-marks formed upon the dial-plate F, as shown in Fig. 1, the said scale having as many marks as the wheel Z has teeth. The wheel Z is kept from being turned back by the friction of the pawl Y by a spring-pawl, D', attached to the frame B, and which rests against the teeth of the said wheel Z. The wheel D is kept from being drawn back

by the friction of the pawl G by a spring-pawl, E', attached to the frame B, and which rests against the teeth of the said wheel D. The elbow-lever J is moved back after carrying the pawl G forward to turn the wheel D by a spring, F', attached to it, and the other end of which is attached to the frame B.

By this construction the units and tens of the numbers added will be indicated by the pointer E, and the hundreds will be indicated by the pointer C'. Other counting-wheels may be added to the machine, if desired.

With this construction, as the operator becomes familiar with his machine, he can operate the levers to add the consecutive numbers of the column of figures without looking at the machine or removing his eyes from the figures being added, so that the work can be done very accurately and very rapidly.

The levers O are raised into their normal position after being lowered by the operator by means of springs G' attached to the base A, and which rest against the lower side of the levers O. As the levers O are raised by the springs G' they strike against a pad, H', of rubber or other suitable material, attached to a bar of the key-board frame, so as to prevent any jar or noise when the said levers return to their places after being operated.

Having thus fully described our invention, we claim as new and desire to secure by Letters Patent—

1. The combination of the springs G', the levers O, provided with the pawls o^1 , the shaft N, provided with the notches or stops n' , the arm M, the connecting-rod L, the elbow-lever J, the spring-pawl G K, and the retraction-spring F' with the toothed wheel D, the shaft C, the pointer E, and the dial-plate F, substantially as herein shown and described.

2. The combination of the springs G', the levers O, provided with the cams o^2 , the shaft N, the levers R, the spring-pins S U, and the curved bar V with the spring-pawl G K, for withdrawing the said pawl G K from the toothed wheel D, substantially as herein shown and described.

WILLIAM PATTERSON BORLAND.
HERMAN HOFFMANN.

Witnesses:

DAVID SIMON,
JOHN SCHOTT.