

D. E. DUTROW.
Sewing-Machine Stopper.

No. 206,094.

Patented July 16, 1878.

Fig. 1.

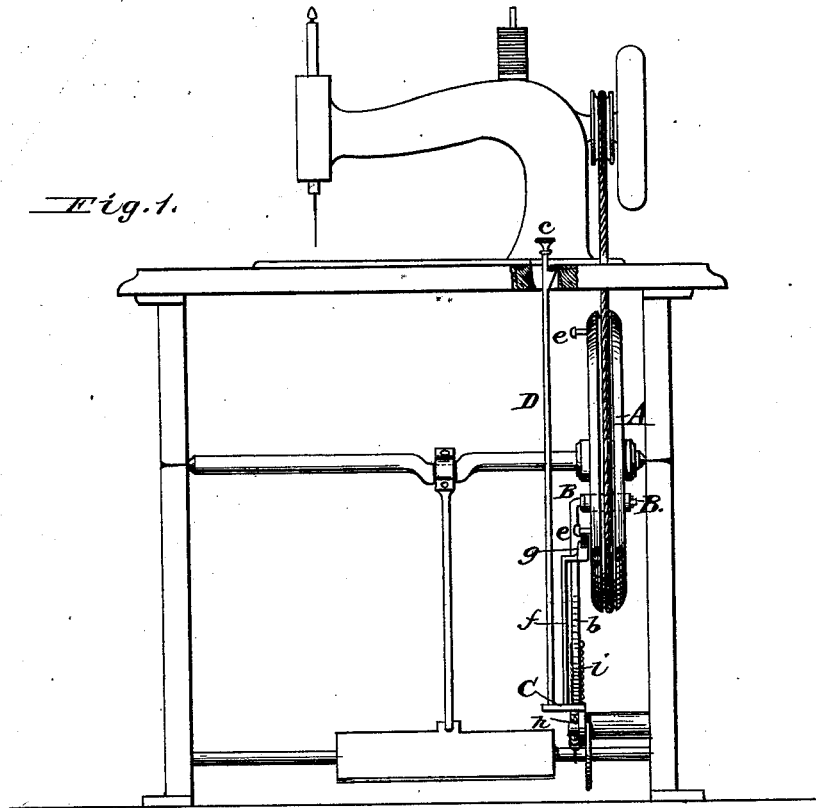
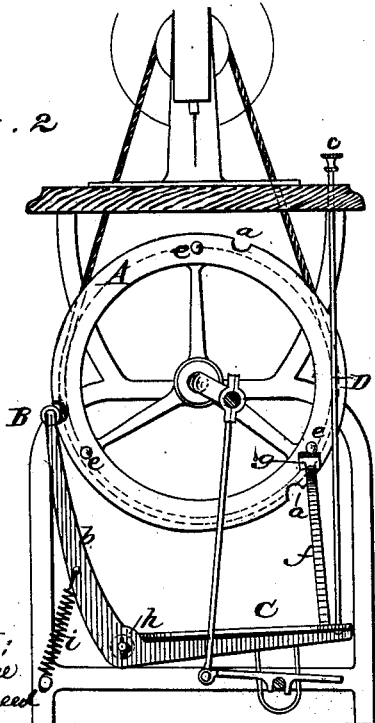
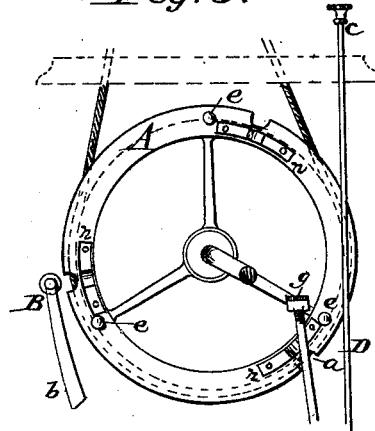

Fig. 2.



Attest:
R. L. Perrine
Daniel Breed

Fig. 3.



Inventor:
David E. Dutrow.

By *Chas. Parks*
Atty.

UNITED STATES PATENT OFFICE.

DAVID E. DUTROW, OF WASHINGTON, DISTRICT OF COLUMBIA.

IMPROVEMENT IN SEWING-MACHINE STOPPERS.

Specification forming part of Letters Patent No. **206,094**, dated July 16, 1878; application filed April 18, 1878.

To all whom it may concern:

Be it known that I, DAVID E. DUTROW, of Washington city, District of Columbia, have invented an Improvement in Sewing-Machine Stoppers; and I do hereby declare the following to be a full and correct description of the same, reference being had to the accompanying drawings, in which—

Figure 1 is a side view. Fig. 2 is an end view in section, showing the treadle depressed; and Fig. 3 is a like position, showing the treadle released.

My invention relates to an attachment to the driving-wheel of a sewing-machine whereby the machine may be stopped when the needle is in its highest position and out of the fabric, or other position, and also relates to a means of preventing the wheel, when starting, from moving backward.

My invention consists in applying an auxiliary treadle operating a pawl, which will engage notches in the periphery or side of the driving-wheel of a sewing-machine, at such points when the needle is in its highest or other position; and it consists, also, in attaching to said auxiliary treadle a stop, which, when depressed, will engage pins on the said driving-wheel and prevent a backward motion, but will not interfere with the motion of the wheel when not depressed, as will hereinafter be more fully described.

In the drawing, A represents the driving-wheel of a sewing-machine. Upon the periphery of said wheel A are notches *a*, which engage a stop, B, cushioned with rubber, leather, or such like material, upon an arm, *b*, and operated by the auxiliary treadle C. The treadle C may be operated by the side of the foot, or it may be operated by means of an elbow-stop, *c*, upon the table, and connected by a rod, D.

The notches *a* are made in the periphery of the wheel A at such places that when the stop B enters one, the needle will be at its highest point, or in any other desirable position. Upon the side of the wheel A are pins *e*, and upon the treadle C is an arm, *f*, upon the top of which is a buffer, *g*.

When the treadle is depressed, the buffer *g* is brought in the path of the revolution of the

pins *e*, and prevents a retrograde movement of the wheel A, as seen in Fig. 2; and when the treadle is released the buffer *g* is moved out of the path of the revolution of the pins, and the wheel is allowed to revolve freely, as seen in Fig. 3.

Instead of notches, separate blocks may be secured to the side of the wheel, as seen at *n*, Fig. 3, which, in some instances, may answer a better purpose than notches in the outer edge.

The operation of my device is as follows: Notches having been made in, or blocks containing notches upon, the driving-wheel or other wheel of any sewing-machine, and the forward side of said notches somewhat filed away, as shown, and the treadle C applied by means of the pin *h* and the pins *e*, placed in the sides of the wheel at points so that one will bear upon the buffer *g* when the stop B is in a notch, *a*, the device is ready for service.

It will be observed that there will be as many notches and pins upon the wheel A as the wheel is times larger than the wheel it is attached to by its band, and that when the treadle is depressed, either by the foot or arm, the stop B becomes a brake, and when it reaches a notch in the periphery of the wheel A the wheel comes to a full stop, and the buffer *g*, as well as the notch *a* and stop B, prevent a retrograde movement in starting; but when the treadle is not depressed, and is held up by means of the spring *i*, as in Fig. 3, or an equivalent weight, the wheel will act freely, as before the attachment was applied.

Having thus fully described my invention, what I claim, and desire to secure by Letters Patent, is—

1. The combination, with a balance or other wheel provided with notches *a a* and intervening spaces, of a buffer, B, treadle C, and rod D, whereby the said buffer may be caused to act upon the periphery of the wheel previous to engaging with the notches thereof, as and for the purposes set forth.

2. The driving-wheel of a sewing-machine provided with pins *e*, in combination with the buffer *g*, operated by mechanism substantially

as described, whereby the operator may control the same, substantially as described.

3. The treadle C, carrying the stop B and buffer g, in combination with the rod D and arm-stop e, whereby said stop and buffer may be operated by the arm of the operator, substantially as described.

The above specification of my said invention signed and witnessed at Washington this 12th day of April, A. D. 1878.

DAVID E. DUTROW.

Witnesses:

C. M. PARKS,

JOHN T. C. CLARK.