

B. F. BELLOWS.  
Type Writing Machine.

No. 206,160.

Patented July 23, 1878.

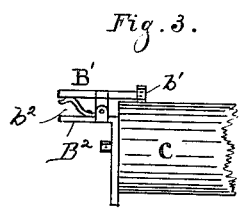
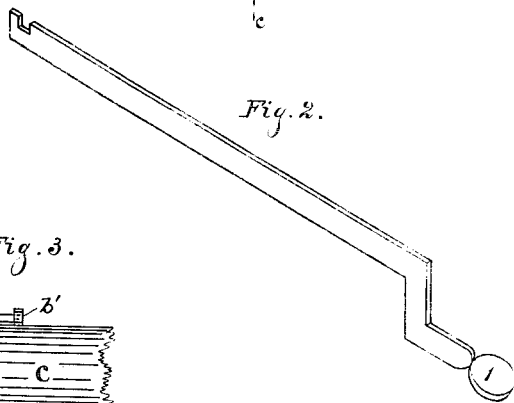
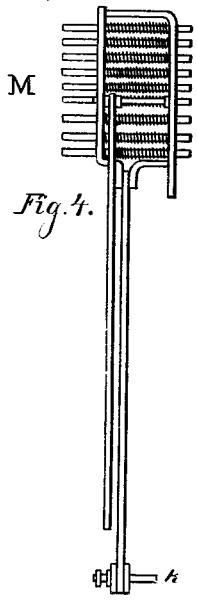
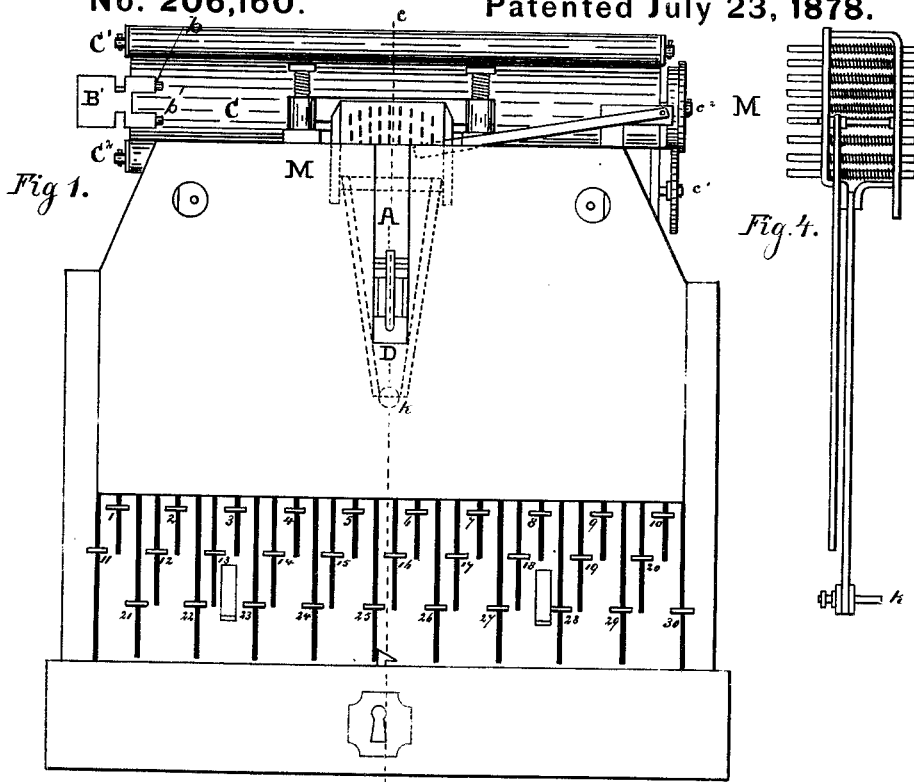

WITNESSES:  
*L. P. Harlan.*  
*L. R. Morrison.*

INVENTOR:  
*Benjamin F. Bellows*  
*per C. Bradford.*

ATTORNEY.

# B. F. BELLOWS. Type Writing Machine.

No. 206,160.

Patented July 23, 1878.

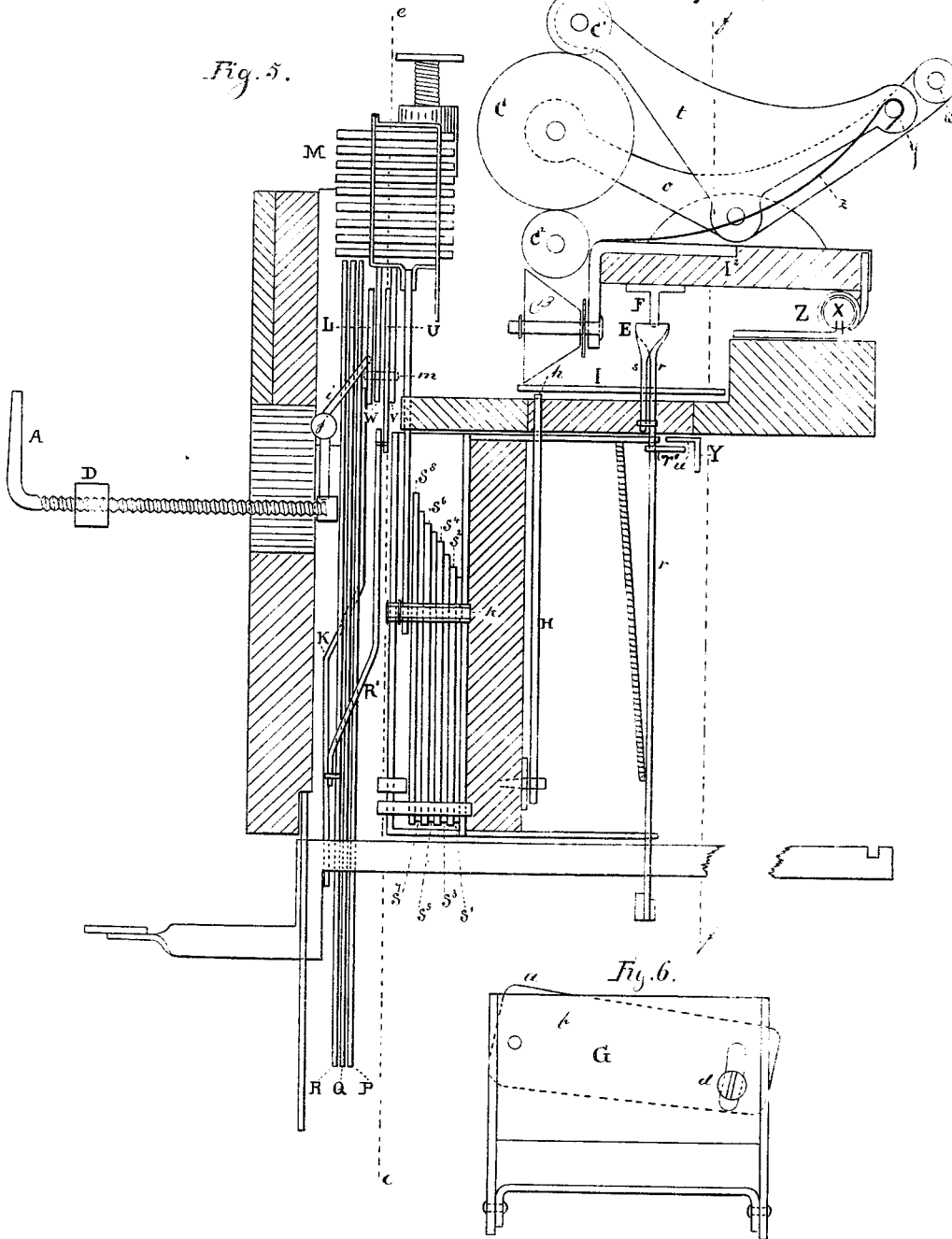

WITNESSES:  
*W. H. Harrison*  
*W. R. Morrison*

INVENTOR:  
*Benjamin F. Bellows*  
*per C. Bradford*  
 ATTORNEY.

# B. F. BELLOWS. Type Writing Machine.

No. 206,160.

Patented July 23, 1878.

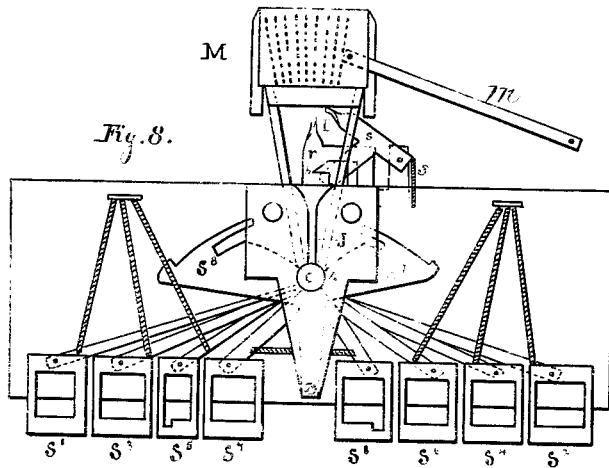
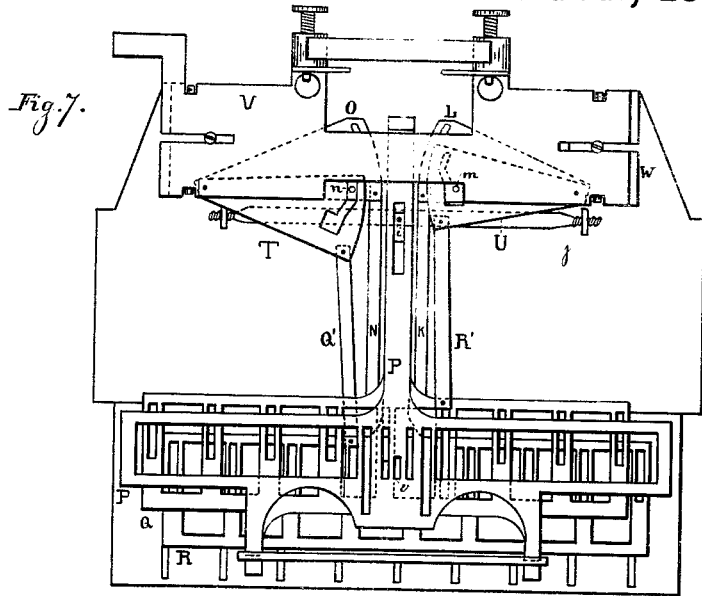

WITNESSES:

*L. P. Adams.*  
*E. R. Morrison*

INVENTOR:

*Benjamin F. Bellows*  
per *C. Bradford*

ATTORNEY.

# B. F. BELLOWS. Type Writing Machine.

No. 206,160.

Patented July 23, 1878.

Fig. 9.

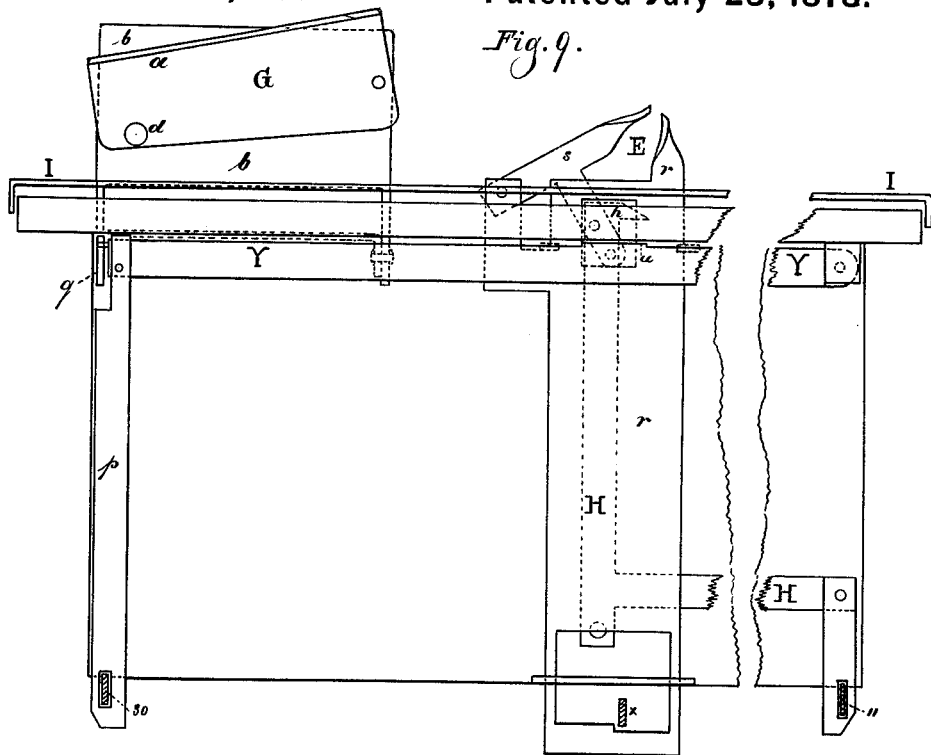
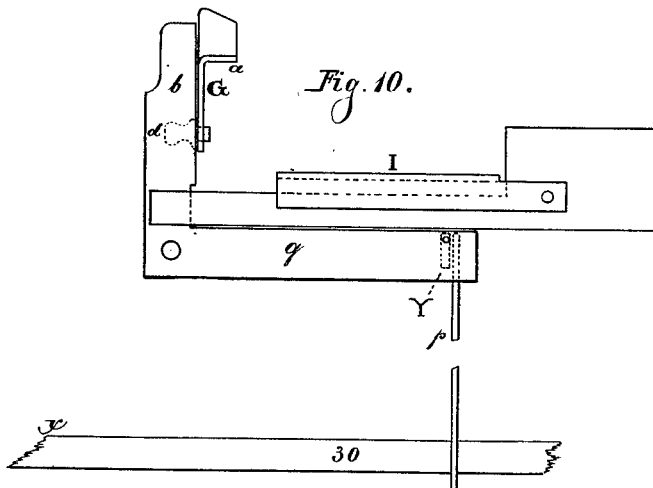

Fig. 10.



WITNESSES:

*L. P. Harlan.*  
*G. R. Morrison.*

INVENTOR:

*Benjamin F. Bellows.*  
per *C. Bradford.*  
ATTORNEY.

# UNITED STATES PATENT OFFICE.

BENJAMIN F. BELLOWS, OF WEEPING WATER, NEBRASKA.

## IMPROVEMENT IN TYPE-WRITING MACHINES.

Specification forming part of Letters Patent No. **206,160**, dated July 23, 1878; application filed April 16, 1877.

*To all whom it may concern:*

Be it known that I, BENJAMIN FRANKLIN BELLOWS, of Weeping Water, county of Cass, and State of Nebraska, have invented certain new and useful Improvements in Type-Writers, of which the following is a specification:

Reference is had to the accompanying drawings, which are made a part hereof, and on which similar letters and figures indicate similar parts.

The object of my invention is to provide an efficient means of writing with type or printing a single copy in cases where it has been usual to produce the writing desired with a pen.

This is accomplished by a machine constructed for the purpose, and which is generally known as a "type-writer."

Figure 1 is a front view of my invention. Fig. 2 is a perspective view of one of the keys. Fig. 3 is a view of attachment B for holding cards. Fig. 4 is a side view of the type and the type-holder M. Fig. 5 is a sectional plan drawn for the most part through the dotted line *c c*, but varied from said line in places in order to illustrate as much as possible of the invention when looking into the machine from the right-hand side. Fig. 6 is a front plan of spacing contrivance G. Fig. 7 is a view of the inside of the front part of the machine when viewed from a point corresponding with the dotted line *e e* in Fig. 5. Fig. 8 is a view of the parts immediately in the rear of those shown in Fig. 7, as shown when looking rearwardly from the same dotted line *e e*. This line is varied from at the top of the figure, in order to get a front view of the type-holder M. Fig. 9 is a view of propelling and holding catch E and the various levers and attachments near to or connected with it when looked at from a point shown by the dotted line *f f*. This figure also gives a view of key 30 and the levers attached thereto. Fig. 10 is a view of key 30 with its connections, and of the spacing contrivance G.

In the drawings, the numerals 1 to 30, inclusive, represent the keys, which are arranged to work as follows:

1, if struck alone, causes the hammer A to strike on the small or lower-case letter *a*, and thus makes that impression on the paper. If

struck in combination with 6, and while 6 is yet down, its operation is changed to the capital letter A, while in combination with 5 the numeral 9 is formed. 2, in the same manner, alone makes *b*; with 6, B; with 5, :: 3 alone makes *c*; with 6, C; with 5, ' 4 alone makes *d*; with 6, D; with 5, 7. 5, when used in connection with the working keys, makes the numerals and various stops and marks. 6, when used in connection with the working-keys, changes the letters from lower-case to capital letters.

The operation of these two keys 5 and 6 is hereinafter more particularly described.

Keys 7, 8, 9, 10, 12, 13, 14, 15, 16, 17, 18, 19, 20, 21, 22, 23, 24, 25, 26, 27, 28, and 29 operate in a similar manner to keys 1, 2, 3, and 4, and complete the entire list of seventy-eight characters now used with this machine, including letters, both lower case and capital, and the stops and numerals.

Key 11 is used in combination with the elbow-lever H, having the beveled head *h* on its upright portion to raise the bed-plate I, which, in turn, raises the paper-holding apparatus a sufficient distance so that the dash-mark can be used as an underscoring attachment.

Key 30, through the levers *p* and *q*, moves the spacer G so as to engage it with the gear-wheel *c*<sup>1</sup> on the end of roller C<sup>2</sup>, and which, in turn, engages with gear-wheel *c*<sup>2</sup> on end of roller C, and thus turns said rollers while they are being run back, so as to give the necessary space between the lines of writing on the paper. This space can be made wide or narrow at pleasure by setting the incline *a* at a greater or less angle. The incline *a* is held in its place by the set-screw *d*, which runs through the slot in the carrier-bar *b*.

The type are closely arranged in the type-holder M, so that the hammer A can reach each one without danger of missing by reason of a too great movement of the type-holder M.

The handle of the hammer A is provided with a screw-thread, on which runs the weight D. This weight enables the operator to give a lighter or heavier stroke on the type at will by simply running the weight farther from or nearer to the point of the hammer, the hammer, of course, striking heaviest when the weight is nearest the point.

The type are arranged in three perpendicular sections of three rows each. The right-hand section is capitals, the central section is small or lower-case letters, and the left-hand section is the stops, marks, and numerals.

If the working-keys alone are used, the central or lower-case section is under the operation of the hammer. If the capitals are wanted, in addition to the working-keys, use operating-key 6. If stops, marks, or numerals are wanted, use in connection with the working-keys the operating-key 5.

Key 5 pulls down lever K, which is jointed to plate L, which is, in turn, jointed to the front part of the machine. The plate L has an inclined slot, which runs over pin *m* in plate W, and which draws said plate W, with its companion-plate V, to the right, and with them the type-holder M, whereby the left section of type is brought under the operation of the hammer A.

Key 6 pulls down the lever N, which is jointed to the plate O, which is, in turn, jointed to the front part of the machine. The plate O has an inclined slot, which runs over the pin *n* in plate W, and which draws plates W and V to the left, whereby the right section of type is brought under the operation of the hammer A.

The plate V has a projection, V', to which the type-holder M is connected by means of the connecting-rod M', and by means of which the type-holder is made to follow the motion of the plates. The type are also arranged in nine horizontal rows, and each row is raised to position to be struck by the arrangement of levers shown in Fig. 8.

The pivot *k* on the bottom of the stem of the type-holder rests in the slot J. When the pivot *k* is at the bottom of the slot, the first or top row of type is in position to be struck, and the keys for this row do not pass through the loops of any of the levers; but when the second row is to be struck the keys run through the loop of lever S<sup>1</sup>, then the third through the loop of S<sup>2</sup>, and so on, the lever S<sup>8</sup> raising the type-carrier, until the bottom or ninth row of type is in position for use.

Inside the front part of the machine are arranged the three slides P, Q, and R, through which the stems of the keys run, and which, when struck by the keys, draw down the pin *i* in hammer-shaft *j*, and thus strike the hammer A against the rear end of the proper type. They also, by means of various connections, shift the type-holder M a single space, so that the right and left hand rows of the sections may be used.

The slide P is not connected with either of the plates, and, consequently, when keys are struck which rest on this slide alone the plates are not moved, and the hammer A strikes the central row of whichever one of the perpendicular sections is being used.

The slide Q is connected with the plate T by means of the lever Q'. The plate T is pivoted to the plate V, and has an inclined slot,

which runs over pin *n* in plate W, whereby the plate V, which carries the type-holder M, is carried one space to the left, and the right-hand row of any section is brought under the operation of the hammer A.

The slide R is connected to the plate U by the lever R'. The plate U is pivoted to the plate V, and has an inclined slot, which runs over the pin *m* in plate W, whereby the plate V and type-holder M are carried one space to the right, and the left-hand row of any section of type is brought into use.

Immediately in the rear of the levers S<sup>1</sup> to S<sup>8</sup> is the propelling and holding catch E. This catch is composed of the upright standard *r* and pivoted jaw *s*, and is driven by means of the lever *x*. (Shown in Fig. 9.) This key fits closely into the small slot *a*, (shown in Fig. 7,) and thereby closely follows every movement of the slide P, and as the slide P is worked by every one of the working keys the standard *r* is, of course, pulled downward by each stroke on any of them. Whenever the catch is pulled down and disengaged, the jaw *s* flies upward and backward, and engages a tooth in the rack-bar to the right of the one disengaged, and, as the catch rises, the jaw *s* comes forward and downward, and pushes the rack-bar F a space farther to the left, thus giving room for another letter on the paper. The stationary jaw on the upper end of the standard *r* engages the opposite side of the tooth which is being pressed against by the jaw *s*, and thus holds the rack-bar and all of the parts fastened thereto firmly in position while the type is making its stroke.

The paper-holding attachment is composed of the three rolls C, C', and C<sup>2</sup>, which are held in place by the arrangement of levers and springs shown in Fig. 5, and is propelled in the proper direction and to proper distances by the action of the spacer G and catch E, described above.

The roll C is held in place by the pivoted lever *o*, and the roll C' by the pivoted lever *t*. On the rod *y* is the spring *z*, which is fastened at the other end to the bed-piece I<sup>2</sup>. This spring *z* presses the roll C' downward, and with it the roll C, as the roll C' is on top; otherwise a second spring would be needed.

The levers *o* and *t* and the spring *z* are duplicated at the opposite ends of the rolls, and are connected together by the rods *w* and *y*.

The paper-holding attachment runs on a slide or carriage composed of the rod X and partly-open tube Z, so arranged that it will slide from either end of the machine without difficulty, and can be replaced at pleasure.

The main roll C has an attachment, B, for holding postal or other cards, or pieces of paper too small to reach under the smaller rolls. It consists of two flat pieces, hinged together, and the inner end is pressed upon the roll C by means of a spring in the outer end.

In Fig. 9 is shown the lever Y. This lever has a projection, *u*, which engages the pin *r'* in standard *r*, and is pivoted to the lever *g*,

so that when the key 30 is pulled down it also pulls down the catch E, and thereby relieves the rack-bar F from all interference while being run back.

The operation of my machine is to speedily and easily write any matter that may be desired, in either lower-case or capital letters, with all numerals and necessary stops and marks. One of its most marked advantages is that it makes nearly twice the number of characters that have been made by machines heretofore invented with a much less number of keys. I use only twenty-six working and four operating keys, making thirty in all, and make seventy-eight characters, while others have generally used over forty keys, each capable of making only a single character.

I disclaim, however, all that part of this invention which relates to the combination of the combined hinge and guide-rail with the paper-carriage, by which said carriage is enabled to be moved along and over the machine and up and off from the same. I also disclaim the combination of a ratchet-bar with such a device, and also the combination of a hinge and guide-rail on one side and a traveling-wheel on the other with such a carriage; but,

Having thus fully described my said invention, what I do claim as new, and desire to secure by Letters Patent, is—

1. In a type-writer, the combination of the case of printing-characters M with the hammer A, said hammer being operated by the keys, in combination with slide P, pin *i*, and shaft *j*, substantially as herein shown and described.

2. The combination of working-keys, slides P, Q, and R, and operating-keys 5 and 6, attached to mechanism, substantially as described, to operate the type-holder M, as herein shown and described.

3. The combination of movable jaw B<sup>1</sup>, provided with small rollers *b<sup>1</sup> b<sup>1</sup>*, with permanent jaw B<sup>2</sup> and spring *b<sup>2</sup>*, forming the catch B, all as herein shown and described, and for the purpose herein specified.

4. The combination of hammer A with weight D and operating mechanism, substantially as described, for the purpose specified.

5. The propelling and holding catch E, composed of the jaw *s*, pivoted to the upright *y*, in combination with the rack-bar F, as herein shown and described.

6. The pivoted jaw *s* having spring *s'*, in combination with the vertically-moving stand-

ard *r*, forming the catch E, as herein shown and described.

7. The combination of slide P, lever *x*, and vertically-sliding catch E, as herein shown and described.

8. The combination of key 11 with elbow-lever H and bed-plate I, as and for the purposes specified.

9. The combination of key 30, levers *p* and *q*, spacer G, and gear-wheel *c'*, substantially as herein shown and described, and for the purpose specified.

10. The combination of the adjustable and movable inclined spacer G, composed of the incline *a*, carrier-bar *b*, and set-screw *d*, as herein shown and described.

11. The combination of working-keys, slide P, pin *i*, and hammer A, as herein shown and described.

12. The combination of key 6 with levers N and plate O, having slot which passes over pin *n*, for the purpose of moving the type-holder M from one position to another, as herein shown and described.

13. The combination of the working-keys with slides Q, lever R', and plate U, having slot which passes over pin *m*, as herein shown and described.

14. The combination of the cam-faced levers with the type-holder M, as and for the purposes specified.

15. The projection *u*, attached to lever Y, in combination with pin *r'* in standard *r*, as herein shown and described.

16. The paper-holding attachment composed of main roll C and smaller rolls C<sup>1</sup> and C<sup>2</sup>, in combination with spring *z*, as herein shown and described.

17. The combination of slide Q, lever Q', plate T, and pin *n*, as and for the purposes specified.

18. The working-keys, in combination with cam-faced levers, for the purpose of raising the type-holder M, as herein shown and described.

19. The combination of the plate V, connecting-rod M', and type-holder M, as herein shown and described.

In witness whereof I have hereunto set my hand, at Indianapolis, Indiana, this 30th day of March, A. D. 1877.

BENJ. F. BELLOWS.

In presence of—

CHESTER BRADFORD,  
MARCUS L. HARRIS.