

J. E. WHEELER & M. V. B. ETHRIDGE.
 Lasting Machine for Boots and Shoes.

No. 206,203.

Patented July 23, 1878.

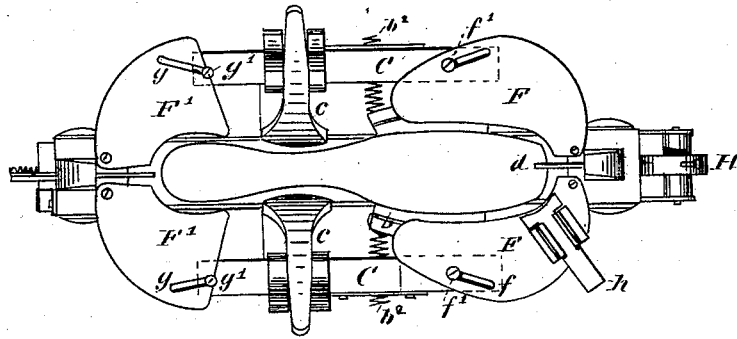

Fig. 1.

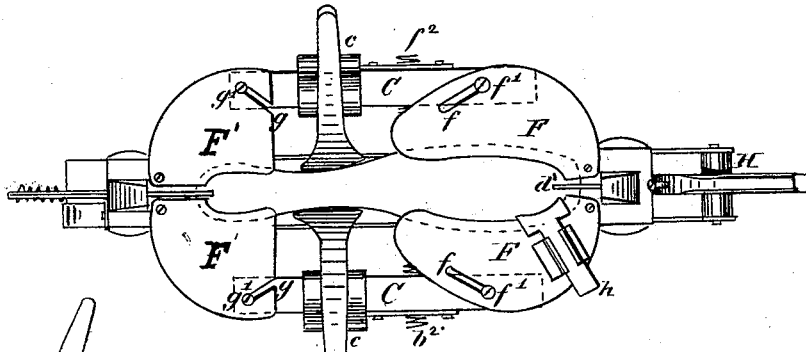

Fig. 2.

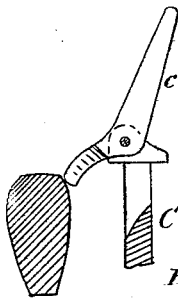

Fig. 5.

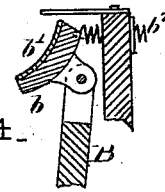

Fig. 4.

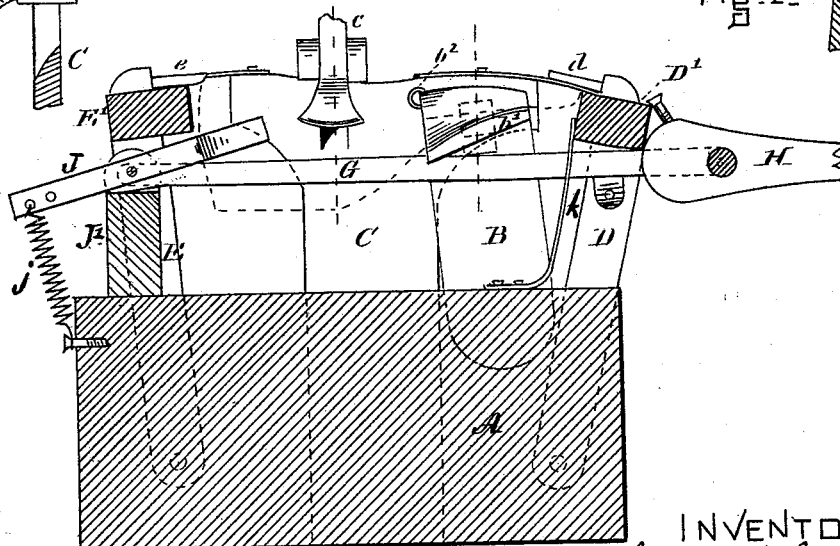

Fig. 3.

WITNESSES

F. F. Raymond
A. J. Ottenger

INVENTOR
John E. Wheeler
Martin V. B. Ethridge
 by their attys
Thos. W. Milburn

UNITED STATES PATENT OFFICE.

JOHN E. WHEELER, OF LYNN, AND MARTIN V. B. ETHRIDGE, OF BOSTON,
MASSACHUSETTS; SAID ETHRIDGE ASSIGNOR TO SAID WHEELER.

IMPROVEMENT IN LASTING-MACHINES FOR BOOTS AND SHOES.

Specification forming part of Letters Patent No. **206,203**, dated July 23, 1878; application filed
March 11, 1878.

To all whom it may concern:

Be it known that we, JOHN E. WHEELER, of Lynn, in the county of Essex, and MARTIN VAN BUREN ETHRIDGE, of Boston, in the county of Suffolk, and State of Massachusetts, have invented an Improvement in Lasting-Machines for Boots and Shoes, of which the following is a specification:

This invention relates to mechanism for lasting boots and shoes; and consists in the combination of rocking toe and heel blocks, simultaneously actuated and moved toward each other and upon the last by a cam-lever and link motion; of lasting-plates shaped upon their inner edges to correspond substantially with the general outline of the last, at its sole-edge, at that portion of the last upon which they close at its sole-edge, pivoted at one end to the movable toe and heel blocks, and moved with them, and guided and controlled in their motion upon the shoe by means of slots in said plates and guide-pins attached to a stationary part of the machine; and in shank-lasting rubbing-leathers attached to the stationary part of the machine; and in an adjustable divided instep-bed at the fore part of the machine, in combination with toe and heel downholds projecting over the shoe from the toe-block; and in a spring-lever jaw, to clamp and steady the heel in the operation of lasting.

In the drawing, Figure 1 is a top view of the machine open. Fig. 2 is a top view of the machine closed. Fig. 3 is a longitudinal vertical section. Fig. 4 is a transverse vertical section of one-half of the instep-rest; and Fig. 5 is a transverse vertical section, illustrating the operation of the shank-lasting levers.

This lasting-machine belongs to that class of lasting-machines in which the leather is folded over upon the insole by means of plates more or less conformed to the shape of the shoe. It has been heretofore usual to have plates attached to jaws moving to and from the sides of the last, and to have them conform in shape to the sides of the last, except for a short distance at the toe and heel; or to close a series of folding slides upon the surface of the last simultaneously by suitable actuating mechanism. The object, also, has generally been to clamp the leather to the side

of the last by means of pads or jaws moving up to the sides, and conformed to the shape of the sides; and divided or sectional folding-plates, moving from standards actuated by cams, have also been used to fold the edge of an upper upon a last by a horizontal closing movement.

It is, however, to be remarked that in the operation of lasting, if a good fit is obtained over the ball of the foot and the leather is properly stretched toward the toe and heel, the use of pads or clamps upon the side is unnecessary.

Upon a suitable base, A, we erect two standards, B. At the top of each of these is hinged a block, *b*, shaped on its interior surface to conform to the outline of the last, and lined with a compressible or elastic material, as shown at *b*¹, and having its upper edge attached to a spring, as shown at *b*². On lowering the last into this pair of blocks, it comes in contact with the inner surface of them, and the lower portion of the block is depressed and the upper edge rocked inward upon the leather, thus lifting, clamping, and smoothing it upon the last. The operation of depressing the last into this rolling bed is performed by the toe-downhold *d*, attached to the toe-block; and moved up with it into place by means of a cam-lever, H. The under surface of the toedownhold, as well as that of the heel-downhold *e*, is so shaped that in closing horizontally upon the last the end of the same strikes or contacts with the edge of the outsole, and by the continued closing of the two downholds the last is lowered, the downhold performing substantially the functions of cams in lowering the last into the blocks *b*.

The springs *b*² are fastened to the side frames C. These two side frames carry the shank-lasting levers *c*, pivoted to the side frames at their top, and having rounded ends, which engage with the sides of the last at the place where the shank rounds into the body of the foot, and are so hung that the arc described by them shall smooth and fit the leather upon the shank part of the last. The lever D, at the toe, carries at its top a block, D', upon which is mounted the toe-downhold *d*, on each side of which are hinged the vamp-lasting plates F.

Slots f in the forward end of the sides of these plates fit upon pins f' in the top of standard C. The plates F are curved on their interior surfaces to correspond somewhat to the horizontal contour of the last, and shaped to substantially conform to that portion of the sole-edge of the last upon which they are designed to operate. The slots and pins $f f'$ are so arranged with regard to each other that on moving up the block D' the plates F F will receive a movement in the direction from toe to heel of the last, and also a closing motion somewhat similar to a pair of scissors. A knife, h , is so arranged upon these plates that when they are brought into position it may be slid forward to skive the puckered leather lasted at the toe.

The heel-block E' is mounted on the lever E, carries a heel-downhold, e , at its center, has a pair of plates, F', pivoted on either side of the downhold, which plates are conformed and shaped to the configuration of the heel, as the plates F F are conformed and shaped to the configuration of the forward part of the last, and they are governed by slots and pins arranged on the top of the standard C in a similar manner. Said slots and pins are lettered g and g' . In order to draw up the levers D E, a link, G, is attached to lever E at one end, and at the other to cam-lever H, which bears against the toe-block D' and its lever D. Springs k are arranged to throw back the heel and toe levers D and E. They are illustrated in the drawing only as pressing against the toe-block D' in Fig. 3; but a similar spring is provided in a corresponding place to press back the heel-block E'.

To center, fix, and adjust the heel of the last in the apparatus, the forked lever J is employed, which is mounted upon a fixed standard erected from the base A, and is depressed at its outer end by means of the spring j .

The method of drawing together by link and cam motion the heel and toe blocks is shown in a former lasting-machine, and which is known as the "Ethridge machine;" but that machine did not have a similar arrangement and operation of the lasting-plates.

We claim as our invention, and desire to secure by Letters Patent, in a lasting-machine—

1. The combination of the divided rocking fore block b , either with or without a compressible or elastic lining, b^1 , and hinged or pivoted to the standards B, as shown, with

the said standards B and the springs b^2 , whereby the upper is clamped on a last by the upward rocking movement of said divided fore block upon the same when the last is compressed therein, substantially as described.

2. The combination of the divided rocking fore rest b , either with or without an elastic or compressible lining, b^1 , with the standards C and springs b^2 , the said fore blocks acting, when the last is compressed therein, to clamp the upper upon the same in relation to the sides of the last, substantially as described.

3. The combination of the divided rocking fore block b , arranged and operating substantially as described, with the yielding forked lever J, provided with suitable connecting mechanism for operating the lasting-plates, all operated together substantially as described.

4. The combination of the divided rocking fore block b , arranged and operated substantially as described, with the closing levers and blocks D D' E E', and their holding and depressing downholds $d e$ and suitable connecting mechanism, all operating together substantially as described.

5. The combination of the closing heel and toe blocks $d' e'$ with the fore-lasting and heel-lasting plates F and F', pivoted to said heel and toe blocks, and guided by pins upon the standards C, and operated by the closing of said heel and toe blocks, substantially as and for the purpose described.

6. The combination of the lasting-plates F F', respectively, with the side standards C and movable toe and heel blocks D' E' by means of pivoted connections on the toe and heel blocks and slots and pins $f f' g g'$, for the purpose of giving to said plates $f f'$ longitudinal and transverse closing and sliding motion, substantially as and for the purpose described.

7. The combination, with the toe and heel lasting plates F F', operated by the closing of the toe and heel blocks D' E', of the shank-lasting levers c , pivoted to the said standards C, and conformed at their inward edges to fit the shank of the last, and adjusted to fit the leather thereon, substantially as described.

JOHN E. WHEELER.

MARTIN V. B. ETHRIDGE.

Witnesses:

F. F. RAYMOND, 2d,
GEORGE F. WALKER.