

J. A. HOUSE.
Sewing-Machine.

No. 206,239.

Patented July 23, 1878.

Fig 1.

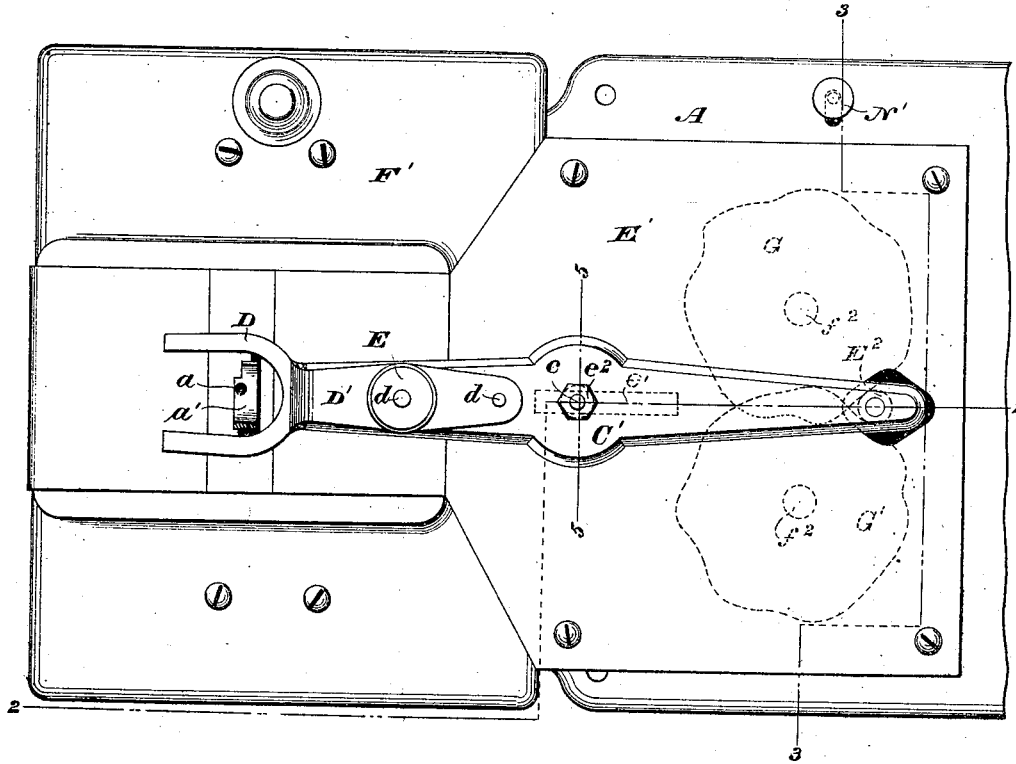

Fig 2.

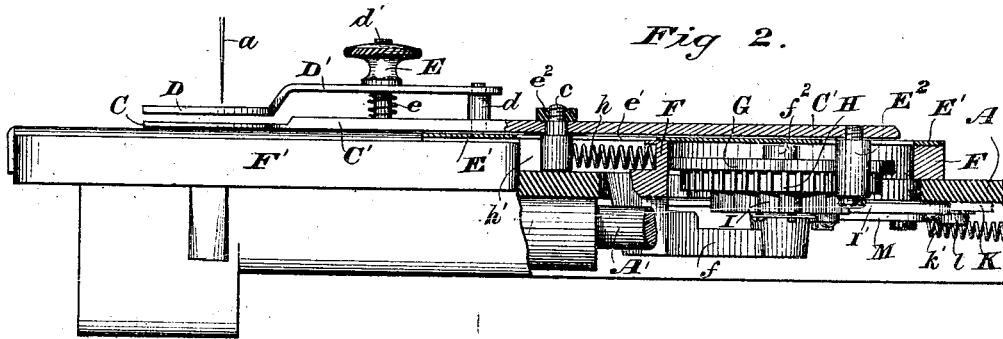
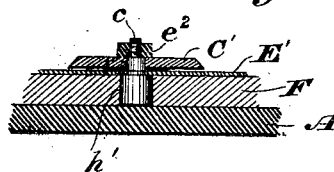

Fig 5.



WITNESSES

Wm A Skinkle
Robertson Buchanan.

INVENTOR

By his Attorneys

James A House
Adams, Hopkins & Layton.

J. A. HOUSE.
Sewing-Machine.

No. 206,239.

Patented July 23, 1878.

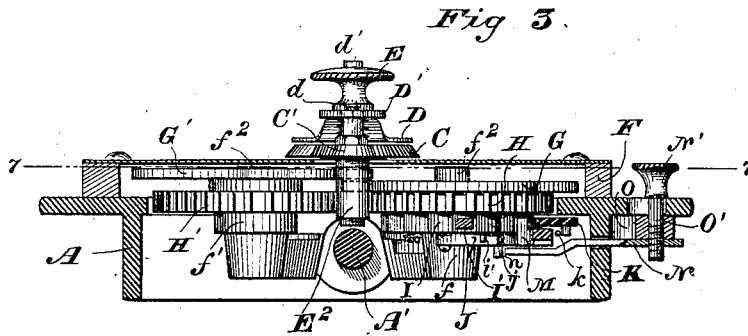
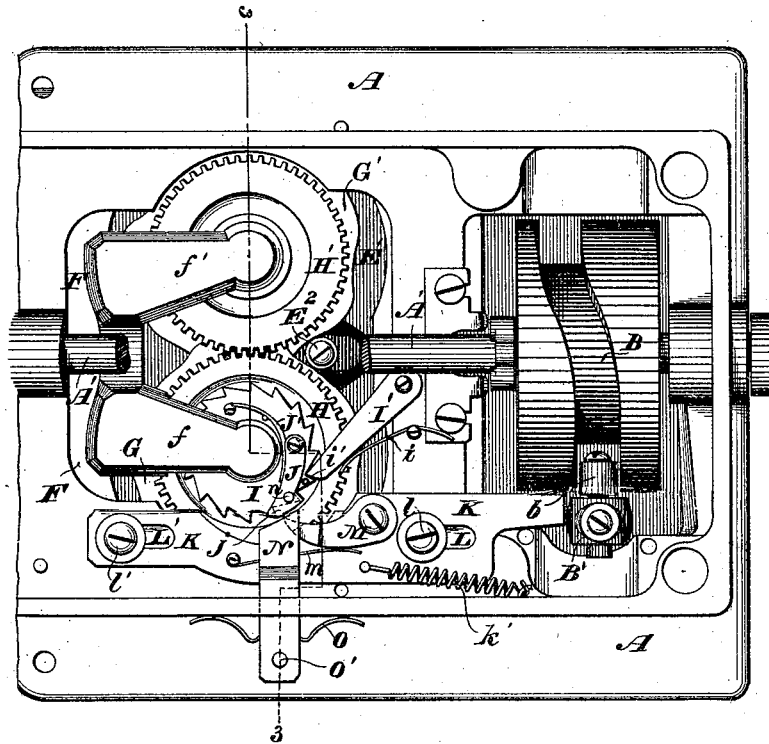

Fig 4.



WITNESSES

Wm A Skinkle
Robertean Buchanan.

INVENTOR

James A House
By his Attorneys
Baldwin, Hopkins & Lynde.

J. A. HOUSE.
Sewing-Machine.

No. 206,239.

Patented July 23, 1878.

Fig 7.

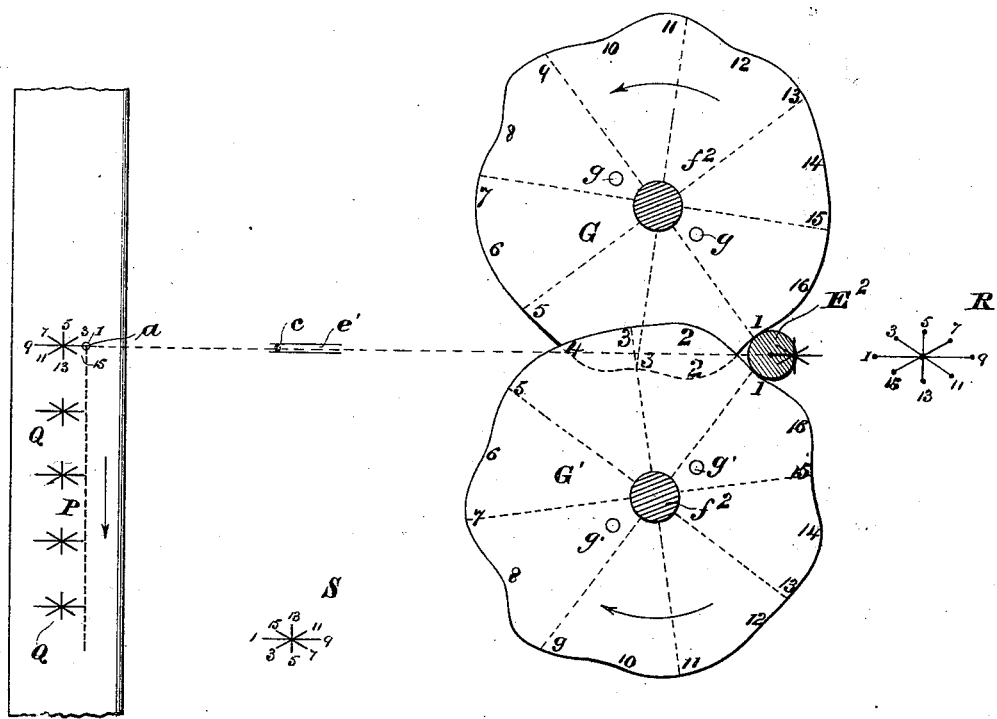
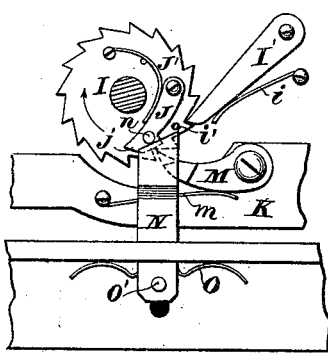

Fig 6.



WITNESSES

Wm A Skinkle
Robertson Buchanan,

INVENTOR

By his Attorneys
James A House
Baldwin, Hopkins & Weston.

UNITED STATES PATENT OFFICE.

JAMES A. HOUSE, OF BRIDGEPORT, CONNECTICUT.

IMPROVEMENT IN SEWING-MACHINES.

Specification forming part of Letters Patent No. 206,239, dated July 23, 1878; application filed May 20, 1878.

To all whom it may concern:

Be it known that I, JAMES ALFORD HOUSE, of Bridgeport, in the county of Fairfield and State of Connecticut, have invented certain new and useful Improvements in Sewing-Machines, of which the following is a specification:

My invention relates to improvements in feeding devices or attachments for sewing-machines for ornamental stitching, such as embroidery and flossing, and for working button-holes and eyelets, especially designed for the well-known Wheeler & Wilson machine. My improvements are, however, applicable to other machines which make the lock-stitch. In this instance they are shown as adapted to the Wheeler & Wilson No. 6 machine, which is generally similar to the sewing-machines illustrated and described in an application for Letters Patent of the United States filed by me May 8, 1878, and in sundry Letters Patent of the United States heretofore granted me, particularly the patent dated March 5, 1872, No. 124,360.

My objects mainly are to provide an attachment by which to work ornamental figures, button-holes, &c., at the side of or laterally to and joining with a connecting line of stitching made by the usual and regular operation of the machine, and so to combine the attachment and its supplemental feeding devices with the machine and its usual and regular feeding mechanism as to admit either of the usual stitching being intermitted at any desired intervals and the connected lateral ornamental or button-hole stitching performed during the pauses in the formation of the usual row of stitches, or of the employment of the attachment and its feeding devices without the connecting row of stitching between the successively-worked figures, button-holes, &c.

My improvements consist in novel organizations of parts, and in certain combinations of devices hereinafter first fully described, and then specifically designated by the claims.

In the accompanying drawings, which show so much of a completely-organized sewing-machine as is necessary to illustrate the invention herein claimed, I have shown one way of embodying my improvements.

Figure 1 is a plan or top view, with the

overhanging portion or bracket-arm of the frame, the needle-lever, &c., omitted, the presser-foot in section, and one form of the cams or pattern-wheels in dotted lines; Fig. 2, a view, partly in side elevation and partly in vertical section on the line 2 2 of Fig. 1, with the main driving-shaft broken away; Fig. 3, a transverse vertical section on the line 3 3 of Fig. 1, with some of the parts also in section on the line 3 3 of Fig. 4; Fig. 4, a bottom view, with the main driving-shaft broken away to more clearly show the supplemental feeding devices. Fig. 5 is a section on the line 5 5 of Fig. 1, showing the fabric-clamp, its roller, and the manner of pivoting the clamp; Fig. 6, a view in detail, showing the devices, as seen from the under side, for operating and stopping the supplemental feed. Fig. 7 is a diagram, with parts in section on the line 7 7 of Fig. 3, to more clearly show the operation of the attachment.

A frame-bed, A, and suitable overhanging arm or bracket support the various moving parts of the machine, which are in this instance, unless it is hereinafter otherwise stated, the same as or substantially similar to the improvements shown and described or suggested as modifications in my prior patents, particular reference being here made to the before-recited Patent No. 124,360. The driving-shaft A' is provided with suitable cams to operate the take-up and the needle *a*. A roller, *b*, at the lower end, B', of the needle-lever is acted upon by a groove, B, in the needle-cam, and a rotary hook to seize and expand the loop of needle-thread is driven and operates as fully explained in my said patent. The usual presser-foot *a'* and fabric-feed are employed.

A suitable sectional supplemental fabric-clamp, forming part of my attachment, is shown as composed in part of a centrally-open horse-shoe-shaped or U-formed plate, C, formed with or attached to the outer end of a long arm or lever, C', fulcrumed on a pivot, *c*, intermediate its ends. The upper part of the clamp is formed by the correspondingly-shaped plate or outer end D of a short arm or plate, D', bent downward at its termination in the upper clamp-section and supported at its inner end upon a shouldered post, *d*, upon which it fits loosely. A stud post or upright rod, *d'*, thread-

ed at the upper end, passes through the arm D' , between its clamping end D and the post d , upon which the perforated inner end of this arm is supported. The threaded stud d' is fastened in the lever C' at bottom, and an expansive spring, e , encircles the post, and bears at its opposite ends upon the lever and against the arm of the top section of the clamp. The spring operates with a tendency to move the upper clamp-section away from the lower one. A thumb-nut, E , upon the end of the post d' , above the arm D' , may be adjusted so as to compress the spring and bring the clamp-sections together, or bring them sufficiently near each other to clamp the fabric securely and give to it the movements of the clamp imparted by the supplemental feed devices hereinafter to be described.

The inner or adjacent surfaces of the clamp-sections are roughened or serrated as usual, for a well-known purpose, and the presser-foot, when in use, projects down into the slots or between the forks of the clamp, so as to admit of the usual feed being given the fabric when it is not held by the clamp, and without obstruction or impediment from the clamp.

The fulcrum-pivot e of the clamp-lever is shown as composed of a shouldered stud, the large or shouldered end of which plays beneath a plate or cover, E^1 , over the supplementary feed mechanism. The pivot works above its shouldered base in a longitudinal slot, e^1 , in this cover-plate, and is reduced in size, made round, and provided with a screw-thread at top to receive a nut, e^2 , by which to clamp the lever in place. An anti-friction washer is interposed between the under side of the lever and the cover-plate.

A roller, E^2 , is secured upon and freely revolves about a stud or pendent post at the heel end of the clamp-lever. The cover-plate is slotted for this roller to pass through and move freely as it is acted upon by the feeding devices.

In one way of adapting my improvements to the machine, as in this instance illustrated by the drawings, the metallic bed-plate or base of the frame is recessed or cut out to form a larger opening in its middle and depressed portion. A supplemental frame, plate, or casting, F , provided with a suitable opening extending nearly across it, and for the greater portion of its length, is attached upon the top of the bed-plate or base of the frame. This supplemental frame or plate F fits at its front end against the sewing-machine-frame shoulder formed by the rear end of the work-supporting portion or slightly-elevated part F' of the frame, and is of such a thickness as to bring its top surface about flush with or on the same level as the top surface of said elevated front portion F' of the machine. The cover E^1 is screwed down upon this plate F , and the plate itself suitably fastened in place on the frame.

Brackets or inwardly-projecting arms $f f^1$ —

in this instance cast with the supplementary frame or plate F upon its under side—are provided with fixed upright posts or stud-shafts, $f^2 f^2$, about which the clamp-lever operating and controlling devices revolve.

Upon the posts $f^2 f^2$ are mounted cam-wheels or pattern-disks $G G'$, one upon each post. One of these cams slightly overhangs or overlaps the other at its edge or periphery. The roller E^2 of the clamp-lever C' is engaged between and operated by the irregularly-shaped peripheries of the cams, which impart to the clamp a compound longitudinal and transverse movement, or irregular endwise reciprocation and vibratory movement. The movements imparted to the clamp may be greatly varied simply by altering the shape of the cams.

Each cam has detachably secured to its under side a gear-wheel or spur-pinion, H or H' , the pinion H being secured to and caused to revolve with the cam G by pins or short studs fitting in holes $g g$ in the cam, and the pinion H' correspondingly fitted to the cam G' by pins fitting the holes $g' g'$. These pinions are of corresponding size, and are fitted to the shafts f^2 so as to revolve freely, and motion is imparted to the cam G' through or by way of its pinion from the pinion H , thus causing the cams, when in motion, to revolve at the same rate of speed and in opposite directions, and act upon the roller E^2 so as to cause it to revolve upon its stud in the end of the lever C' , and avoid injurious frictional contact of the cams with the roller. The retracting and vibrating movements are imparted to the clamp by the cams. To cause the forward or endwise-thrust movement of the clamp $C D$, a spring is employed to keep the clamp always as far advanced as the cams will admit. The roller E^2 , it should be noticed, is behind the cams. An expansive spring, h , in a slot, h' , in the supplementary frame or removable plate F , bears upon the pivot e beneath the cover-plate E^1 , and acts with a tendency to thrust forward the clamp-lever C' , thus always keeping the roller E^2 in contact with the cams' peripheries, while readily yielding to admit of the proper action of the cams upon the clamp.

A "stop-motion" or intermittent movement is imparted to the cams, so that when thrown into operation they continue to act upon the clamp only until the figure, button-hole, &c., have been stitched.

In this instance motion is imparted to the cams and their revolutions stopped by the following means: A ratchet-wheel, I , is mounted upon the shaft f^2 beneath the pinion H , and is suitably connected with the pinion so as to revolve with it. A swinging stop-pawl or spring-detent, I' , prevents retrograde movement of the ratchet. This stop-pawl and its spring i are supported on the under side of the frame or bed of the machine. Upon the under side of the ratchet-wheel is a swinging

stop, J, pivoted at its heel to the ratchet inside of its teeth, and acted upon by a spring, J', the tendency of which is to throw the inclined shouldered end or nose *j* of the stop outward, so as to extend slightly beyond or outside of the ratchet-teeth. A pin, *i'*, on the ratchet, near its periphery, limits the outward movement of this spring-stop J, so that when its nose is pressed outward by the spring it does not, because of its shoulder or recess, interfere with the action of the detent or stop-pawl I'. The supplementary feed or attachment is actuated from the main driving-shaft of the machine in this instance by an endwise to-and-fro moving or reciprocating bar or plate, K, to which movement is imparted by the lower end B' of the vibrating needle-lever as it is swung back and forth by its cam.

This action of the needle-lever advances or thrusts forward the bar K, which is retracted or moved toward and held up to the lever end by a suitable spring, *k'*, fast at one end to the frame of the machine and at the other to the reciprocating bar. This spring is always under tension, and additional strain upon the bar is exerted by it as the bar is advanced, so that a quick retrograde movement of the bar is insured. A suitable guideway for the reciprocating bar is provided, shown by the drawings as formed by slots L L' in the bar working upon bolts or screws *l l'* in the frame-base. Washers are interposed between the screw-heads and the bar. A spring-pawl, M, to move the ratchet I tooth by tooth, is pivoted upon the reciprocating plate K at its heel. Its spring *m* acts with a tendency to throw in the pawl or move it toward the ratchet, so as to engage its teeth by its shouldered pointed nose, as will readily be understood by an inspection of the drawings.

To give a stop-motion or regularly-intermittent feed to the fabric-clamp operated by the cams, the spring *m* of the pawl M is weaker than the spring J' of the stop J. By this means, when the ratchet is set in motion and makes a complete revolution, the stop J, when brought again to the starting-point, is held out against its stop-pin *i'*, with its inclined outer end or edge of the nose *j* in position to have the pawl slide upon it, as it is constantly moved to and fro without engaging the ratchet. The force exerted by the spring J' must be sufficiently greater than that of the spring *m* to insure the intermittent movement of the cams. When the attachment is to be set in operation the spring J' is compressed and the stop J moved inward to enable the push-pawl M to act on the ratchet. After the ratchet is given a partial rotation by the first action of the pawl upon one of its teeth, the stop ceases to interfere with the intermittent or step-by-step rotation of the ratchet, pinions, and cams until again brought to the starting-point. The stop is moved inward and the power of its spring overcome by a tripping slide-bar or controlling thrust-arm, N, having a knob, N',

by which it is movable endwise in a suitable guide-slot in the frame of the machine. This slide is inclined at its end, and when thrust inward abuts against a shoulder, pin, or short stud, *n*, on the stop. A spring, O, normally holds this stop-tripping slide in its retracted position, and the slide is secured to the lower end of a stud or thumb-screw, O', passing through the frame-base and projecting above it in a position convenient to the operator who may, by moving the stud inward, set in motion the supplemental feed and the clamp when desired. This slide, it should be noticed, does not interfere with the operation of the ratchet-moving pawl, nor impede the starting movement of the ratchet.

I have herein described but one way of carrying out my invention and applying my improvements. The details of construction may be varied, and obviously some of the parts may be used without the others, and equivalent mechanism substituted for omitted parts. For instance, friction-clutch mechanism may be used in lieu of the pawl-and-ratchet stop-motion feeding devices. The cams may be changed so as to work an infinite variety of ornamental as well as other irregular figures, such as eyelets and button-holes of different sizes, &c., simply by the skill of the mechanic. To stitch button-holes, there is only required the simple change in the outline of the cams necessary to advance the clamp from one end to the other of the hole at one side, and simultaneously form the row of stitching by short transverse or vibratory movements of the clamp, then make longer vibratory movement, while the endwise movement of the clamp is intermitted, so as to cross-lock the end of the hole, then retreat or move inward, repeating the movement given on the advance, and finally cross-lock the finishing end of the hole and stop at the starting-point.

The operation of the attachment hereinbefore specifically described, and illustrated by the drawings, is as follows: The usual or regular row of stitching P, (see diagram, Fig. 7,) being made on a straight, curved, or irregular line, according to circumstances, by the usual operation of the machine until the point or place of the irregular or ornamental figuring is reached, the machine is stopped, the presser-foot raised, and the fabric clamped between the jaws or upper and lower sections, C D, of the clamp. The machine is again set in motion with the supplementary feed thrown into operation by the controlling-slide N, and the first ornamental figure, Q, worked during the intermission in the operation of the regular stitching and laterally to the stitched line P, and connected with it. After the completion of the figure—that is, when a complete revolution of the cams or pattern-wheels has been made—the supplemental feed is automatically thrown out of operation, as before explained. The machine is then stopped, the fabric removed from the clamp, the presser-foot low-

ered upon the goods, and the machine started, and the regular row of stitching resumed until the next figure, button-hole, &c., is reached, when the above-described operation of throwing into gear the supplementary feed and transferring the goods to the clamp attachment is repeated, and so on. If the regular row or connecting line of stitching is to be omitted, it is only necessary to keep the presser-foot elevated, move the goods the proper distance before clamping in the attachment, and cut off the waste thread between the successively-worked figures, &c.

This connecting line of stitching, however, in many instances, is highly advantageous, as by my method of intermittingly forming the row P of stitching and then working the figures I am enabled not only to increase the ornamental appearance of the goods, but also to unite two or more fabrics and work the figures either at regular or irregular intervals any desired distances apart by the intermittent operation of the needle and regular feed, and the needle, supplemental feed, and attachment—highly-desirable desiderata.

Upon first starting the attachment feed (see diagram, Fig. 7) the thread passes from the line P to or near the center of the figure Q, which is due to the fact that, as those portions of the cams marked 2 bear against and move in contact with the roller E² of the clamp-lever, this lever and the clamp are moved inward so as to present the fabric to the needle outside of and laterally to the stitched row P. When those portions of the adjacent edges of the cams marked 3 are acting upon the roller the clamp moves forward and laterally, thus bringing the needle nearer the line P and making the diagonal stitch 3 of the figure, and from this stitch the thread goes back to the center of the figure as the roller is acted upon by the portions 4 of the cams, and the clamp-lever retracted or moved inward. Those portions of the cams marked with even numbers, 2 to 16, both inclusive, when acting on the clamp-lever roller, present the fabric with the center of the figure to the needle, and those portions marked with odd numbers, 1 to 15, both inclusive, present the fabric to the needle, so that the star-like arms or stitches projecting in all directions from the center of the figure are formed.

These stitches, for convenience of illustration, are numbered correspondingly with the numbers on those parts of the cam-edges which impart the movements to the fabric necessary to the formation of the respective stitches. At the completion of a figure the cams cease to revolve with the clamp in the starting position and the goods in position relatively to the needle to resume the regular stitching connecting the figures, or to admit of the movement of the goods to the point at which the next figure is to be worked, without making the connecting row of stitches.

R is a diagram representing the movements given the roller of the cloth-clamp lever, and S a diagram illustrating the movements of the goods and clamp or end of the lever opposite to its roller. These diagrams will be understood by reference to the numbers on them and the corresponding numbers on the cams.

I claim as of my own invention—

1. The combination, in a sewing-machine, of a supplementary fabric-clamp and horizontally-rotating cams or pattern-wheels having irregular edges or peripheries, to impart to the clamp, by their simultaneous action, compound irregular endwise and vibratory movements, substantially as hereinbefore set forth.

2. The combination, in a sewing-machine, substantially as hereinbefore set forth, of a pivoted lever provided with the fabric-clamp and friction-roller, intermittingly-operating cams or pattern-wheels, and a spring by which to keep the lever in position to be operated by the cams.

3. The combination, substantially as hereinbefore set forth, of mechanism for forming the usual row of stitches, a supplementary clamp to hold the goods during the pauses in the formation of said row, the clamp-lever, its roller, cam-wheels acting at their edges upon said roller, and supplementary intermittingly-operating feeding devices, actuating the cam-wheels.

4. The combination, substantially as hereinbefore set forth, of the cloth-clamp, its lever acted upon by a spring, and provided with a roller, the cam-wheels, their gear-wheels, and intermittingly-operating mechanism, substantially such as described, actuated from the main driving-shaft, whereby the cams, when set in motion, make a single revolution to complete the working of a figure, and then pause.

5. The combination of the cams, their gear-wheels, the ratchet-wheel provided with the stop, the spring-pawl, the reciprocating plate upon which the pawl is secured, and the controlling-slide to start the supplementary feed, substantially as described.

6. The combination of the cams, their pinions, the ratchet-wheel provided with the stop, its detent, the reciprocating plate, its spring-pawl, the needle-lever, and the controlling-slide for starting the supplementary feed, these members being and operating, substantially as hereinbefore set forth.

7. The combination of the bed-plate or frame, the supplementary frame, its brackets, the bracket-shafts, the cams, and mechanism, substantially such as described, for operating the cams.

8. The combination of mechanism, substantially such as described, for forming the ordinary or connecting row of stitches, the supplementary cloth-clamp, and intermittingly-acting supplementary mechanism, substantially such as described, actuating said cloth-clamp when thrown into operation to work a single irregu-

lar or ornamental figure laterally to and connected with said ordinary row, and then stopping preparatory to the adjustment of the fabric for the continuation of the formation of the ordinary stitching, the combination being and operating substantially as described, whereby the figures may be worked at any desired distances apart, and each by a separate and distinct operation of the supplementary mechan-

ism thrown into operation by the operator, and regularly and positively intermitted, as set forth.

In testimony whereof I have hereunto subscribed my name.

JAMES ALFORD HOUSE.

Witnesses:

CHARLES H. DIMOND,
FRED. L. HEARSON.